

Tecnai on-line help manual -- User interface

Table of Contents

1	User Interface	5
1.1	View modes	6
1.2	Toolbar.....	6
1.3	Workset tabs.....	7
1.4	Control panels.....	7
1.5	Popup panels.....	9
1.6	Display.....	13
1.6.1	Binding display.....	13
1.6.2	Messages	15
1.6.3	Status displays.....	15
1.7	Help window.....	16
2	System settings and logging off.....	18
3	Windows controls.....	19
4	Control panels.....	22
4.1	Alignment procedures	23
4.2	Alignment deflectors.....	26
4.3	Alignment file	27
4.4	Alignments in the Tecnai microscope.....	29
4.5	Application Selection.....	30
4.6	Application Preferences	30
4.7	AutoFilter (User).....	31
4.7.1	EFTEM On.....	33
4.7.2	EFTEM On Plasmon	34
4.7.3	EFTEM Spectroscopy	35
4.8	AutoFilter (Expert).....	36
4.8.1	EFTEM On.....	37
4.8.2	EFTEM On Plasmon	39
4.8.3	EFTEM Spectroscopy	40
4.9	AutoFilter setup.....	41
4.9.1	AutoFilter Technique Options.....	41
4.9.2	AutoFilter View Options.....	42
4.9.3	AutoFilter Image Recording Options	42
4.9.4	AutoFilter Tune GIF Options	43
4.9.5	AutoFilter Energy Options	43
4.9.6	Filtered Imaging Setup.....	44
4.9.7	Elemental Mapping Preferences	44
4.9.8	Drift Measurement Preferences	44
4.9.9	Map Computation Preferences.....	45
4.9.10	Elemental Mapping Setup	45
4.9.11	Jump Ratio Mapping Setup	46
4.9.12	Spectroscopy Setup.....	46
4.10	AutoFilter Tuning (User)	47
4.10.1	Imaging.....	47
4.10.2	Spectroscopy	49
4.11	AutoFilter Tuning (Expert).....	50
4.11.1	Imaging.....	50
4.11.2	Spectroscopy	52
4.12	AutoFilter Tuning Restore.....	54

4.13	Beam Settings	55
4.14	CCD / TV Camera	57
4.15	CCD / TV Camera General	59
4.15.1	AnalySIS CCD	59
4.15.2	DigitalMicrograph CCD	60
4.15.3	TIA CCD	61
4.15.4	TIA Video	62
4.16	CCD / TV Camera Settings.....	63
4.17	CCD camera acquisition	64
4.17.1	CCD camera parameters	65
4.18	TV camera acquisition	67
4.19	Control Pad Lighting	69
4.20	Dark Field.....	70
4.20.1	Dynamic conical dark field.....	71
4.21	Detector Configuration.....	72
4.22	Detector Configuration Options.....	73
4.23	Direct alignments	75
4.24	EDX.....	76
4.25	EDX settings.....	77
4.26	Experiments	78
4.27	Spectrum acquisition	79
4.27.1	Multi-point spectrum acquisition	79
4.27.2	Spectrum-profile acquisition	80
4.27.3	Spectrum-image acquisition	81
4.27.4	Drift-corrected spectrum time series acquisition	82
4.27.5	Drift-corrected multi-point spectrum acquisition.....	83
4.27.6	Drift-corrected spectrum-profile acquisition	83
4.27.7	Drift-corrected spectrum-image acquisition	84
4.28	CCD diffraction-pattern acquisition	84
4.28.1	Multi-point CCD diffraction-pattern acquisition.....	85
4.28.2	CCD diffraction-pattern-profile acquisition	85
4.28.3	CCD diffraction-pattern-image acquisition	86
4.29	Experiments Settings.....	86
4.30	Experiments Loader	87
4.31	Filament (User).....	88
4.32	Filament (Expert)	90
4.33	Filament Settings (Expert)	92
4.34	Filament (Supervisor)	93
4.35	Filament Settings (Supervisor).....	95
4.36	High Tension (Expert/Supervisor).....	96
4.37	Image Settings	98
4.37.1	Image settings.....	98
4.37.2	Image shift	99
4.37.3	The image shift	101
4.38	Image Settings Focus.....	102
4.39	Measuring.....	103
4.39.1	Measuring in imaging	104
4.39.2	Measuring in diffraction	106
4.40	Multiple Exposure	108
4.41	Series	109
4.42	Double.....	110
4.43	Normalizations.....	111
4.43.1	Introduction to normalizations	111

4.44	PEELS.....	115
4.45	PEELS CCD.....	116
4.46	PEELS General.....	116
4.47	PEELS Settings.....	117
4.48	Plate Camera.....	119
4.48.1	Combining plate camera and CCD.....	119
4.49	Plate Camera Options.....	121
4.50	Plate Camera Settings.....	122
4.51	Plate Camera Stock.....	124
4.52	Stage ²	125
4.52.1	Positions.....	125
4.52.2	Tracks.....	126
4.52.3	Confirmation.....	126
4.52.4	Files.....	126
4.53	Stage ² Control.....	129
4.54	Stage ² File.....	131
4.55	Stage ² Set.....	132
4.56	Stage ² Settings.....	134
4.57	Stage.....	136
4.57.1	Specimen-stage Move To's and Go To's.....	137
4.58	Stage Control.....	137
4.59	Stage Enable.....	138
4.60	Stage File.....	138
4.61	Stage Set.....	139
4.62	STEM Imaging (User).....	141
4.63	STEM Imaging Focus (User).....	144
4.64	STEM Imaging Scan (User).....	144
4.65	STEM Imaging (Expert).....	146
4.66	STEM Imaging Focus (Expert).....	149
4.67	STEM Imaging Scan (Expert).....	150
4.68	STEM Detector (User).....	153
4.69	STEM Detector Selection (User).....	154
4.70	STEM Detector (Expert).....	155
4.71	STEM Detector Selection (Expert).....	156
4.72	STEM Detector Auto CB.....	157
4.73	Stigmator.....	158
4.74	Stigmator Popup.....	160
4.75	System status.....	161
4.76	Vacuum (User).....	163
4.77	Vacuum Cryo (User).....	165
4.78	Vacuum (Expert).....	168
4.79	Vacuum Cryo (Expert).....	170
4.80	Vacuum Settings (Expert).....	172
4.81	Vacuum (Supervisor).....	173
4.82	Vacuum Control (Supervisor).....	175
4.83	Vacuum Cryo (Supervisor).....	176
4.84	Vacuum Settings (Supervisor).....	178
4.85	Vacuum Overview.....	179
4.86	Vacuum Overview (TMP).....	182
4.87	Workspace layout.....	185
5	Control Pads.....	189
5.1	Left-hand Control Pad.....	189
5.2	Right-hand Control Pad.....	191

1 User Interface

The user interface consists of a number of separate elements. We can divide these into different categories:

- The **Main program**. This consists of the program title, menu bar and toolbar. It basically is a shell that allows the user to define the where, what and how of the other user interface elements. The user interface provides a number of fixed layouts (view modes) with rapid switching between them.
- The **Control panels**. These are sets of controls that belong together and that are displayed in a fixed window (normally one of three displayed on the left-hand side of the screen). Control panels are grouped in worksets which can be selected via a tab at the top of the area with the Control panels.
- The **Information panels**. These consist of a set of windows displayed near the bottom of the screen. They contain binding, microscope status information and messages or questions from the microscope to the operator.

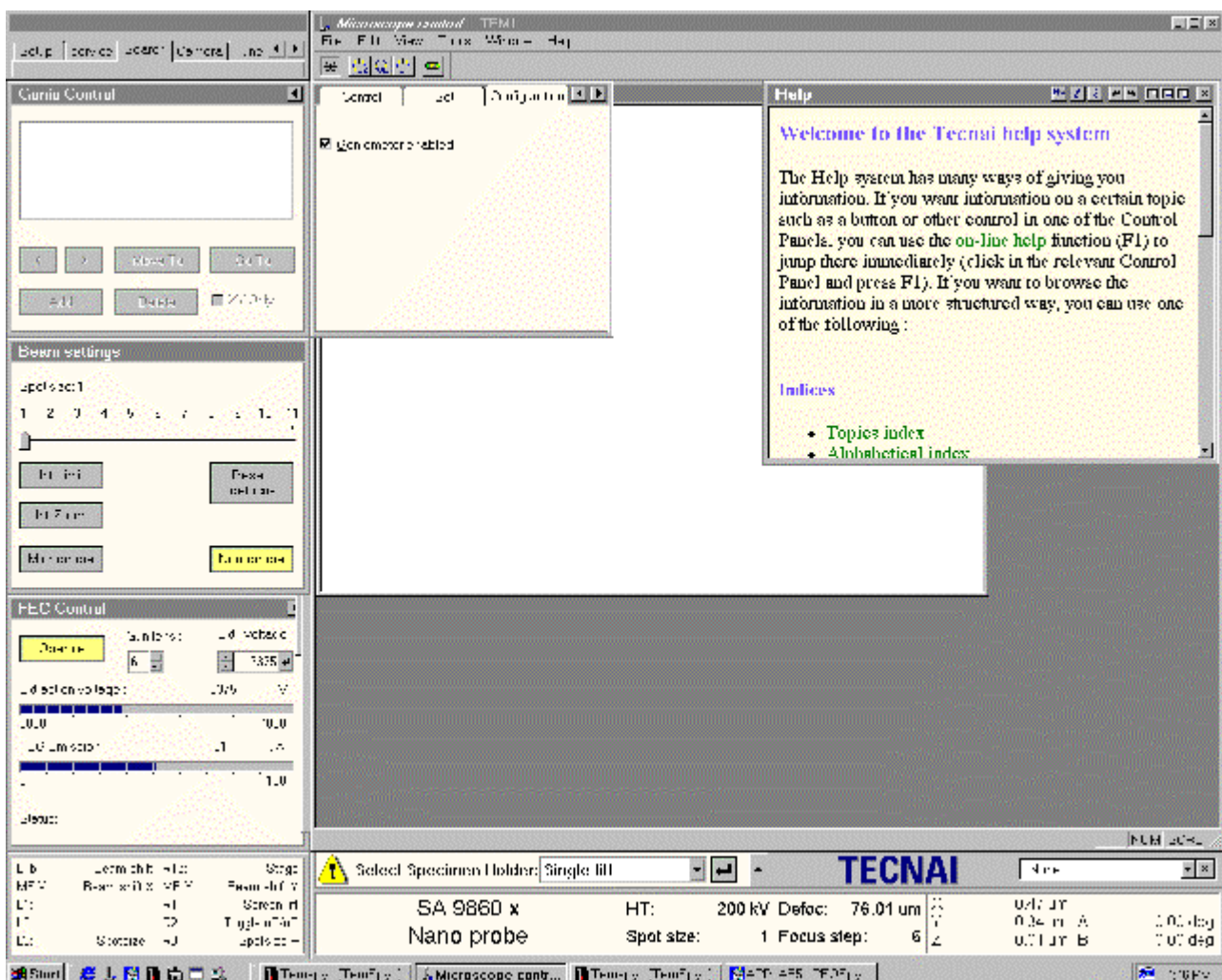

The empty area to the right is reserved for data like images, spectra, etc. Currently it shows the flap-out of the topmost Control panel as well as the minimum-size help window.

1.1 View modes

The microscope user interfaces supports a number of different viewing modes:

- Standard closed-frame view (data area filled by window in which a bitmap can be displayed).
- Standard open-frame view (data area left open).
- Minimum-size info area, closed (status display limited to column with Control panels, data area filled).
- Minimum-size info area, open (status display limited to column with Control panels, data area open).
- Taskbar only (user interface hidden except for a small band at the bottom).

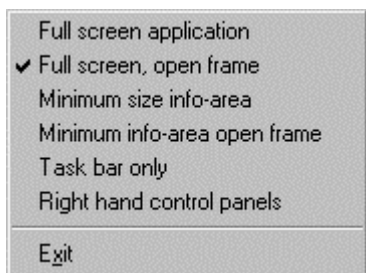

These different views make it possible to switch quickly between normal operation (standard open frame) and maximum space available for data display (minimum-size info or taskbar only). The views can be selected through the **Show** item of the menu or by clicking with the right-hand mouse button on a part of the information area that does not have any other right-hand mouse button menu (the message area is a good one, the binding display or status panels not). The following menu will popup on the right-hand click:

Note: To have the user interface start up by default in a certain view configuration (other than Standard open-frame), locate the shortcut (in the taskbar or Windows Explorer) from which the user interface is started, click on it with the right-hand mouse button and select Properties. After target you will see a reference to the real program (located in c:\tecnai\exe). Add one of the following to the line (separated by a space from what is there already):

- /p1 for standard closed frame
 - /p2 for standard open frame
 - /p3 for minimum info area closed
 - /p4 for minimum info area open
 - /p5 for taskbar only
- Nothing is the same as the default selection.

A rapid way of switching between Full size open frame en Task bar only is provided by a button next to the list of popup panels.



The button with the square blue block (far left) brings up the Application Selection Control Panel, while button with the L shape switches to Full size open frame mode.



The button with the square blue block (far left) brings up the Application Selection Control Panel, while button with the _ shape switches to Task bar only mode.

1.2 Toolbar

The user-configurable toolbar contains a number of icons that provide quick access to microscope functionality. To change the toolbar, select Tools, Customize from the menu. A dialog will appear. Select the Commands tab. You can drag any toolbar button present out of the toolbar to remove it. Select one of the items in the list (types of commands). Toolbar buttons belonging to that item will appear to the right. Click on any of the buttons and drag it into the toolbar. Drag a toolbar button slightly to the right to create a small space between it and the previous item. Close the dialog once done (OK) and the toolbar buttons for the user interface have been defined. Henceforth, the same toolbar selection will appear when you restart the user interface.

Some (currently implemented) useful buttons:



Under Stigmator the four buttons give shortcuts to None, Condenser, Objective and Diffraction.



Under Control pads the icons give quick access to background lighting and various LED intensities.

1.3 Workset tabs

At the top left of the user interface is a small window containing a (user-defined) number of tabs. Each of these tabs controls access to a number of Control panels (typically a set of three). Click on any of the of tabs to access it workset. Workset configuration (contents, name, order, color selection) can be default or as defined by the user.

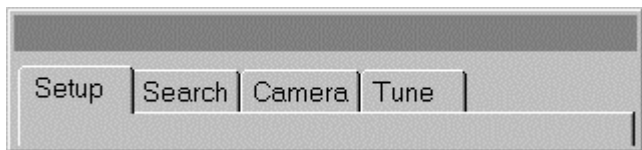

Worksets are intended to be arranged in sets that reflect a certain stage of operation of the microscope (but of course you are free to arrange them in any manner that you find suitable for the work you do). Thus the Setup workset could contain those controls needed when starting a microscope session (vacuum, high tension and filament control). The Search workset provides controls that are useful when searching around the specimen for areas suitable for further investigation (the Stage control panel, for example, allows storing and recall of specimen-stage positions). The Camera workset provides access to plate camera functions that allow recording of data like images and diffraction pattern during the more detailed investigations.

Control-panel access is also possible through the popup-panel selection (in that case the current selection remains on the left-hand side and the selected Control panel appears at the bottom right). Most control panels can only be selected for popup when they are already somewhere located in a tab.

Modifying the worksets

The worksets are defined using the Workspace Control Panel (because of its size accessible only in the popup selection).

1.4 Control panels

Control panels are small windows, typically arranged in sets of three above one another on the left-hand side of the screen (some Control panels are double-height and can therefore only be combined with one additional panel). Each Control panel contains a coherent set of microscope controls (like vacuum system, electron gun or stigmators). The combination of up to three Control panels forms a workset, defined by name and accessible through a tab in the workset selection window above the Control panels themselves.

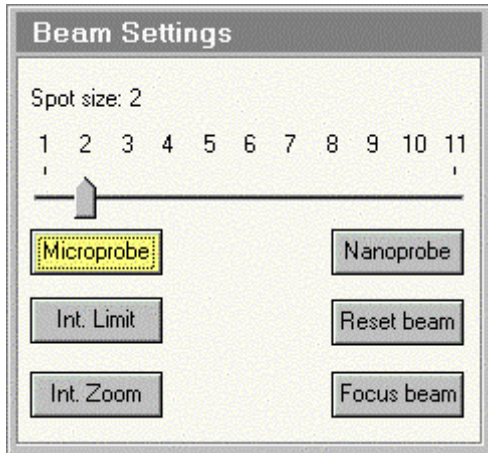

The Beam settings Control panel.

The rationale behind the Control panels is very simple. They are meant to give rapid access to elementary (often-used) microscope functionality. Selection of microscope settings (used much less often) is not accessible through the Control panels themselves but is 'hidden' away conveniently in flap-outs.

Panel flap-out

Some Control panels (like the Beam Settings Control panel) are simple and have no 'hidden' settings. Other panels are equipped with so-called flap-outs: additional panels that appear to the right of the main panel. Panels with flap-outs are recognizable by the flap-out arrow button at their top right.

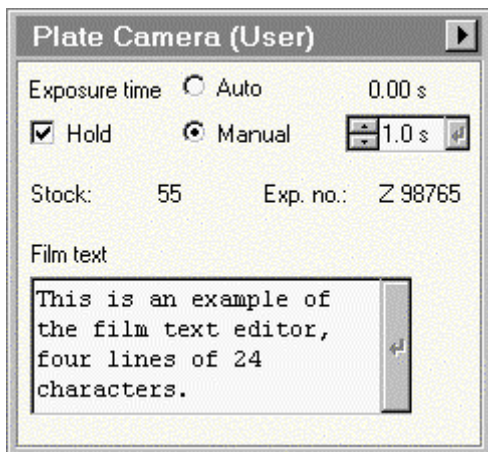

The Plate camera Control panel with the flap-out button (arrow pointing to the right at top right).

When the flap-out button is pressed, the flap-out panel appears. This panel has one or more panels itself, combined through the use of tabs. Click on a tab to access that particular panel. If the total series of tabs doesn't fit in the panel, left-right arrow buttons at top right allow shifting of the whole series of tabs to left or right.

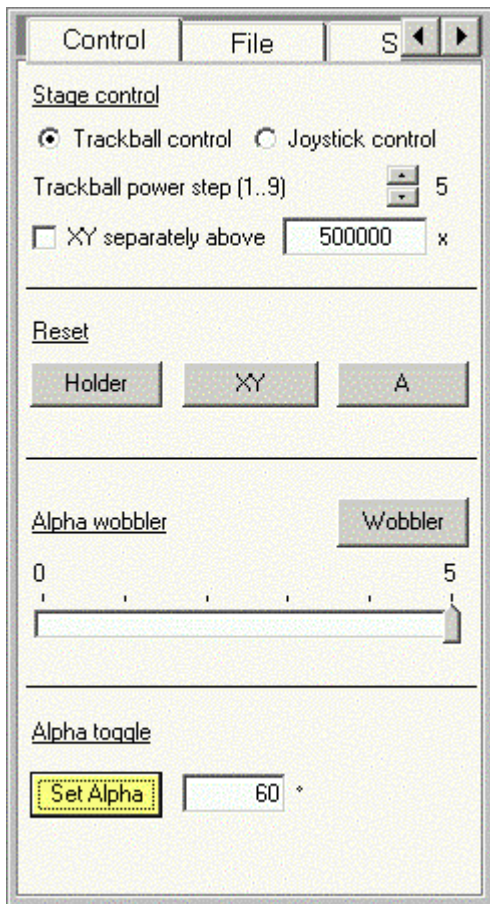

The Control tab of the Stage² Control panel flap-out.

Flap-outs remain visible until they are closed again (with the flap-out button which has reversed its pointing direction). They disappear from view when another workset is chosen but will reappear when the workset with the 'flapped-out' Control panel is chosen again.

On-line Help

Each Control panel has its own on-line help, accessible by clicking somewhere inside the Control panel, and then pressing F1. The Alignments Control panel and Direct Alignments Control Panel additionally have on-line help pages for each of the alignment subprocedures or direct alignments.

1.5 Popup panels

At the bottom right-hand side of the screen (right next to the microscope name) is a drop-down list box with a small 'x' button next to it (in other views than the standard frame it may be located elsewhere on the screen).



The drop-down list gives access to Control panels that will be displayed in the corner just above the list box itself. The selection of these 'popup' panels includes a number of Control panels that cannot be assigned to worksets (because of their size). The selection also includes those Control panels that are not currently visible on the screen. This means, for example, that you can have the microscope display the Plate camera control panel to have rapid access to the plate-camera settings, without changing from the current workset tab. As soon as the workset tab is changed to one containing the panel visible as a popup, the popup panel will disappear.

The popup is hidden again when:

- the small 'x' button is pressed.
- - None - is selected in the popup.
- the currently visible Control panel is already present in the workset tab being selected.

Special popup panels

Three popup Control panels are worth mentioning here since they can only be accessed in the popup because they are too large to fit inside the space normally reserved in the worksets for Control panels: the Vacuum overview, the Workspace lay-out and the System Status. The on-line help for these panels is once again accessible by clicking in them and pressing F1.

The Vacuum Overview Control Panel displays a graphical overview of the current status of the vacuum system.

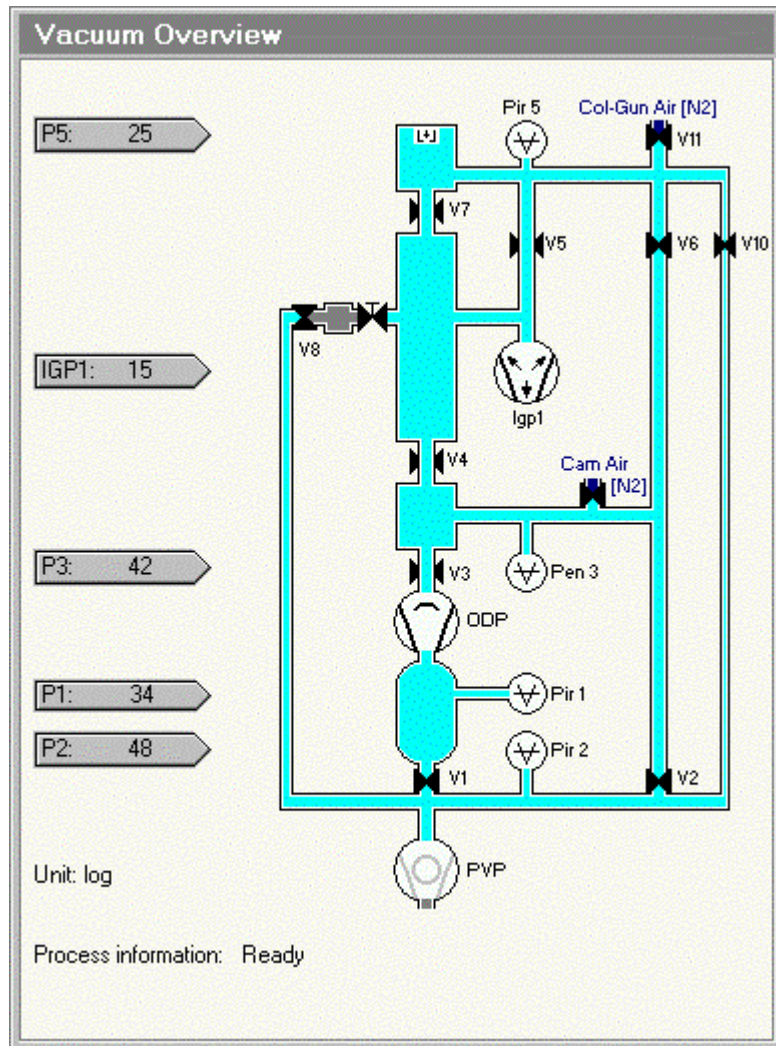

The Vacuum Overview Control Panel.

The Workspace Lay-out Control Panel provides the tools for customizing the worksets: Control-panel selection, color selection, etc.

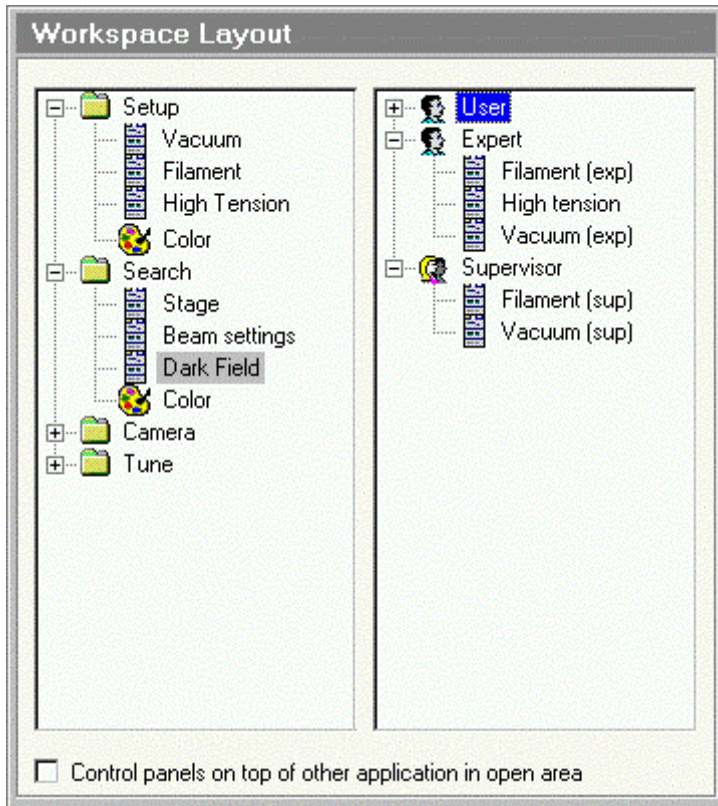

The Workspace Layout Control Panel.

The System Status Control Panel provides an overview of the (software) settings of all lenses and deflection coils.

System Status						
Measure currents		<input checked="" type="radio"/> Continuously		<input type="radio"/> One loop		
Lens						
Spot size	21.58 %					
Intensity	34.22 %					
Minicondenser	94.10 %					
Objective	6.00 %					
Diffraction	18.01 %					
Intermediate	0.00 %					
Projector 1	71.81 %					
Projector 2	64.00 %					
<hr/>						
Gun deflector	X	Y	Perp X	Perp Y	All	
Gun tilt	0.0801	-0.0204			U-X	-0.1177
Gun shift	0.0200	-0.0540			U-Y	0.0745
Spot-dep. shift	0.0176	-0.0001			L-X	-0.0011
Gun tilt pp	5.4830	5.4510	0.0000	0.0000	L-Y	-0.0449
Gun shift pp	4.0000	4.0000				
Beam deflector	X	Y	Perp X	Perp Y	All	
DF tilt	0.0000	0.0000			U-X	0.0090
User shift	-0.0100	0.0130			U-Y	-0.0012
Rot Center	0.0010	-0.0118			L-X	-0.0012
Align shift	0.0000	0.0000			L-Y	-0.0061
Beam tilt pp	4.2600	4.2600	-0.0010	-0.0012		
Beam shift pp	4.8000	4.8000				
Image deflector	X	Y	Perp X	Perp Y	All	
Image-Beam shift	0.0000	0.0000				
User diff. shift	0.0000	0.0000			U-X	-0.1243
User image shift	0.0000	0.0000			U-Y	-0.0014
Align diff. shift	-0.0020	0.0090			L-X	0.1494
Align image shift	0.1200	-0.0080			L-Y	-0.0061
Diff. shift pp	4.6890	4.6930	0.0010	0.0020		
Image shift pp	3.8420	3.8500				
Magn. corr.	0.0300	-0.0010				
Det. alignment	0.0000	0.0000				
X-over corr.	0.0000	0.0000				

The System Status Control Panel.

1.6 Display

The microscope user interface provides a series of panels containing microscope status information. These cover the binding display, message area and microscope status display.

1.6.1 Binding display

The binding display panel shows how the user-assignable knobs and buttons on the left-hand and right-hand Control Pads are linked to microscope functions. These knobs and buttons are:

- Left-hand track ball (typically assigned to beam shift)
- Right-hand track ball (typically assigned to CompuStage X and Y)
- Multifunction X
- Multifunction Y
- User button L1
- User button L2
- User button L3
- User button R1
- User button R2
- User button R3

The selection of the assignments displayed is up to the user. A typical selection could be displaying two columns:

LTb:	Beam shift	RTb:	Stage
MF X:	Beam shift X	MF Y:	Beam shift Y
L1:		R1:	Screen lift
L2:		R2:	Toggle uP/nP
L3:	Spotsize -	R3:	Spotsize +

Depending on the number of items present, the display will contain one (with subcolumns for knobs/buttons; their functions) or two columns (2x knobs/buttons; their functions). Empty lines can be used to give a balanced display selection.



Adding items

Click with the right-hand mouse button on a part of the binding display panel that holds the names of knobs and buttons (the far left or the left-hand side of the second column). A popup menu will appear.

Click on the item required and it will be added to the current selection. The All worksets item can either be checked (in which case the selection displayed is the same for all worksets) or not (in which case each workset can have its own selection). Note that the actual knob or button functionality selected is not dependent on the workset (only what is displayed).

Removing items

Click on the desired item and drag it out of the binding display panel.

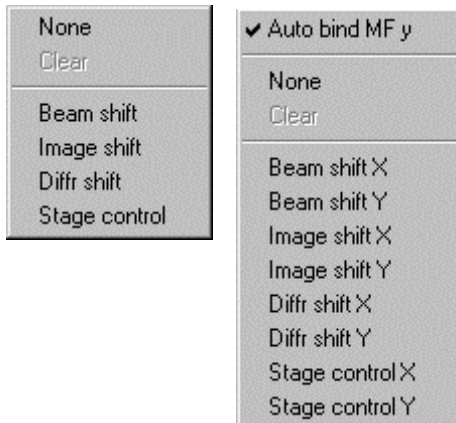

Changing a function assignment

Click with the right-hand mouse button on a part of the binding display panel that holds the function description for the knob or button required (the right-hand side of the first column or the far right). A popup menu will appear, whose content will depend on the type of knob/button selected (track ball, multifunction knob, user button). In the case of the Multifunction knobs, near the top of the popup menu is an item Auto bind MF y (when the MF-X selection is clicked) that, when checked makes the Multifunction knobs follow each other (that is, when the Multifunction knob X is given to the x parameter of a function, then Multifunction Y will automatically assume the y parameter of that function).

Multifunction knob assignments

The Multifunction knobs have a wide range of functions. All functions (wobbler, stigmators, dark field, alignment, etc.) that assign functionality to the multifunction knobs also release that functionality when the particular function is switched off again (after which the multifunction knobs regain their previous functionality). The functions are typically assigned whenever needed (e.g. during alignment). The user can also assign functions to the knobs (these functions will be overruled when necessary). There are two possibilities:

- The assignment is **persistent** (these functions will be overruled when necessary but the function is always returned when automatic assignments are taken off).
- The assignment is **temporary** (these functions will also be overruled when necessary and the function is not returned when automatic assignments are taken off).

A persistent assignment can only be made when the Multifunction knobs are not currently occupied by an automatic assignment, otherwise the assignment is temporary.

Examples

- The Multifunction knobs are currently assigned to the Stage axes (a user assignment). The user clicks with the right-hand mouse on the Binding display panel and chooses another function. This assignment is persistent.
- The Multifunction knobs are currently assigned to the Wobbler (after the Wobbler button has been pressed). The user clicks with the right-hand mouse button on the Binding display panel and chooses another function. This assignment is temporary (comes on top of the automatic Wobbler assignment) and will disappear when the Wobbler is switched off.

The None and Clear functions

The popup menu that allows setting of the binding configuration can have two functions, None and Clear. None is always enabled, Clear only when the current assignment is temporary. If None is selected, all functions are removed, independent of the nature of the current assignment (persistent, temporary or automatic). If Clear is selected (thus only possible if the assignment is temporary), the knob or button reverts to its prior automatic setting. Thus if you assigned the Beam shift function to the Multifunction knobs in an alignment procedure and then select None, the Multifunction knobs are completely cleared of all functions. Whereas if you used clear, the Multifunction knobs get back their setting from the alignment procedure.

Changing the relative position of items



Click on an item with the left-hand mouse button and drag it to a new position.

1.6.2 Messages





Messages by the microscope are shown in a dedicated part of the information area (above the status panel that typically contains the magnification and operating mode). Messages can have three different levels. Since only one message can be displayed at a time, important (higher level) messages will displace simple information messages.



The different levels are indicated by different icons:

-  Error
-  Warning
-  Information

If the message requires confirmation, it will stay displayed until the Enter button is pressed. Some other messages automatically disappear after a minute. All messages are kept in a list which becomes visible when the Up button on the right-hand side of the message area is pressed:

System	Description	Result	Time
 Stage	Select Specimen Holder:	Single Tilt selected	16:02:13
 Vacuum	column pressure too high.	Confirmed	16:01:35
 Vacuum	started.	Confirmed	16:01:11
 Log on	user MTD logged on.		15:51:02
 Stage	Select Specimen Holder:	No Specimen Holder ...	15:50:32

To close the list click the Up button (now changed to a down arrow) again.

1.6.3 Status displays

Up to three status display panels (in the minimum-size info area view this number is reduced to one). These status display panels can display a wide range of user-selectable microscope settings.

SA 97000 x TEM Bright field	HT: 190 kV Defoc: -13.00 um Spot size: 3 Focus step: 5
--------------------------------	------------------------------------------------------------------------------------

The left-most typically will display the microscope magnification and mode. This panel is also the one displayed in the minimum-size info area view. The two others are up to the user (by default they will contain the settings shown at the right of the picture above, while the third panel will display the specimen-stage position). All settings can be changed by the user.

Note: The magnification/camera length displayed depends on the position of the viewing screen. If the viewing screen is raised, the magnification/camera length values are those of the plate camera. If the viewing screen is down, the values are those as seen on the viewing screen.

Removing settings from status panels

Click on a setting in the status panel and drag it outside the panel.



Adding settings to status panels

Click with the right-hand mouse button on the status panel in the position where a new settings must be added. A popup menu will appear:

At the top of the menu (All worksets) the user selects (by checking or unchecking the item) whether the configuration as currently displayed is valid for all worksets (checked) or whether each workset can have its own settings. The other selections in the popup menu enter the required value into the status panel (in some cases one has to select via a submenu - move to the right where the small, right-pointing arrows are displayed). Empty lines can be added to give a balanced display. The font size will be adjusted automatically to the amount of space available.

1.7 Help window

The Help window, used for displaying the on-line help, is displayed in the area reserved for data (the empty area in the user interface). When F1 is pressed in the Tecnai user interface the help window becomes visible near the top left of the screen. Four views of different sizes are selectable through small buttons at the top of the Help window.

Note: The content of the Help window depends on the position of the cursor (if the cursor is over a main control panel, the help page of the main panel is shown; if it is over a flap-out panel, the you get the help of that panel - even if the original click with the left-hand mouse button was in the main panel). For proper operation of the help system, do not move the cursor out of the area for which help is requested until F1 has been pressed.

How does on-line help work?

The on-line help system consists of a series of html (Hypertext Mark-up Language: Internet browser) files. The contents of these files are displayed in the on-line help window of the Tecnai user interface. (But they can equally well be 'browsed' off-line using an Internet browser. The entry point is a file called Index.htm.)

In order to minimize the number of pages involved, many topics are arranged together with related topics on a single page. To allow rapid selection of relevant topics on such pages, they have been equipped with bookmarks (hyperlinks to the topics further down the page). The hyperlinks are clearly recognizable as such in the case of text (the unused hyperlinks are green, the used ones take the default color of the browser). It may also happen that hyperlinks are present on images, for example of control panels. Move the cursor over the image and hyperlinks will show up by the changing of the cursor to a hand.

For each topic lower on the page there is an up button: ▲ When the Up button is pressed, the page jumps back to the top. Technically speaking the Up button is again a hyperlink to a bookmark, but it doesn't show a hyperlink border.

The Help window can have three different formats, small, long and full. The 'small' help window covers a 1/4 area at top right. The 'long' window covers the vertical 1/2 area either on the left or on the right. The 'full' window covers the data window.

The window sizes (as well as some other functions) are controlled with the buttons that are present in the window title bar.



From left to right these buttons are:

- Load alphabetical index (a..z)
- Load topics index (t)
- Load main page (i)
- Back
- Forward
- Small help window
- Full help window
- Long help window on the left
- Long help window on the right
- Close help window

Back and forward work like in a normal Internet browser.

2 System settings and logging off

When you log off from the microscope (close the Tecnai User Interface) you will be asked if you wish to save system settings or not. What are these 'system settings'? They are not the changes you have made to the Tecnai User Interface layout like the selection of control panels and their arrangement over the tabs and the color selections made in Workspace Layout. Those changes are saved immediately as you make them.

What is saved under system settings is the following:

Column

- Operational settings (modes, spotsize, intensity,...)
- Normalization settings

Note: In order to get the microscope at log on always to an easily usable state, the microscope will always switch out of Dark field, STEM and EFTEM when logging on, even if that was the state the microscope was in while logging off.

Detectors

- Detector selection
- Contrast, brightness and filter settings per detector
- STEM acquisition settings
- EDX acquisition settings
- PEELS acquisition settings
- CCD acquisition settings

Knobs

- User settings on L1..L3, R1..R3
- User settings on the Multifunction knobs
- User settings on the trackballs

Plate camera

- um marker state
- Exposure number
- Plate label date type
- User code
- Exposure time type selection and hold
- Film types and settings
- Link to HT
- User stock value
- Exposure stock (system-wide)
- Selected film type (system-wide)
- For supervisor exposure number lock

Vacuum

- Vacuum display units
- Airlock time
- For supervisor the visibility of the Camera Air button

3 Windows controls

The user interface of the Tecnai microscope contain a number of Windows control elements like buttons, etc. For those unfamiliar with the terminology, these controls are listed below.

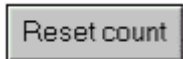

Button

Press it to have the program to something. If the function cannot be done under the current conditions, the button is greyed.

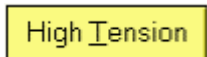

Three-state button

In addition to the normal and greyed states, this button has a yellow state which indicates that the function is on.

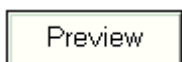

Four-state button

In addition to the normal and greyed states, this button has a white state which indicates that the selection is on and a yellow state which indicates that the selection is on and the function is active.



Label

Simple text in a window. Display only.

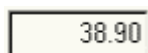

Edit

Allows insertion of text or numbers. Only used if there is some other way of having the program act on the change.



Check box

Selects (a cross is displayed in the square) or deselects a particular option. It also works when you click on the caption of the check box (so not only when you click inside the box itself).

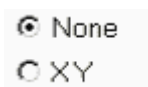

Radio buttons

Makes a selection from a series of mutually exclusive options. Clicking an unchecked option, checks that options and unchecks all others. Also works when you click on the caption of a radio button (so not only when you click on the circle itself).



Drop-down list

A list of items from which a selection can be made. In order to save space, the whole list only becomes visible when the arrow on the right is clicked. If text or a value can be entered at the top line, it is called a drop-down combo box.



Spin buttons

Change a number up or down by clicking on the up or down buttons. The numbers will spin faster if you keep one of the buttons pressed instead of giving single clicks.



Enter button

Confirm changes by pressing the enter button (pressing the button on the keyboard does the same).

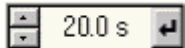

Spin-enter-edit

An edit control with spin buttons to change the value and an enter button to confirm the change (after which the program will act on it). The enter button indicates the status of the value. When the enter button is enabled, the value has been changed but not yet updated in the microscope (the update is done by pressing the enter button). When the enter button is disabled, the value indicated is the same as that on the microscope. When you use the spin buttons the value is directly transmitted to the server and the enter button will remain disabled. When you change the value by typing, the enter button will become enabled and you have to force the update by pressing the enter button.

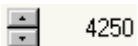

Spin-label

A control with an indicated value and spin buttons. Here the value can only be changed with the spin buttons.



Track bar

Drag the grey handle to another setting to change a value. You can also click to the left or right of the handle to make it jump one step.



Progress bar

Displays progress of a process or the current status as a fraction of the total range.

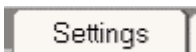

Tab

Allows selection of one of a series of displays.



Bitmap button

A button with a picture on it. These are used for the flap-out buttons, but also in toolbars, etc. They usually work the same as normal buttons, except that some toolbars buttons are flat (only show their outline when the cursor hovers above them) and can show an 'on' state by remaining 'pressed down'.

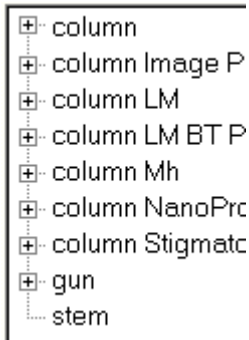

Treeview

Display a list of items, some of which (marked by a '+' sign) can be expanded to show their sub-items, and so on. Expansion happens when you click on the '+' (it will contract again when you click on the '-' sign that will take the place of the '+'). Alternatively you can expand by double-clicking on the caption (not double on the '+', that expand and contracts again). Select an item by clicking on the caption.

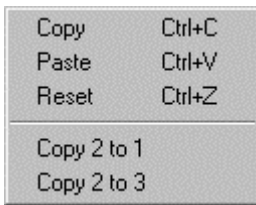

Popup menu

A single-column menu that becomes visible when the right-hand mouse button is clicked.

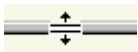

Splitter

A bar separating two areas in a window that allows changing the size of the two areas. The cursor show two lines drawn apart by two arrows.

4 Control panels

Note: The following Control Panels may not all available to all users on your microscope because:

- Some panels differ according to user level (User, Expert, Supervisor)
- The required hardware (STEM, Energy Filter) may not be present on the microscope.

The order in which the control panels are covered is alphabetically.

4.1 Alignment procedures

The alignment procedures of the Tecnai microscope are accessible through the Alignment control panel. The procedures, split into logical units such as Gun, Beam HM-TEM, Image HM-TEM, etc., are displayed in a treeview. Each procedure contains subprocedures that are accessible by clicking on the '+' in front of the procedure name (or double-clicking on the procedure name).

Alignments can be stored to file and wholly or in part restored to the microscope. Each alignment part corresponds to an alignment procedure (such as Gun, HM-Beam, HM-Image, etc.). Alignments for all users are located together and listed in the list of available alignments. The controls for saving and restoring alignments are found in the Alignment File Control Panel.

Note: Alignments saved under version 1.0 of the Tecnai software are not directly compatible with version 1.9 but can be reloaded into the microscope. Existing version 1.0 alignment files will be converted if the owner is the same as the current user. Non-converted alignments only provide a choice of Gun and Column (as in version 1.0), while converted or 1.9 version alignments have their selections split properly over the alignment procedures.

For more background information on how the microscope works with alignments, see Alignments in the Tecnai microscope (section 4.4).

A few rules:

- You do not change any alignments by walking through a procedure. Only when you change a setting in a step (usually with the Multifunction knobs, but in some cases also the Focus or Intensity) do you change alignments. Changes become operational immediately. They are stored when the alignment procedure is exited (Done).
- Start a procedure by clicking on the title of the first subprocedure (or the individual subprocedure required if not the whole procedure is needed). Stop a procedure by pressing Done, or Previous while in the first subprocedure step, or Next on the last subprocedure step. Going to another tab (where the Alignment Control Panel is no longer visible) also exits the alignment procedures.
- Navigation through a procedure is normally done with Next or Previous (the buttons on the control panel or R1 and L1 on the Control Pads). Using these buttons proceeds through the 'short' procedure, automatically skipping less-often used alignments (like pivot points). The skipped subprocedures can be accessed only by clicking on the title of the particular subprocedure. Navigation then may proceed to other, less-often used subprocedures. Subprocedures that are skipped are indicated by a different icon (blue arrow, on yellow, pointing down) and which are not (blue arrow, on white, pointing to the right).
- Each subprocedure can contain several steps (which are listed as '1 of 4' or '2 of 3'). You cannot go directly to a 'hidden' step because the first step sets the microscope in an appropriate condition for the alignment. In some cases first steps are skipped when using Next (because the previous subprocedure already put the microscope in the proper operating conditions so it doesn't need to be done again).
- Each (main) procedure is stand-alone in the sense that you cannot move automatically from one procedure to another by using Next or Previous, only with the mouse.
- Alignment procedures may differ depending on the level of user, with experts and supervisor levels having more alignments accessible than users.
- All subprocedures have on-line help pages that describe the purpose and operation of the particular alignment. Press F1 while a subprocedure is active and the proper page should come up. If another page comes up instead, the Alignment control panel was not the last window used. Click on the panel and press F1 again. When the Auto help check box is checked, the help pages are displayed and updated automatically.

- You can move to another control panel as long as you stay within the current tab (you can also pop-up panels on the lower right), but if you move to another tab, then the alignment is exited.
- In many the alignments steps the microscope is switched to specific magnifications, intensity settings, spot sizes, etc. There is however no protection against changes (sometimes a procedure step warns against staying within the current magnification range).

Note: The rotation center alignment is part of the 'Beam' procedures, not the 'Image' procedures (it is based on tilting the beam to the optical axis).

Tip: In some cases it may be useful to be able to see the settings of the most important lenses (C2, Obj, Diff). If the Alignments control panel is inserted in the user interface under a workset tab, define the status panel display (typically the one on the right) to have these settings listed.

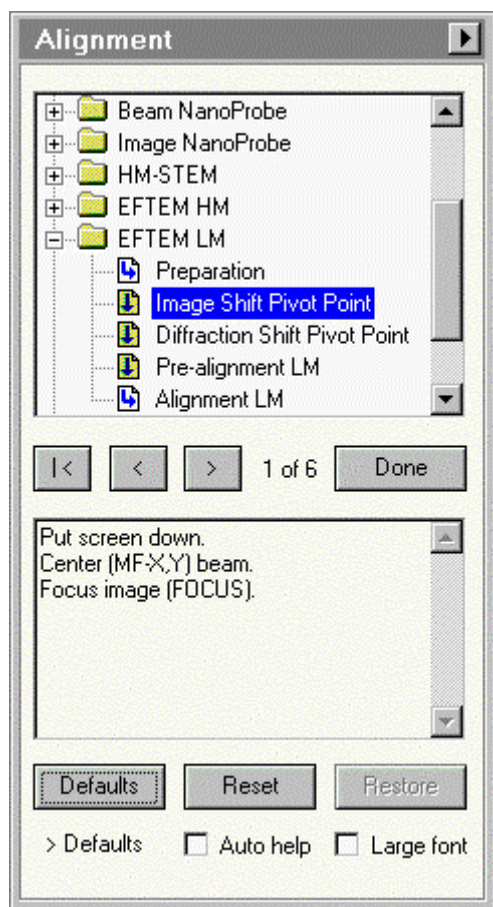

The Alignment Control Panel.

Procedure selection

Selection is done in the treeview that lists the procedures. Click on the '+' in front of the procedure name (or double-clicking on the procedure name). The treeview branch of the procedure will open and display the subprocedures. Click on the first subprocedure visible or any other subprocedure if only part of the alignment needs to be (re)done.

Subprocedures that follow the standard sequence (that is, they are not skipped) are designated by the icon with the blue arrow (on white) pointing to the right (into the subprocedure), whereas skipped subprocedures are designated by a blue arrow (on yellow) pointing down.

| <

Pressing the '|<' button moves to the first step of the alignment procedure (back to the very beginning).

<

Pressing the '<' (Previous) button steps one step back in the alignment procedure. If the current step is a first step of a subprocedure, the step always goes to the first step of the previous subprocedure (you cannot step backwards through one subprocedure to another). This button is equivalent to the L1 user button on the right-hand Control Pad.

>

Pressing the '>' (Next) button steps to the next step of the alignment procedure.

xx of yy

Indicates the current page of the subprocedure (xx) and the total number of pages (yy).

Done

Switches alignment off.

Procedure instructions

This field displays the instructions for the current alignment step.

Defaults

Pressing the defaults button resets the current alignment setting to that of the next higher level (depending on availability supervisor, service, factory, defaults). The level reverted to is indicated below the button (> Defaults in the example shown).

Reset

Pressing the Reset button resets the currently selected alignment to the setting it had when the step was entered. It allows you to undo any changes you made in the current step.

Restore

Pressing the Restore button resets the currently selected alignment to the setting it had before you pressed the Reset button. It allows you to undo the effect of a Reset.

Auto help

When the Auto help function is on, the on-help topic for the particular subprocedure is displayed automatically alongside (and also updated when a new subprocedure is started).

Large font

When the Large font option is checked, the instructions are displayed in a much larger (more easily readable) font (the downside is that the instruction will often not fit into the area available and the scrollbar on the right-hand side must be used to scroll the rest of the instructions into view).

Flap-out button

The flap-out button leads to the Alignment control panel flap-out containing the Deflectors and File control panels.

4.2 Alignment deflectors

The screenshot shows a software window titled 'Deflector' with a 'File' menu. It contains two sections: 'Beam Deflector (USER)' and 'Image Deflector (USER)'. Each section has several input fields with numerical values and units.

Beam Deflector (USER)	
BeamShift X:	82.3680 μm
BeamShift Y:	1.2642 μm
DF X:	29.161 mrad
DF Y:	4.254 mrad
DF Tilt:	29.470 mrad
DF Tilt:	0.291 nm
DF Rot.:	8.30 deg
Image Deflector (USER)	
ImageShift:	3.1814 μm
ImageShift X:	2.7210 μm
ImageShift Y:	1.6483 μm
Diffr. Shift X:	49.227 mrad
Diffr. Shift Y:	13.090 mrad
Diffr. Shift:	0.169 nm
Diffr. Rot.:	345.11 deg

The Alignment Deflectors Control Panel.

The Alignment Deflectors Control Panel displays the calibrated values of settings of various deflections used. These settings are adjusted when they are calibrated in the beam shift, beam tilt, image shift and diffraction shift calibration procedures.

Note: In order to have realistic and accurate values for beam shifts and tilts and for image and diffraction shifts (e.g. for measuring) it is important to calibrate these settings.

Beam shift

Beam shift values are listed in micrometers for X and Y.

DF (beam) tilt

Dark field (beam) tilt values are listed in various ways:

- Separate X and Y values (items #3 and #4 for the Beam Deflector).
- A total dark field tilt angle and a rotation angle (items #5 and #7).
- The d spacing corresponding to the total dark field tilt angle (item #6)

The d spacing is calculated from the dark field tilt angle and the high tension of the microscope. The high tension defines the electron wavelength, which allows conversion of an angle (in this case the dark field tilt) into a d spacing through Bragg's Law $2 \sin\theta = \lambda / d$.

Image shift

Image shift values are listed for the total shift (item #1 for the Image Deflector, having X and Y combined) and X and Y separately (items #2 and #3).

Diffraction shift

Diffraction shift values are listed in various ways:

- Separate X and Y values (Image Deflector items #3 and #4).
- The d spacing corresponding to the total dark field tilt angle (item #5).
- A diffraction shift rotation angle (item #6).

A shift of the diffraction pattern corresponds to a certain diffraction angle (for example, if you shift the pattern from the central, transmitted beam to a diffracted beam, you have shifted the pattern by the

Bragg angle of the diffracted beam). The d spacing corresponding to the diffraction angle is calculated from the diffraction shift angle and the high tension of the microscope. The high tension defines the electron wavelength, which allows conversion of an angle (in this case the diffraction shift) into a d spacing through Bragg's Law $2 \sin\theta = \lambda / d$.

4.3 Alignment file

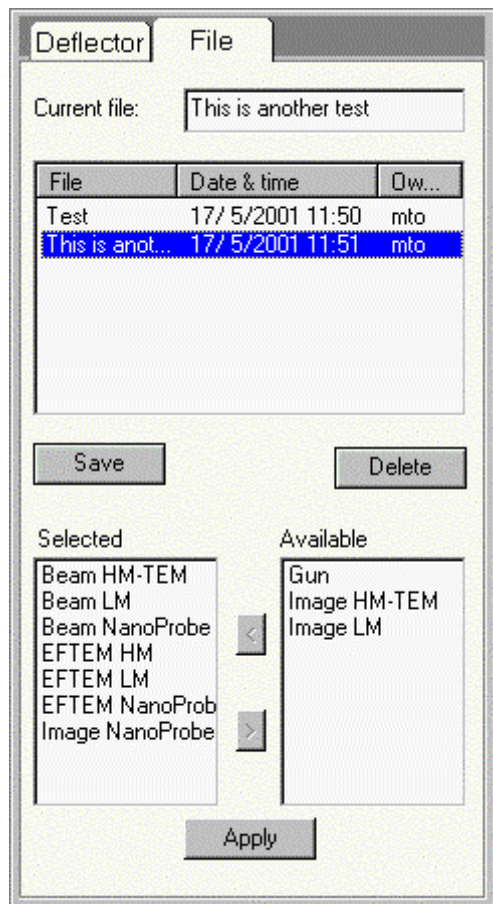

The Alignment File Control Panel.

The Alignment File Control Panel contains the controls for saving alignments to and loading them from file. Alignments can be stored to file and wholly or in part restored to the microscope. Each alignment part corresponds to an alignment procedure (such as Gun, HM-Beam, HM-Image, etc.). Alignments for all users are located together and listed in the list of available alignments.

Note: Alignments saved under version 1.0 of the Tecnai software are not directly compatible with version 1.9 but can be reloaded into the microscope. Existing version 1.0 alignment files will be converted if the owner is the same as the current user. Non-converted alignments only provide a choice of Gun and Column (as in version 1.0), while converted or 1.9 version alignments have their selections split properly over the alignment procedures.

There are a few simple rules concerning alignments:

- You can load any alignment present in the list.
- You can create any number of alignments yourself.
- You can delete your own alignments (and the supervisor can delete all alignment files).
- You cannot delete alignments from another user.
- You cannot overwrite alignments from another user (which would effectively be the same as deleting it and using the same name for your own alignment).

Current file

For creating a new alignment type a name in the edit control. The characters in the name must all be valid for filenames (so do not use characters like * / ? or \). If an alignment is selected in the file list, its name is automatically filled in under current file.

File list

The file list contains all available alignments. The alignments are listed with their name, their date and time of creation and the owner (creator of the alignment). Initially the list is sorted alphabetically on

alignment name, but the sorting order can be changed by clicking on the buttons above the columns (File, Date & time, Owner). Clicking the same button again reverses the sorting order.

The width of the columns of the list can be adjusted by clicking at the boundary between the buttons at the top of the columns (the cursor changes to a vertical bar with two arrows pointing sideways) and dragging it sideways.

Multiple entries can be selected (for deletion only, you can of course not reload multiple alignments) by clicking on more than one name with the Ctrl key on the keyboard pressed (each click selects - or deselects again - a single entry) or by first clicking one name and then clicking on another name with the Shift key (selects all entries between the two names at top and bottom as well).

Save

When the Save button is pressed an alignment is saved under the name defined. The Save button is only enabled when it is valid for the user to save an alignment (a valid name has been entered that is not the same as that of another alignment from a different user). If you are overwriting an existing alignment, you are asked for confirmation.

Delete

When the Delete button is pressed the alignment(s) selected is (are) deleted. Users (other than the supervisor) cannot delete other users' alignments so the Delete button is enabled only when the alignment(s) selected belong to you.

Selected list

When an alignment from the list is selected, the microscope compares the date of the alignment with the date for your current alignment. If elements (currently only Gun or Column) of the alignment stored are more recent than your alignment, those elements are inserted in the Selected list. If the stored alignments are older, they are inserted in the Available list on the right. Alignment elements can be moved from one list to the other with the < and > buttons. The elements in the Selected list are restored to the microscope when the Apply button is pressed.

Available list

When an alignment from the list is selected, the microscope compares the date of the alignment with the date for your current alignment. If elements (currently only Gun or Column) of the alignment stored are older than your alignment, those elements are inserted in the Available list. If the stored alignments are more recent, they are inserted in the Selected list on the left. Alignment elements can be moved from one list to the other with the < and > buttons. The elements in the Available list are not restored to the microscope when the Apply button is pressed.

< >

Alignment elements can be moved from the Selected to the Available list and vice versa. Click on an element in one of the lists (the element becomes highlighted) and press the < or > button (with the direction of movement indicated by the < and >). Only the elements in the Selected list are restored to the microscope.

Apply

When the Apply button is pressed, the alignment elements in the Selected list are restored to the microscope. If the Selected list is empty, the Apply button is disabled.

4.4 Alignments in the Tecnai microscope

When a user logs into the microscope (by starting the Tecnai user interface), the microscope will recall the necessary alignments. The microscope will follow a fixed procedure in restoring these alignments:

- Look if a particular alignment exists for the user and, if so, load it.
- If no user alignment exists, look if the alignment exists for the supervisor and, if so, load it.
- If no supervisor alignment exists, look if the alignments exists for service and, if so, load it.
- If no service alignment exists, look if the alignments exists for factory and, if so, load it.
- If no factory alignments exists, load default settings.

Alignments will exist for a particular user if the user has ever executed (part) of an alignment procedure. Alignments are as much as possible saved as a single parameter (except in the case of linked parameters like pivot points or x-y values which are always kept together). A complete alignment for a user may thus consist of a mix of user-aligned values and values from other levels (supervisor, ...). A user who has never done a gun alignment thus inherits the alignment from supervisor or higher. If the filament (on LaB6 or W) or FEG tip has been changed and a new alignment done by the higher level, the user will automatically get the new, correct alignment.

When alignments are stored in a file, they are stored completely (thus not only the user's own values). Upon restore the microscope will compare the values being reloaded. If the values are identical to the values in the next higher existing level, the values are not stored in the user's own alignments.

4.5 Application Selection

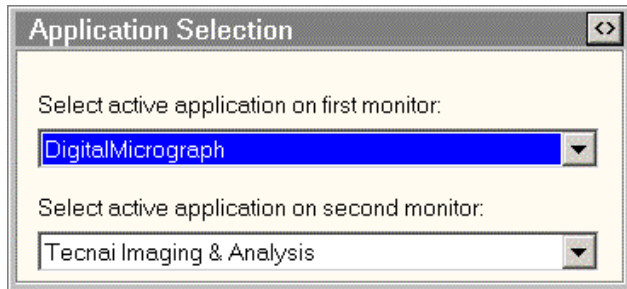

The Application Selection Control Panel provides the tools for adjusting applications to fill either the data space of the Tecnai User Interface or a second monitor. Choose the applications for the first and second monitor from the two drop-down lists.

The Application Selection Control Panel is brought up by clicking on the (left-most) "square" blue button in the popup selection panel (bottom right of the Tecnai User Interface).

The <> button (top right) switches to the Application Preferences Control Panel.

4.6 Application Preferences

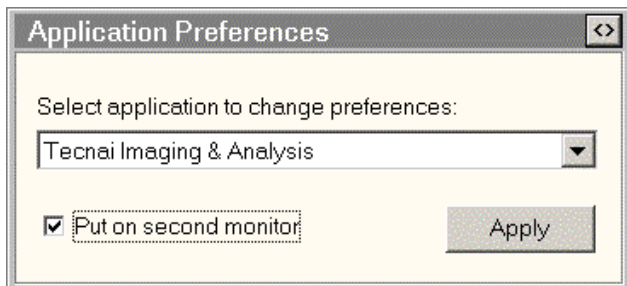

The Application Preferences Control Panel is used to determine where selected applications will be shown, in the data space of the Tecnai User Interface or on a second monitor.

Select an application from the drop-down list and change the setting of the check box Put on second monitor. Press Apply to activate the changed setting.

The <> button (top right) switches to the Application Selection Control Panel.

4.7 AutoFilter (User)

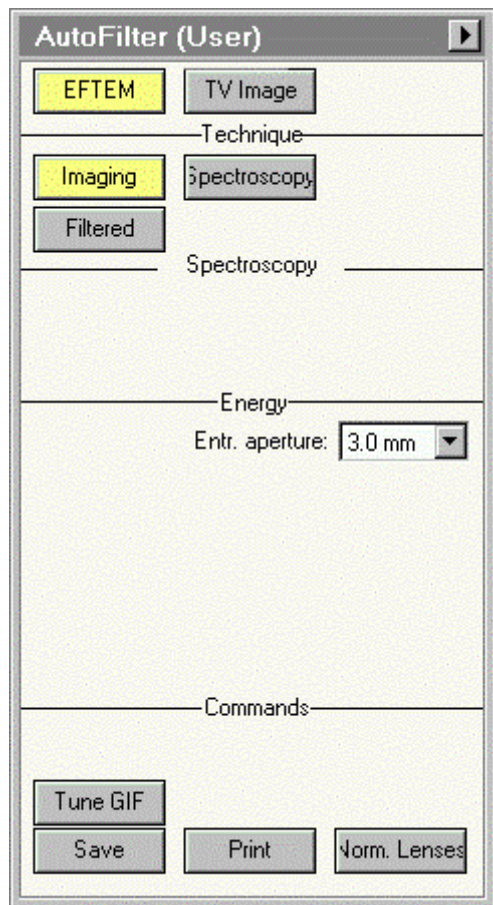

The AutoFilter control panel.

The AutoFilter control panel contains a number of controls for the Imaging Filter. The visibility of a number of buttons and other controls (under Energy and Commands) depends on the current state of EFTEM. For more background information on EFTEM, see the description of the Energy-Filtered TEM (EFTEM) mode.

EFTEM

The EFTEM button controls the microscope status:

- EFTEM off : the button will be gray, the screen will be down, and the magnification series will be the normal series
- EFTEM on : the button will be yellow, the screen will be up, and the magnification series will be the special EFTEM series

TV Image

The TV Image button toggles between Imaging Filter TV-rate camera inserted (button yellow) and retracted (button gray).

Imaging

When the Imaging button is pressed, the Imaging Filter switches to the imaging state (display of spectrum instead of image). To acquire the images on CCD, use the controls in the CCD/TV Camera control panel.

Spectroscopy

When the Spectroscopy button is pressed, the Imaging Filter switches to the spectroscopy state (slit out, display of spectrum instead of image). In order to prevent overloading of the CCD, the user interface will display a message "Please make sure you reduce beam intensity". This message must be confirmed (by pressing the enter button next to the message) before the system will switch to spectroscopy.

Filtered

When the Filtered button is pressed, the Imaging Filter switches between the filtered state (slit in) and unfiltered state (slit out).

Entrance aperture

The Imaging Filter has a number of entrance aperture. For imaging you typically use the 3 mm, aperture, for spectroscopy one of the smaller ones. Select the required entrance aperture from the drop-down list.

Tune GIF

When the Tune GIF button is pressed, the AutoFilter will start its tuning procedure, as defined under the AutoFilter Setup.

Save

When the Save button is pressed, the last Acquired image is saved to disk in the DigitalMicrograph Film stock folder (a folder called Film stock under the DigitalMicrograph folder) either under a generic file name or a user-specified name (dependent on the choice under the Action options).

Print

When the Print button is pressed the currently active image is printed (a default printer must be installed for this option to work).

Norm. lenses

Because of the settings of the lenses of the projection system, especially for the very low magnifications and camera lengths, the image/diffraction shift and cross-over corrections can be very sensitive to the accuracy with which the lenses are set. In order to make this more reliable, the normalization procedure is used. The automatic normalizations will normalize the lenses when the magnification or camera length is changed in EFTEM. In case the automatic normalizations for this mode are switched off, the normalization can be done by pressing the Norm. Lenses button.

Flap-out button

The flap-out button leads to the AutoFilter Setup Control Panel.

4.7.1 EFTEM On

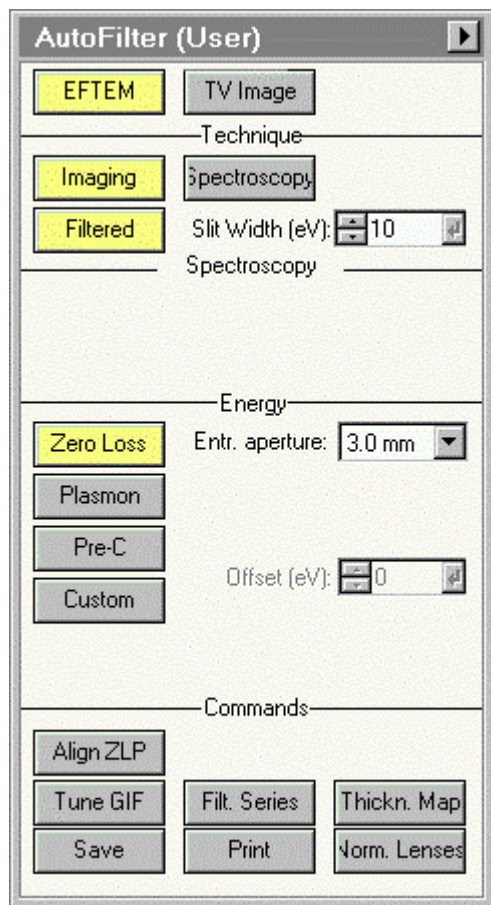

Slit width

The slit width control determines the width of the slit on the Imaging Filter.

Zero Loss

When the Zero Loss button is pressed, the Imaging Filter goes to Zero-Loss imaging (the zero-loss peak is centered in the energy slit). By definition the Energy Loss value is 0 so the energy offset control is disabled.

Plasmon

When the Plasmon button is pressed, the Imaging Filter goes to Plasmon imaging (the plasmon energy selected is centered in the energy slit). The accessible range of energies is subject to the choice in the DigitalMicrograph AutoFilter palette (with the Alt button pressed, click on the Plasmon, Pre-C or Custom buttons).

Pre-C

When the Pre-C button is pressed, the Imaging Filter goes to Pre-C imaging (the Pre-C - pre-carbon - energy selected is centered in the energy slit). The accessible range of energies is subject to the choice in the DigitalMicrograph AutoFilter palette (with the Alt button pressed, click on the Plasmon, Pre-C or Custom buttons).

Custom

When the Custom button is pressed, the Imaging Filter goes to Custom imaging (the custom energy selected is centered in the energy slit). The accessible range of energies is subject to the choice in the DigitalMicrograph AutoFilter palette (with the Alt button pressed, click on the Plasmon, Pre-C or Custom buttons).

Offset (eV)

With the Offset control, the value of the energy loss is chosen. The control panel keeps separate values for the three conditions in which the energy loss can be chosen: Plasmon, Pre-C and Custom. If you type the value, it must be activated by pressing the enter button.

Slit Width

With the Slit Width control, the width of the slit is chosen (in eV). The control panel keeps separate values for the four different conditions, Zero-Loss, Plasmon, Pre-C and Custom.

Align ZLP

When the Align ZLP button is pressed, the AutoFilter goes through its Align Zero Loss Peak routine, wherein it will attempt to center the zero-loss peak of the energy spectrum in the center of the slit. For proper operation of this function, the slit width should not be too small (at least 10 eV). If the zero-loss peak is only slightly misaligned, the procedure should work under all conditions, but if no previous filtered image has been obtained, make sure that the magnification selected is in the middle of the range

(~100 000x) and not too low (where the differential pumping aperture can partially block the beam so the Filter cannot find sufficient intensity).

Filtered Series

When the Filtr. Series button is pressed, the Imaging Filter will acquire a filtered series (a series of filtered images at specified starting energy and energy interval).

Thickness Map

When the Thickness Map button is pressed, the Imaging Filter will acquire two images, one filtered, the other unfiltered and from those calculate a thickness map (expressed in mean free path units).

4.7.2 EFTEM On Plasmon

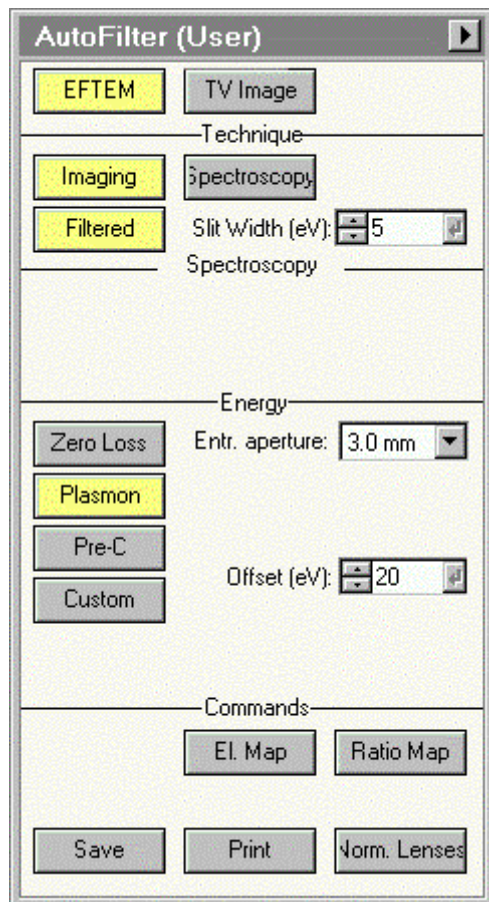

El. Map

When the El. Map button is pressed, the Imaging Filter Elemental Mapping procedure (three-window method) is started. The element settings are those chosen in the AutoFilter Setup.

Ratio Map

When the Ratio Map button is pressed, the Imaging Filter Ratio Mapping procedure (two-window method) is started. The element settings are those chosen in the AutoFilter Setup.

4.7.3 EFTEM Spectroscopy



Search, Preview, Acquire

Spectroscopy has three acquisition states which are independent from those of imaging : Search, Preview and Acquire. You can switch from one state to another or switch active acquisition on or off by pressing the Search, Preview and Acquire buttons.

Cumulative

Switches Cumulative acquisition on or off (in cumulative, spectra acquired are added together, otherwise each new spectrum replaces the one acquired previously). If Cumulative was off; the button will turn yellow or stops spectrum acquisition in the Cumulative state. If Cumulative was already on; the button will turn white.

Exposure time

The exposure time for the three spectrum acquisition states can be adjusted by selecting the state through the drop-down box and changing the value of the exposure time. If you type the value, it must be activated by pressing the enter button.

Dispersion (eV/pixel)

The dispersion in spectroscopy (the energy width per pixel) is selected via the drop-list box.

Align ZLP

The Align Zero-Loss Peak function in spectroscopy works different from that in imaging. In spectroscopy you use to set the scale of the EELS spectrum. Operation of the function is as follows:

- Acquire an EELS spectrum (continuous or single acquisition),
- Type in the value of the energy where the zero-loss peak is currently displayed under Energy shift and press the Enter button.
- Press the Align ZLP button.

The energy scale should now have 0 at the position of the zero-loss peak.

4.8 AutoFilter (Expert)

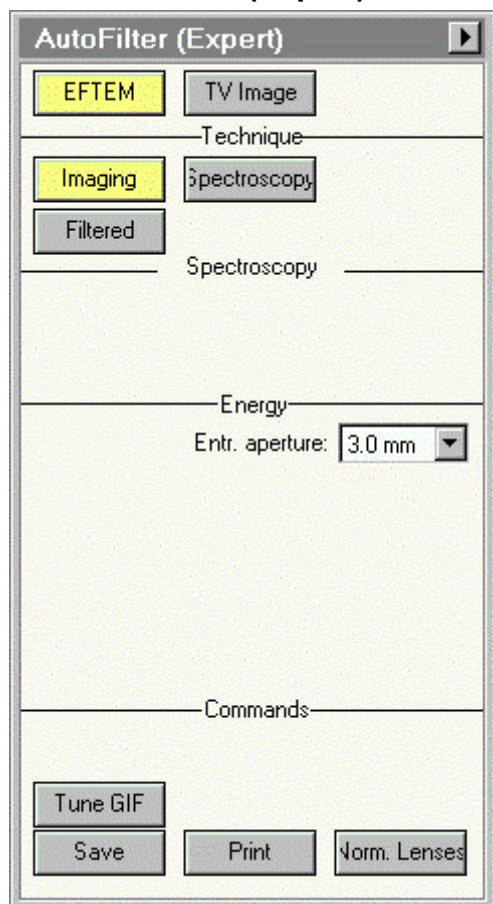

The AutoFilter control panel contains a number of controls for the Imaging Filter. The visibility of a number of buttons and other controls (under Energy and Commands) depends on the current state of EFTEM. For more background information on EFTEM, see the description of the Energy-Filtered TEM (EFTEM) mode.

EFTEM

The EFTEM button controls the microscope status:

- EFTEM off : the button will be gray, the screen will be down, and the magnification series will be the normal series
- EFTEM on : the button will be yellow, the screen will be up, and the magnification series will be the special EFTEM series

TV Image

The TV Image button toggles between Imaging Filter TV-rate camera inserted (button yellow) and retracted (button gray).

Imaging

When the Imaging button is pressed, the Imaging Filter switches to the imaging state (display of spectrum instead of image). To acquire the images on CCD, use the controls in the CCD/TV Camera control panel.

Spectroscopy

When the Spectroscopy button is pressed, the Imaging Filter switches to the spectroscopy state (slit out, display of spectrum instead of image). In order to prevent overloading of the CCD, the user interface will display a message "Please make sure you reduce beam intensity". This message must be confirmed (by pressing the enter button next to the message) before the system will switch to spectroscopy.

Filtered

When the Filtered button is pressed, the Imaging Filter switches between the filtered state (slit in) and unfiltered state (slit out).

Entrance aperture

The Imaging Filter has a number of entrance aperture. For imaging you typically use the 3 mm, aperture, for spectroscopy one of the smaller ones. Select the required entrance aperture from the drop-down list.

Tune GIF

When the Tune GIF button is pressed, the AutoFilter will start its tuning procedure, as defined under the AutoFilter Setup.

Save

When the Save button is pressed, the last Acquired image is saved to disk in the DigitalMicrograph Film stock folder (a folder called Film stock under the DigitalMicrograph folder) either under a generic file name or a user-specified name (dependent on the choice under the Action options).

Print

When the Print button is pressed the currently active image is printed (a default printer must be installed for this option to work).

Norm. lenses

Because of the settings of the lenses of the projection system, especially for the very low magnifications and camera lengths, the image/diffraction shift and cross-over corrections can be very sensitive to the accuracy with which the lenses are set. In order to make this more reliable, the normalization procedure is used. The automatic normalizations will normalize the lenses when the magnification or camera length is changed in EFTEM. In case the automatic normalizations for this mode are switched off, the normalization can be done by pressing the Norm. Lenses button.

Flap-out button

The flap-out button leads to the AutoFilter Setup Control Panel.

4.8.1 EFTEM On

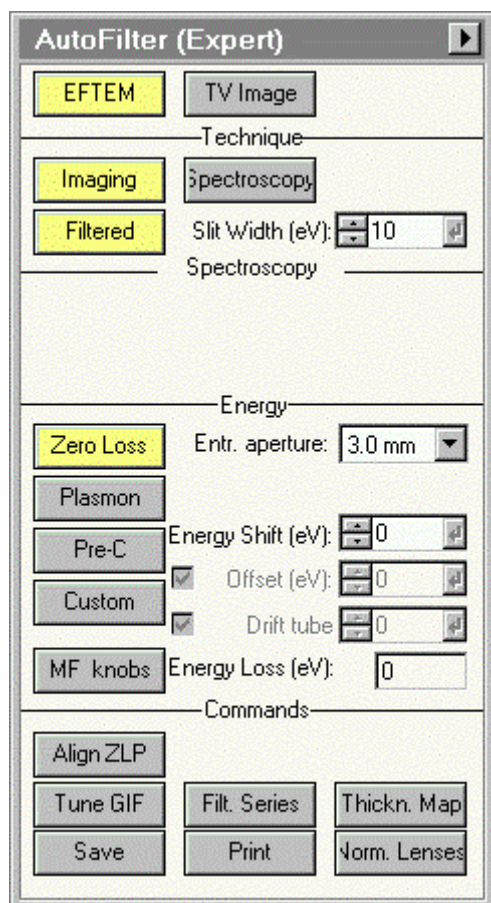

Slit width

The slit width control determines the width of the slit on the Imaging Filter.

Zero Loss

When the Zero Loss button is pressed, the Imaging Filter goes to Zero-Loss imaging (the zero-loss peak is centered in the energy slit). By definition the Energy Loss value is 0 so the energy offset control is disabled.

Plasmon

When the Plasmon button is pressed, the Imaging Filter goes to Plasmon imaging (the plasmon energy selected is centered in the energy slit). The accessible range of energies is subject to the choice in the DigitalMicrograph AutoFilter palette (with the Alt button pressed, click on the Plasmon, Pre-C or Custom buttons).

Pre-C

When the Pre-C button is pressed, the Imaging Filter goes to Pre-C imaging (the Pre-C - pre-carbon - energy selected is centered in the energy slit). The accessible range of energies is subject to the choice in the DigitalMicrograph AutoFilter palette (with the Alt button pressed, click on the Plasmon, Pre-C or Custom buttons).

Custom

When the Custom button is pressed, the Imaging Filter goes to Custom imaging (the custom energy selected is centered in the energy slit). The accessible range of energies is subject to the choice in the

DigitalMicrograph AutoFilter palette (with the Alt button pressed, click on the Plasmon, Pre-C or Custom buttons).

Energy shift, Offset, Drift tube, Energy Loss

On the Imaging Filter there are three ways to change the energy of the spectrum:

- With the current of the energy-loss prism in the Imaging Filter - called Energy shift.
- With the high tension of the microscope - called Offset.
- With the electrostatic drift tube of the Imaging Filter - called Drift tube.

The Energy Loss value given is the sum of all three values mentioned above.

Note: The convention used in the AutoFilter control panel is that positive values always indicate energy losses. Thus a value of 284eV on any of these controls always displaces to the carbon K edge. This usage differs from that in Gatan's FilterControl where the behavior is not consistent and therefore difficult to follow.

The Offset is normally used in Imaging because in that case when you look at another energy level, the image in the microscope remains in focus (the energy-loss electrons are focused the same as the zero-loss electrons in zero-loss imaging). For spectroscopy, however, using the Offset to move the spectrum is not the optimum, especially if the spectrum is acquired in focused-probe mode (the change in high tension will effectively defocus the probe). For spectroscopy at energy changes less than 1000 Volts typically the drift tube voltage is used. When properly calibrated, the drift tube is easy to use and accurate, without significant hysteresis. For higher energy changes, the prism current is used (possibly in combination with the drift tube).

With the Offset control, the value of the energy loss is chosen. The control panel keeps separate values for the three conditions in which the energy loss can be chosen: Plasmon, Pre-C and Custom. If you type the value, it must be activated by pressing the enter button.

The Energy shift is always set at the voltage indicated, while the Offset and Drift tube are only set to those values when the check box are checked.

MF knobs

The multifunction knobs can be used to control the Offset (MF-X) and the Energy Shift (MF-Y).

Align ZLP

When the Align ZLP button is pressed, the AutoFilter goes through its Align Zero Loss Peak routine, wherein it will attempt to center the zero-loss peak of the energy spectrum in the center of the slit. For proper operation of this function, the slit width should not be too small (at least 10 eV). If the zero-loss peak is only slightly misaligned, the procedure should work under all conditions, but if no previous filtered image has been obtained, make sure that the magnification selected is in the middle of the range (~100 000x) and not too low (where the differential pumping aperture can partially block the beam so the Filter cannot find sufficient intensity).

Filtered Series

When the Filt. Series button is pressed, the Imaging Filter will acquire a filtered series (a series of filtered images at specified starting energy and energy interval).

Thickness Map

When the Thickness Map button is pressed, the Imaging Filter will acquire two images, one filtered, the other unfiltered and from those calculate a thickness map (expressed in mean free path units).

4.8.2 EFTEM On Plasmon

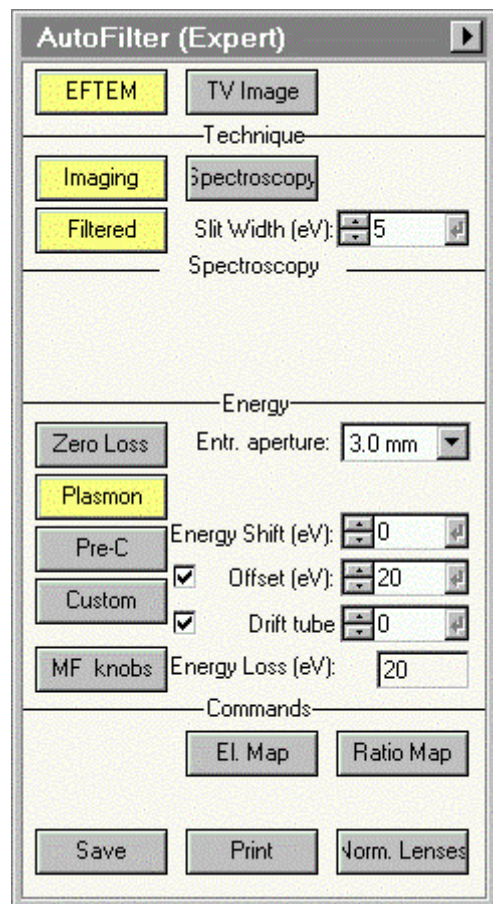

El. Map

When the El. Map button is pressed, the Imaging Filter Elemental Mapping procedure (three-window method) is started. The element settings are those chosen in the AutoFilter Setup.

Ratio Map

When the Ratio Map button is pressed, the Imaging Filter Ratio Mapping procedure (two-window method) is started. The element settings are those chosen in the AutoFilter Setup.

4.8.3 EFTEM Spectroscopy

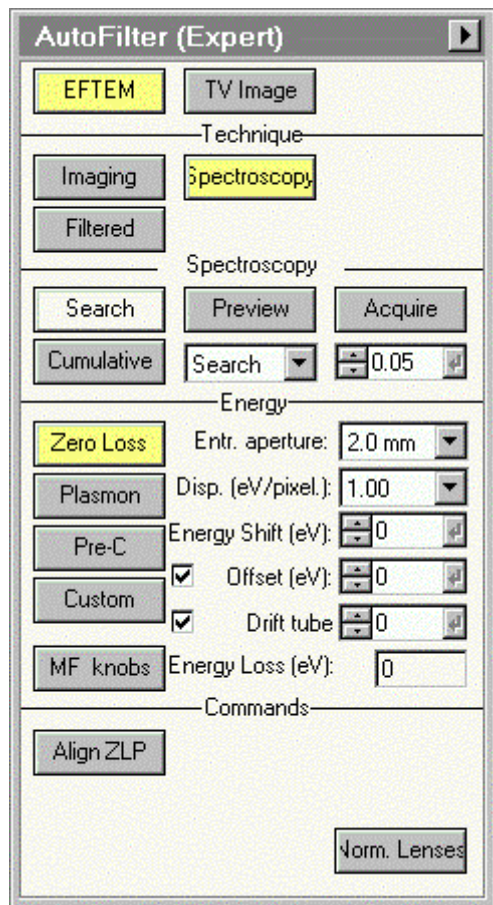

Search, Preview, Acquire

Spectroscopy has three acquisition states which are independent from those of imaging : Search, Preview and Acquire. You can switch from one state to another or switch active acquisition on or off by pressing the Search, Preview and Acquire buttons.

Cumulative

Switches Cumulative acquisition on or off (in cumulative, spectra acquired are added together, otherwise each new spectrum replaces the one acquired previously). If Cumulative was off; the button will turn yellow or stops spectrum acquisition in the Cumulative state. If Cumulative was already on; the button will turn white.

Exposure time

The exposure time for the three spectrum acquisition states can be adjusted by selecting the state through the drop-down box and changing the value of the exposure time. If you type the value, it must be activated by pressing the enter button.

Dispersion (eV/pixel)

The dispersion in spectroscopy (the energy width per pixel) is selected via the drop-list box.

Align ZLP

The Align Zero-Loss Peak function in spectroscopy works different from that in imaging. In spectroscopy you use to set the scale of the EELS spectrum. Operation of the function is as follows:

- Acquire an EELS spectrum (continuous or single acquisition),
- Type in the value of the energy where the zero-loss peak is currently displayed under Energy shift and press the Enter button.
- Press the Align ZLP button.

The energy scale should now have 0 at the position of the zero-loss peak.

4.9 AutoFilter setup

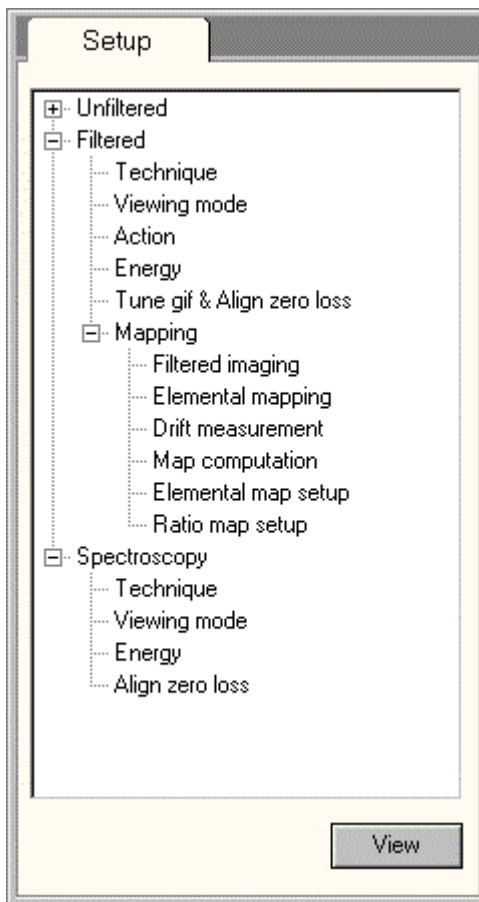
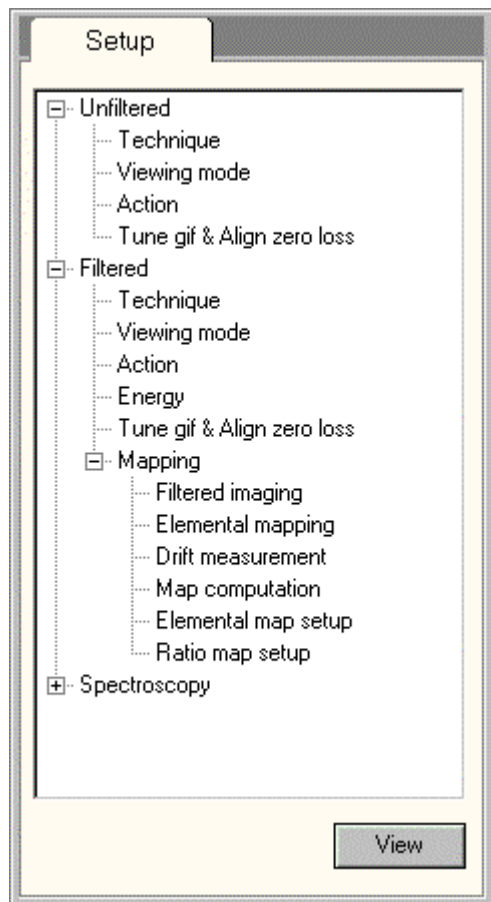

The AutoFilter Setup Control Panel.

The AutoFilter Setup Control Panel gives access to the dialogs in DigitalMicrograph that define the various AutoFilter settings.

Note: This page only shows the dialogs. For an explanation of the functionality see the Gatan documentation.

View

When the View button is pressed, the relevant dialog is brought up in DigitalMicrograph.

4.9.1 AutoFilter Technique Options

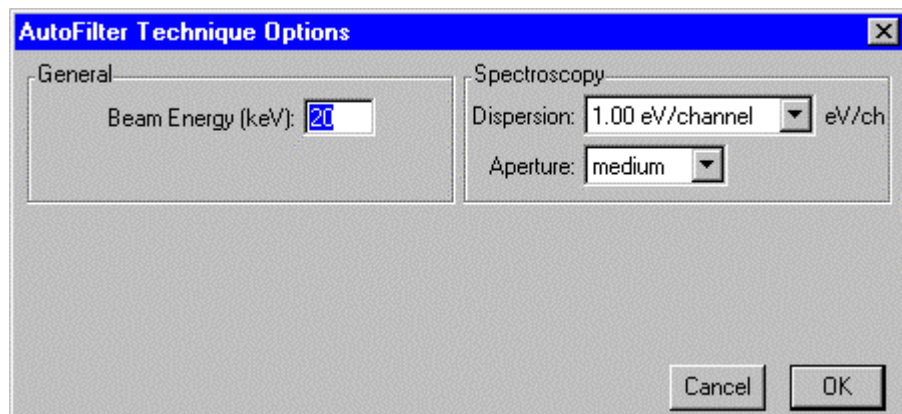

4.9.2 AutoFilter View Options

The screenshot shows the 'AutoFilter View Options' dialog box. It is divided into three main sections: Search View, Focus View, and Preview. The Search View section includes fields for Exposure (sec) set to 0.1, Binning set to 3x3:1 (on-chip), and Mode set to TV. The Focus View section includes Exposure (sec) set to 0.25 and CCD Area parameters: Top (288), Height (96), Left (192), and Width (192). The Preview section includes Exposure (sec) set to 1.0 and Binning set to 2x2:1 (on-chip). At the bottom right, there are 'Cancel' and 'OK' buttons.

4.9.3 AutoFilter Image Recording Options

The screenshot shows the 'AutoFilter Image Recording Options' dialog box. It is divided into three main sections: Acquire, Save, and Processing. The Acquire section includes Exposure Timing set to auto, Auto target counts/pixel set to 10000, Fixed exposure time (sec) set to 1.0, Auto exposure limit (sec) set to 2.0, and Accumulated readouts set to 1. The Save section includes checkboxes for 'Prompt for filename?' and 'Close after saving?', both of which are checked. The Processing section includes dropdown menus for 'Restore MTF' (off), 'Correct distortion' (off), and 'User defined' (off). Below these dropdowns is an empty text input field. At the bottom right, there are 'Cancel' and 'OK' buttons.

4.9.4 AutoFilter Tune GIF Options



4.9.5 AutoFilter Energy Options

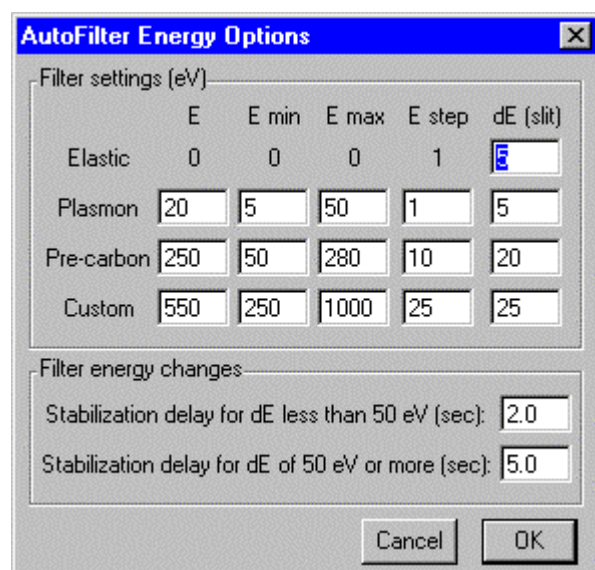

4.9.6 Filtered Imaging Setup

The 'Filtered Imaging Setup' dialog box contains the following fields and controls:

- Detector:** Exposure time (s): 2; Corrections: Dark count & gain (dropdown).
- Preferred CCD Area:** Top: 0, Height: 1024, Left: 0, Width: 1024.
- Filter energy settling times (s):** Large dE: 5, Small dE: 2.
- Binning:** Hardware: 2x2:1 (on-chip), Software: 1:1 (off-chip).

Buttons: OK, Cancel.

4.9.7 Elemental Mapping Preferences

The 'Elemental Mapping Preferences' dialog box contains the following fields and controls:

- 1st pre-edge image:** Name: Pre-edge 1; Readouts averaged: 1.
- Post-edge image:** Name: Post-edge; Readouts averaged: 1.
- 2nd pre-edge image:** Name: Pre-edge 2; Readouts averaged: 1.
- Housekeeping:** Delete (dropdown); old images before acquiring new set.

Buttons: OK, Cancel.

4.9.8 Drift Measurement Preferences

The 'Drift Measurement Preferences' dialog box contains the following fields and controls:

- Technique:** Cross correlation (dropdown); Crispness halfwidth (pixels): 6.
- Reference area:** Maximum variance (dropdown); Size: 256x256 (dropdown).
- Cross-correlation parameters:** Smallest acceptable value: 0.5; Viewing pause (s): 1.
- Drift database housekeeping:** Maximum number of entries: 500; Entry lifetime (months): 6.

Buttons: OK, Cancel.

4.9.9 Map Computation Preferences

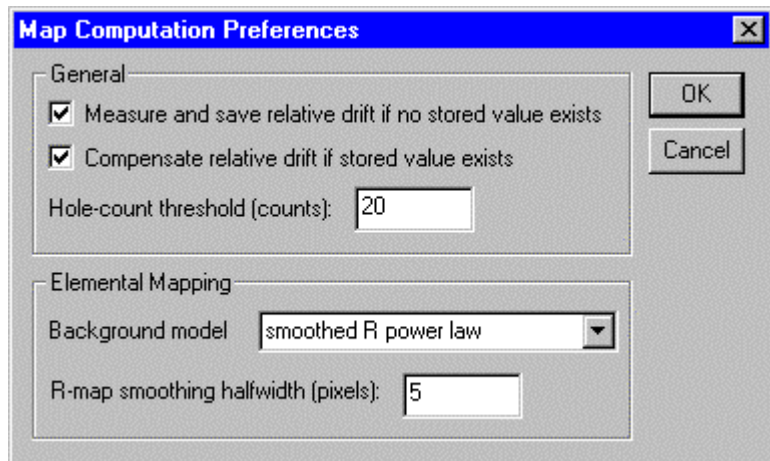

4.9.10 Elemental Mapping Setup

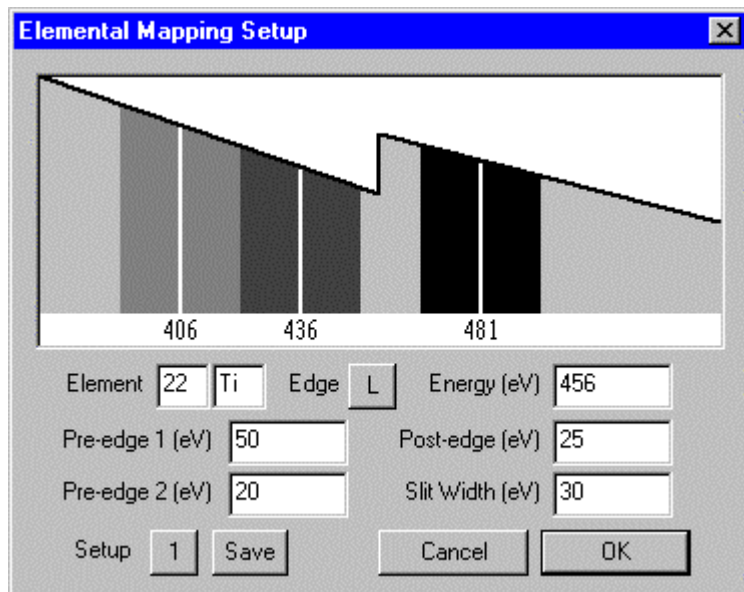

4.9.11 Jump Ratio Mapping Setup

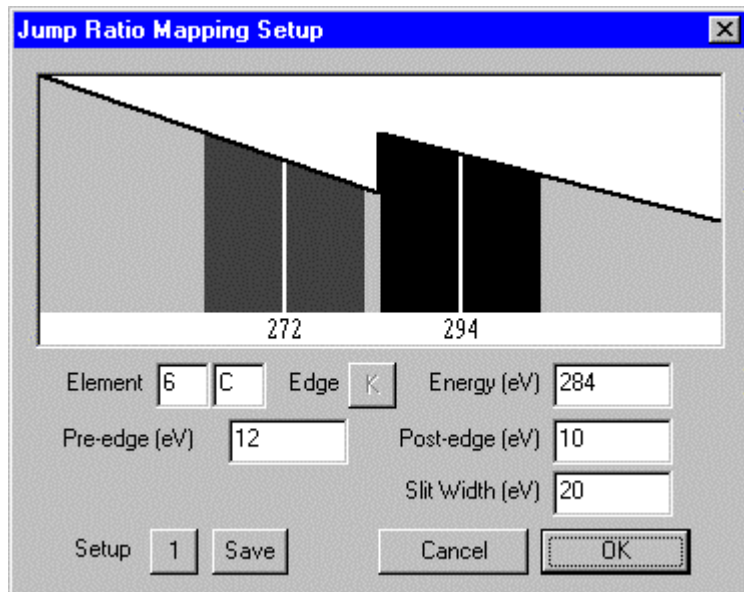

4.9.12 Spectroscopy Setup

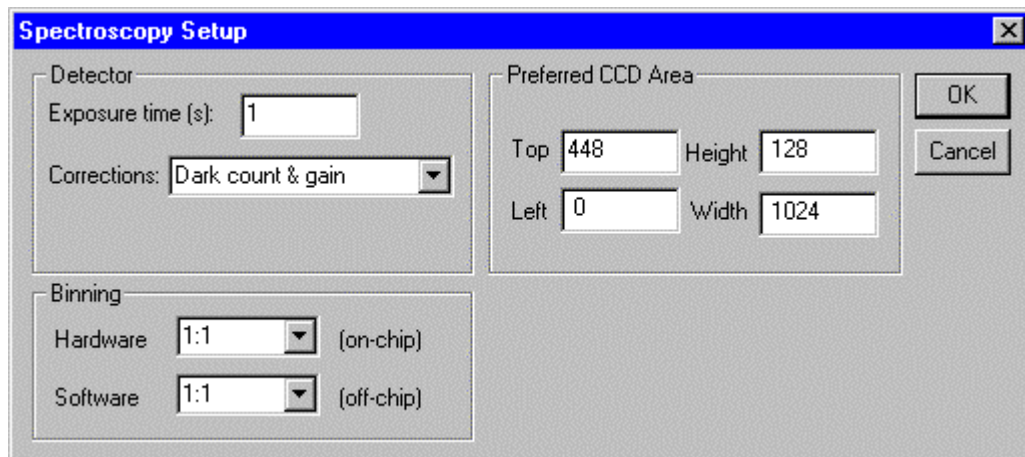

4.10 AutoFilter Tuning (User)

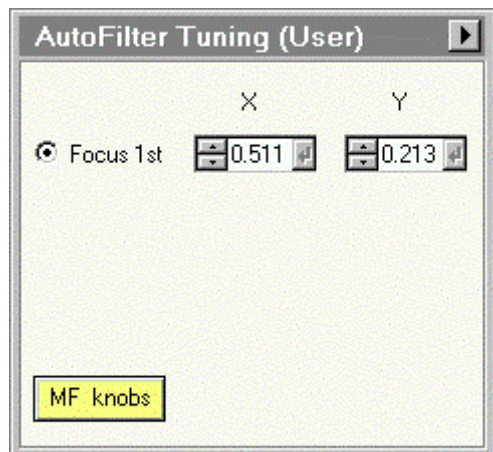

The AutoFilter Tuning Control Panel.

The AutoFilter Tuning control panel contains a controls for focusing the Imaging Filter used for EFTEM. For more background information on EFTEM, see the description of the Energy-Filtered TEM (EFTEM) mode. For imaging, the controls can be used for coarse tuning, since the automatic procedures of the Filter are usually adequate for the fine-tuning. For spectroscopy, the controls may be needed to focus the spectrum properly.

The optics of the energy filter produces some geometrical and energy-dispersive plane aberrations in the image plane. The post-column filter can correct these automatically in imaging mode by pressing the align zero-loss and tune GIF button. When pressing the Align zero-loss button in the AutoFilter window the peak of elastically scattered electrons will be centered in the middle of the energy selecting slit. If in unfiltered mode you see the light but in zero-loss filtered mode the image disappears, it may be due to the zero-loss peak misalignment. With the tune GIF button all aberrations within the post-column filter can be minimized. The settings of the post-column filter for each magnification will be stored after the automatic routine has been successfully finished. The next time this magnification is chosen, it will be recalled. Especially the 1st and 2nd order isochromaticity should be corrected once after the installation of the Tecnai for each magnification, so that reasonable preset values can be reached in daily work.

The Filter can be used optically in two main ways, one for imaging (recreating an "image" of what is received at the entrance aperture), the other for spectroscopy. If the Filter settings selected are double-focusing (the image is in focus and the spectrum is focused at the energy-selecting slit), the corrections are usually similar for imaging and spectroscopy. Where no double-focusing is possible (e.g. the larger dispersions in spectroscopy), the aberration corrections will be different.

The manner of correcting for the aberrations is different for imaging and spectroscopy. Below we will first consider imaging.

4.10.1 Imaging

First we need to describe the concept of isochromaticity. In a perfect filter, the energy across the field of view is the same. If we would introduce an infinitely small slit, the image would either be totally blocked by the slit (dark) or totally transmitted (bright). In practice, there is a small variation in energy across the field of view. In the case of the first-order achromaticity, the effect is a linear change, in the case of the second order it is non-linear.

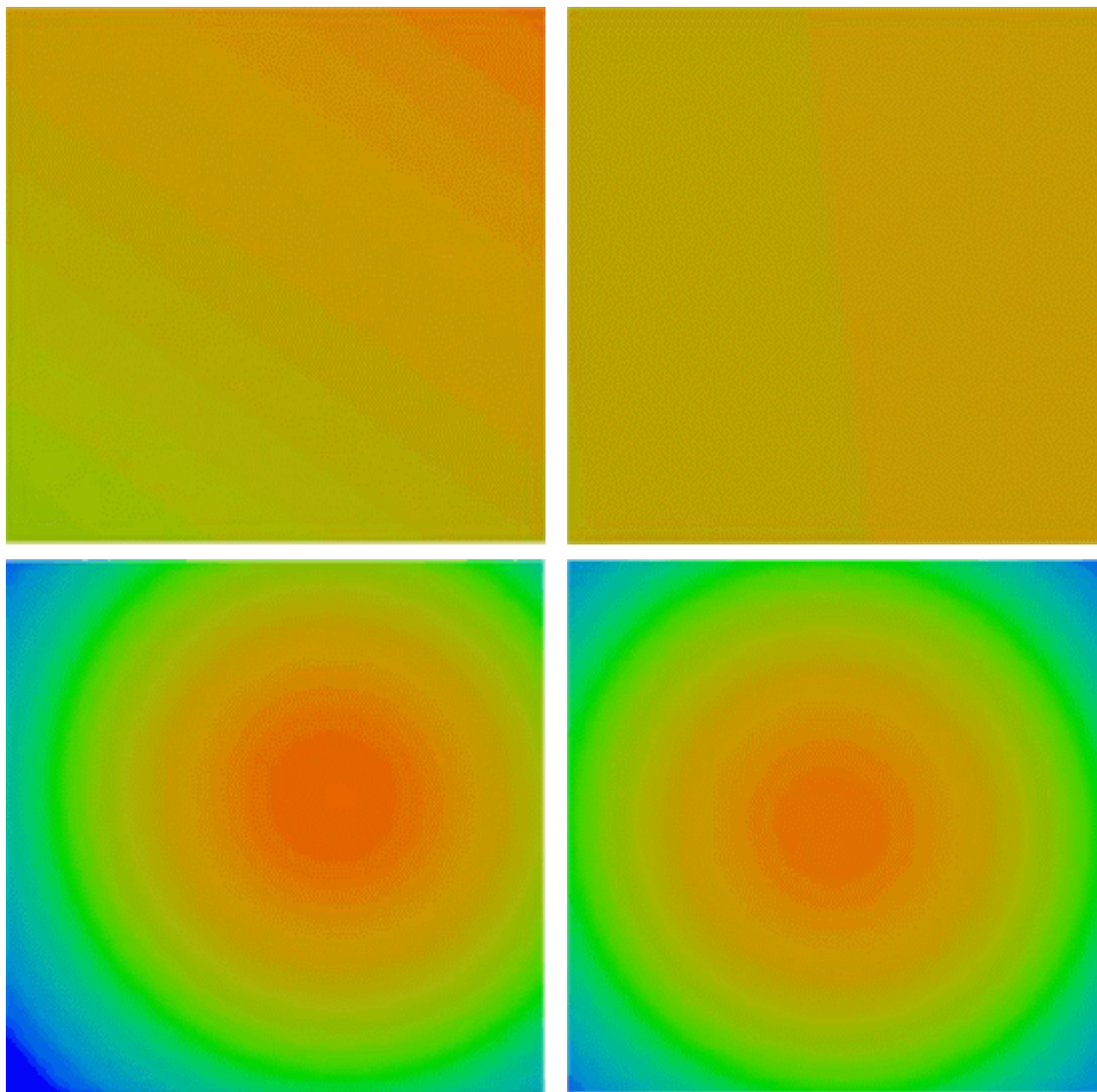

An example of the first and second order isochromaticity correction is shown in the figure above. On the left are the data obtained during the aberration correction procedure before correction and on the right the data after. At the top is the first-order isochromaticity, at the bottom second order.

In the top left image there is a range in energy across the field of view, changing from bottom left to top right, as indicated by the colors which cover a range of 0.16eV. After correction, there still is a change in energy (now more from left to right) but now the total range has decreased to 0.03eV.

The second-order aberration, which produces a circular distribution is not well centered initially, so the energy range from the bottom left corner to the maximum is unnecessarily large (1.8eV). After correction the centering is better and the range is now 1.25eV (from the center to the four corners of the image).

For manual adjustment, insert a small slit (1 to 2 eV) and make sure the beam (zero-loss) passes through the slit. When the 1st order X is changed, the slit will become visible as black bars along the sides of the field of view on either side of the proper focus value. Change the 1st X until the bars are gone (or as small as possible), iterating from over- to underfocus and back to find the optimum. For Y the bars will be at top and bottom.

During these adjustments you may have to recenter the zero-loss energy relative to the slit.

4.10.2 Spectroscopy

In spectroscopy, there are two ways of observing the effects. You can either insert the TV and look at the "image" of the spectrum or you can collect spectra and observe the effect on the zero-loss peak.

When collecting spectra, the aim is to make the zero-loss peak as narrow as possible.



The spectrum on the left is not focused properly, that on the right is.

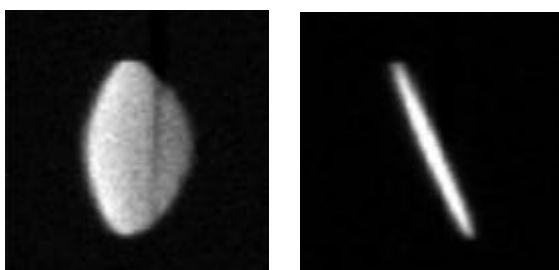

When looking at the image of the spectrum on the TV, the above images can be observed. A perfectly focused spectrum would display a thin vertical line. When the 1st order X is defocused, the line broadens (top left image). When the 1st order Y focus is changed, the line will rotate (top right image).

Note: Because of the position of the TV camera, there is a slight change in spectrum focus between the TV and the CCD. The TV can be used very well for coarse focusing, but for fine focusing always use the CCD.

Focus 1st

The controls for the 1st order achromaticity correction are accessed under Focus 1st X and Y. When the radio button is checked, the MF knobs are connected to these controls (when the MF knobs button is yellow). The controls themselves are standard spin-edit-enter controls.

MF knobs

The Multifunction knobs can be used to change the settings of the Focus 1st function described above. To connect the Multifunction knobs to one of the functions, select the particular functions through its radio button and press the MF knobs button (it will become yellow). You can change the sensitivity of the MF knobs with the MF - and + buttons.

Flap-out button

The flap-out button leads to the AutoFilter Tuning Restore Control Panel.

4.11 AutoFilter Tuning (Expert)

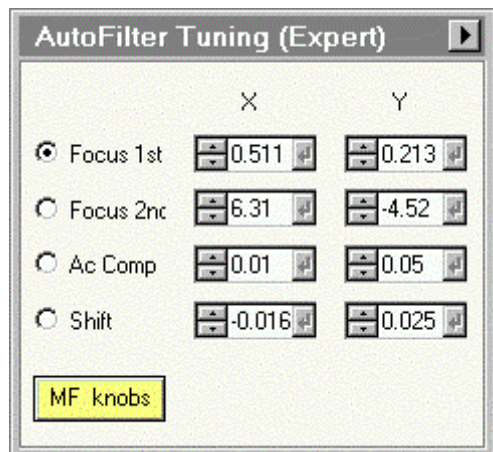

The AutoFilter Tuning Control Panel.

The AutoFilter Tuning control panel contains a number of controls for tuning the Imaging Filter used for EFTEM. For more background information on EFTEM, see the description of the Energy-Filtered TEM (EFTEM) mode. For imaging, the controls can be used for coarse tuning, since the automatic procedures of the Filter are usually adequate for the fine-tuning. For spectroscopy, the controls may be needed to focus the spectrum properly.

The optics of the energy filter produces some geometrical and energy-dispersive plane aberrations in the image plane. The post-column filter can correct these automatically in imaging mode by pressing the align zero-loss and tune GIF button. When pressing the Align zero-loss button in the AutoFilter window the peak of elastically scattered electrons will be centered in the middle of the energy selecting slit. If in unfiltered mode you see the light but in zero-loss filtered mode the image disappears, it may be due to the zero-loss peak misalignment. With the tune GIF button all aberrations within the post-column filter can be minimized. The settings of the post-column filter for each magnification will be stored after the automatic routine has been successfully finished. The next time this magnification is chosen, it will be recalled. Especially the 1st and 2nd order isochromaticity should be corrected once after the installation of the Tecnai for each magnification, so that reasonable preset values can be reached in daily work.

The Filter can be used optically in two main ways, one for imaging (recreating an "image" of what is received at the entrance aperture), the other for spectroscopy. If the Filter settings selected are double-focusing (the image is in focus and the spectrum is focused at the energy-selecting slit), the corrections are usually similar for imaging and spectroscopy. Where no double-focusing is possible (e.g. the larger dispersions in spectroscopy), the aberration corrections will be different.

The manner of correcting for the aberrations is different for imaging and spectroscopy. Below we will first consider imaging.

4.11.1 Imaging

First we need to describe the concept of isochromaticity. In a perfect filter, the energy across the field of view is the same. If we would introduce an infinitely small slit, the image would either be totally blocked by the slit (dark) or totally transmitted (bright). In practice, there is a small variation in energy across the field of view. In the case of the first-order achromaticity, the effect is a linear change, in the case of the second order it is non-linear.

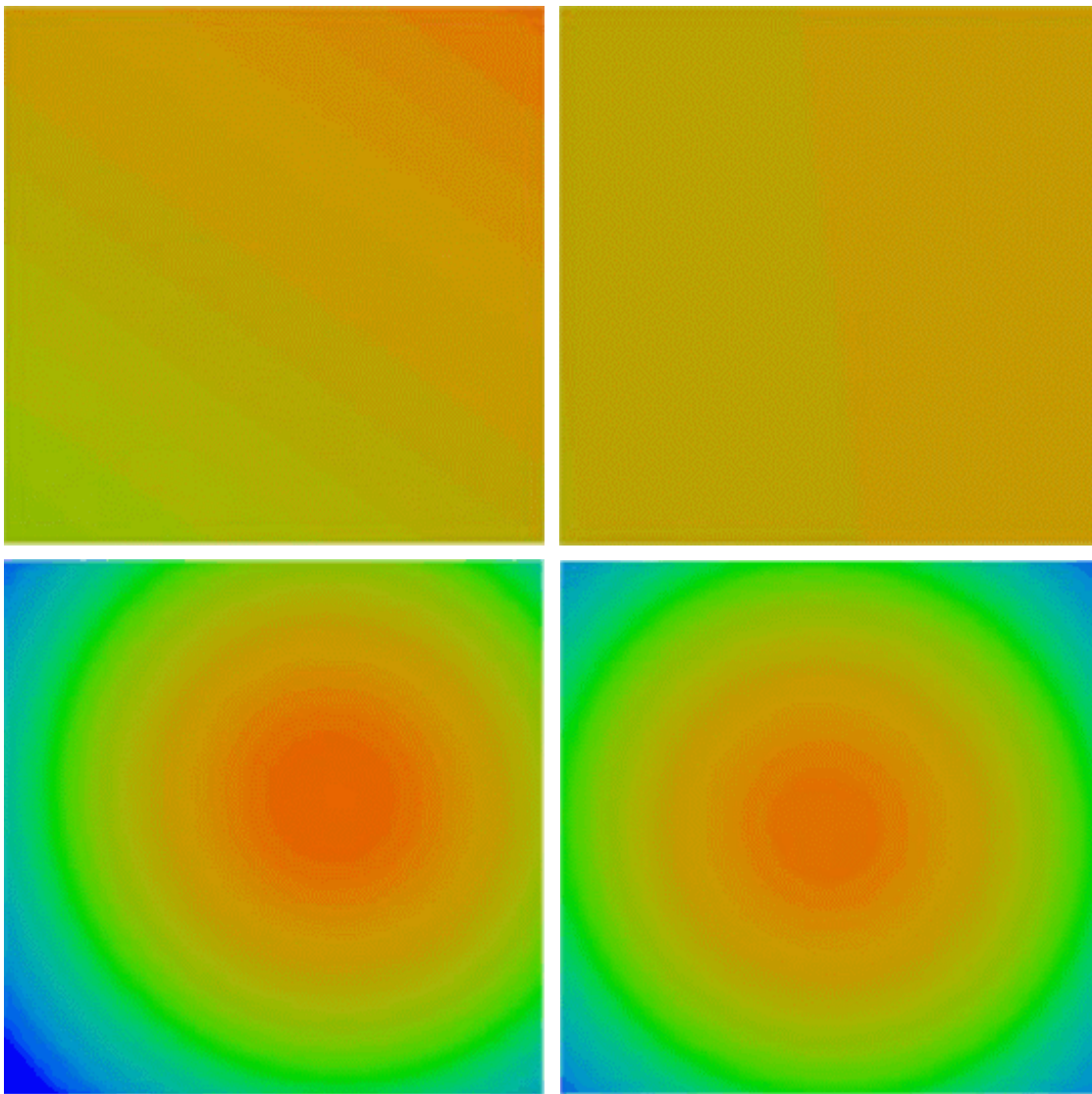

An example of the first and second order isochromaticity correction is shown in the figure above. On the left are the data obtained during the aberration correction procedure before correction and on the right the data after. At the top is the first-order isochromaticity, at the bottom second order.

In the top left image there is a range in energy across the field of view, changing from bottom left to top right, as indicated by the colors which cover a range of 0.16eV. After correction, there still is a change in energy (now more from left to right) but now the total range has decreased to 0.03eV.

The second-order aberration, which produces a circular distribution is not well centered initially, so the energy range from the bottom left corner to the maximum is unnecessarily large (1.8eV). After correction the centering is better and the range is now 1.25eV (from the center to the four corners of the image).

For manual adjustment, insert a small slit (1 to 2 eV) and make sure the beam (zero-loss) passes through the slit. When the 1st order X is changed, the slit will become visible as black bars along the sides of the field of view on either side of the proper focus value. Change the 1st X until the bars are gone (or as small as possible), iterating from over- to underfocus and back to find the optimum. For Y the bars will be at top and bottom.

For the second-order focus, the area blocked by the slit will not be roughly circular but elongated. Optimise until it is circular.

During these adjustments you may have to recenter the zero-loss energy relative to the slit.

4.11.2 Spectroscopy

In spectroscopy, there are two ways of observing the effects. You can either insert the TV and look at the "image" of the spectrum or you can collect spectra and observe the effect on the zero-loss peak.

When collecting spectra, the aim is to make the zero-loss peak as narrow as possible.



The spectrum on the left is not focused properly, that on the right is.

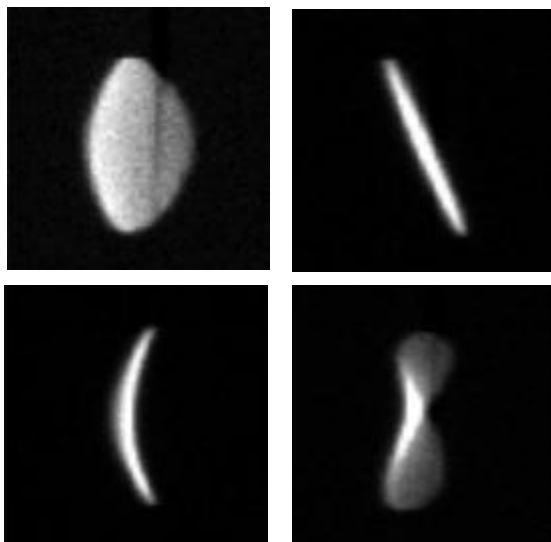

When looking at the image of the spectrum on the TV, the above images can be observed. A perfectly focused spectrum would display a thin vertical line. When the 1st order X is defocused, the line broadens (top left image). When the 1st order Y focus is changed, the line will rotate (top right image). The 2nd order X will cause a curving of the line (bottom image on the left) while the 2nd order Y will give a complex distortion (bottom right-hand image).

Note: Because of the position of the TV camera, there is a slight change in spectrum focus between the TV and the CCD. The TV can be used very well for coarse focusing, but for fine focusing always use the CCD.

Focus 1st

The controls for the 1st order achromaticity correction are accessed under Focus 1st X and Y. When the radio button is checked, the MF knobs are connected to these controls (when the MF knobs button is yellow). The controls themselves are standard spin-edit-enter controls.

Focus 2nd

The controls for the 2nd order achromaticity correction are accessed under Focus 2nd X and Y. When the radio button is checked, the MF knobs are connected to these controls (when the MF knobs button is yellow). The controls themselves are standard spin-edit-enter controls.

Ac Comp

The Ac compensation controls define the Ac (stray field) compensation for the Imaging Filter. The compensation applies a 50 or 60 Hz (dependent on the local situation) frequency in two perpendicular directions, thereby compensating a stray field in the opposite direction. The controls for it are accessed under Ac Comp X and Y. When the radio button is checked, the MF knobs are connected to these controls (when the MF knobs button is yellow). The controls themselves are standard spin-edit-enter controls.

Shift

The shift controls allow the user to shift the spectrum. The controls for the shift are accessed under Shift X and Y. When the radio button is checked, the MF knobs are connected to these controls (when the MF knobs button is yellow). The controls themselves are standard spin-edit-enter controls. Note that the shift shifts both slit and spectrum and has no effect when in imaging mode. Normally the shift is used to set the spectrum to such a position that the inserted slit can be seen on the left-hand side of the TV monitor.

MF knobs

The Multifunction knobs can be used to change the settings of the four Filter elements described above. To connect the Multifunction knobs to one of the functions, select the particular functions through its radio button and press the MF knobs button (it will become yellow). You can change the sensitivity of the MF knobs with the MF - and + buttons.

Flap-out button

The flap-out button leads to the AutoFilter Tuning Restore Control Panel.

4.12 AutoFilter Tuning Restore

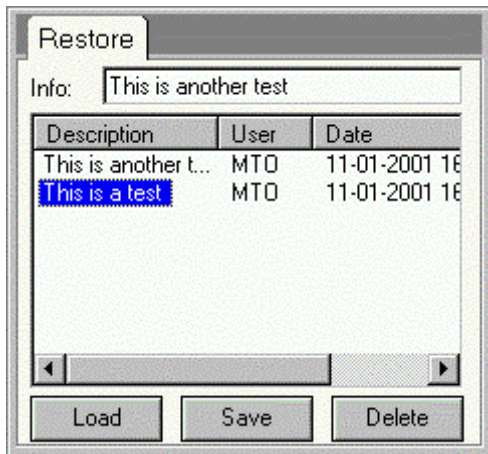

The AutoFilter Tuning Restore Control Panel.

The AutoFilter Tuning Restore Control Panel allows the loading and saving of Imaging Filter setting set via the AutoFilter Tuning control panel. With the settings are stored a comment (entered under Info), the username of the user (the name under which you or another was logged on) and the date and time. All settings are accessible to all users and stored in a single file

Info

The Info entered by the user is included with the file and allows the user to store a comment with the settings.

List

The list contains an overview of the files with settings available, sorted according to the alphabetical order of the description, username or date/time. You can change the sorting by clicking on the buttons at the top of the list (Description, User, ...). Clicking again reverses the order.

Load

When the Load button is pressed, the settings currently selected in the list are loaded and sent to the Imaging Filter.

Save

When the Save button is pressed, the currently active settings are stored.

Delete

When the Delete button is pressed, the currently selected setting is deleted. Note that there is no protection against deleting other users' settings.

4.13 Beam Settings

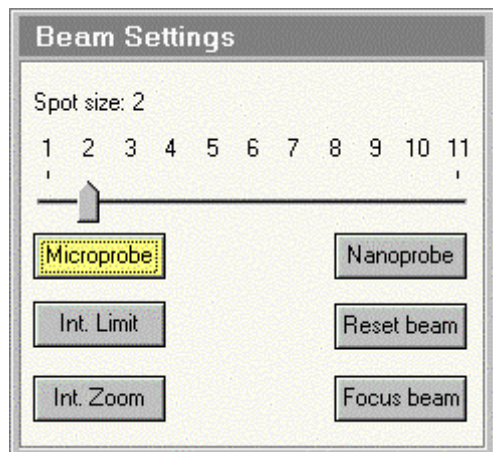

Beam Settings Control Panel.

In the Beam Settings Control Panel various settings related to the illumination system are controlled. In addition a control is present to reset the defocus display of the system to zero.

Spot size

The Tecnai microscope has eleven fixed settings for the spot size (the first condenser lens or C1). The numbering is such that spot 1 is the largest and spot 11 is the smallest spot. The actual spot size also depends on the microscope mode, with larger spots in the microprobe mode and smaller spots in the nanoprobe mode. The spot size is changed by moving the scale indicator along the track bar.

Intensity Limit

In order to prevent damage to a specimen by unintentionally focusing the beam too much, it is possible to block focusing the beam (Intensity) further than a certain point with the Intensity Limit function. Set the Intensity (either underfocus or overfocus - overfocus being clockwise with the knob when the beam has gone through focus) to the maximum degree of focusing desired and press the Intensity Limit button. The button will become yellow (active). Henceforth it is not possible to focus the beam more than that setting. To switch Intensity Limit off, click on the button again.

Note: The Intensity Limit function only works after the Spotsize-Intensity calibration has been done in the Alignment procedures.

Intensity Zoom

When the magnification is changed, the field of view changes and the screen intensity will be going down (high magnification) or up. To keep the same screen intensity, the operator can adjust the Intensity setting. The Tecnai microscope can also automatically change the Intensity setting as a function of magnification, spreading the beam when the magnification is lowered and focusing it when the magnification goes up. To select this function, define a good Intensity setting for the current magnification and then click on the Intensity Zoom button. The button will become yellow (to indicate Intensity Zoom is active). From then on the microscope will keep the screen Intensity constant. At very high magnifications, it may not be possible to achieve the same screen intensity anymore because the beam is already completely focused. In that case the Intensity Zoom will stop and resume again when the magnification is lowered.

Intensity Zoom can be used at the same time as Intensity Limit. In that case, the Intensity Limit defines the maximum focusing of the beam.

Note 1: The Intensity Zoom function only works after the Spotsize-Intensity calibration has been done in the Alignment procedures.

Note 2: The Intensity Zoom function is decoupled between LM, Microprobe (HM) and Nanoprobe (that is, it can be on or off in any of the three independently). When switching between LM and HM, the

Intensity Zoom functions reverts to its previously defined state (when going to Microprobe, if Intensity Zoom was off in Microprobe it will be off, and vice versa).

Reset beam

When the Reset beam button is pressed, the user beam shift (as normally set with the left-hand track ball) is reset to zero. The beam will then be in the position defined in the alignments.

Focus beam

When the Focus beam button is pressed, the Intensity setting is changed to the value at which the beam is focused. This value is defined in the Spotsize-Intensity calibration procedure and the function will only work when this procedure has been done.

Microprobe / Nanoprobe

Microscopes equipped with a TWIN-type objective lens have two operating modes of the lens, the microprobe and nanoprobe modes. The difference between these modes lies in the way the minicondenser lens is used. In the microprobe mode, the minicondenser acts in the opposite direction of the main field of the objective lens, creating a separate lens. In nanoprobe, the minicondenser works in the same direction as the main field and no separate lens field exists.

Switching between the two modes is achieved by clicking on the microprobe or nanoprobe buttons. The active mode is highlighted by the yellow color of its button.

The main characteristics of the two modes are:

Characteristic	Microprobe	Nanoprobe
Purpose	TEM imaging	Analysis, STEM, CBED
Spot size (appr.)	~1000 to 20 nm*	~50 to 1 nm*
Field of view	>largest area seen at lowest MI magnification	Appr. 1/40 of the size of the condenser aperture*
Convergence angles	Low (millirads)	High (tens of millirads)

* somewhat dependent on the type of objective lens

4.14 CCD / TV Camera

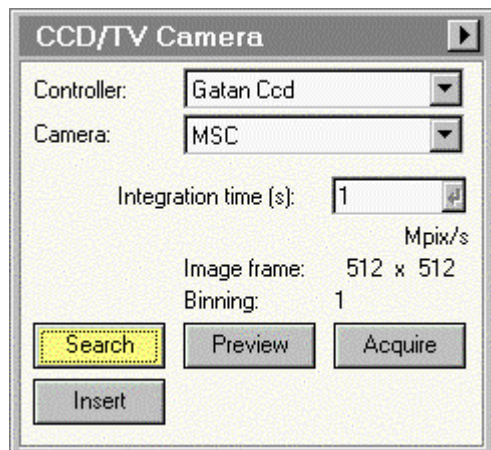

The CCD / TV Camera Control Panel.

The CCD / TV Camera Control Panel allows control over image acquisition using CCD and TV (TV-rate) cameras. In order to allow acquisition, a controller must be present. This controller can be DigitalMicrograph, AnalySIS, TIA or CCD Camera Server (used for Tecnai application software) for CCD images and TIA for TV (Video) images. The controller takes care of the actual image acquisition and display in the 'data space' of the Tecnai user interface.

Note: In order to allow CCD image acquisition on a Gatan CCD camera using TIA, DigitalMicrograph must be running (otherwise TIA cannot access the camera).

For easy operation, the CCD / TV acquisition system has three preset acquisition modes with their own buttons, Search, Preview and Acquire. Each of the three can have its own, separate settings (Integration time, Frame size, Binning), allowing rapid switching between different settings. The actual settings are up to the user. Typical settings could be:

- Search: Integration time 0.2 seconds, Image frame 256*256, Binning 4.
- Preview: Integration time 0.5 seconds, Image frame 512*512, Binning 2.
- Acquire: Integration time 1 second, Image frame 1024*1024, Binning 1.

By definition Search and Preview are continuous acquisition, while Acquire acquires a single frame and stops (to allow the operator to save the image). When DigitalMicrograph is used as controller images are acquired into separate windows (the next acquisition will be in a new window). In the case of TIA the different acquisition modes all acquire into the same image (and Search or Preview can thus overwrite an Acquired image).

Controller

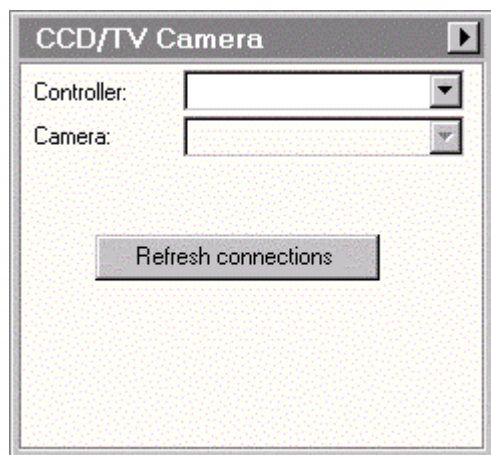

Active controllers (e.g. Gatan CCD, TIA CCD, CCD Camera Server or TIA Video, AnalySIS CCD) are displayed in a drop-down list. Select one of the options to determine the controller to be used.

Note: If no controller is visible or the required CCD camera is missing in the list (while CCD Camera Server should be the controller to be used), you may need to reconnect to the driver. Click on the control panel with the right-hand mouse button and a popup menu with a single line 'Refresh connections' will be visible. Click on the line and a reconnect will be attempted. This function does not work for any other driver (in those cases the "driver" - such as Gatan DigitalMicrograph, TIA, or AnalySIS must be restarted).

Camera

If more than one camera is present (e.g. a slow-scan CCD camera below the projection chamber or in the wide-angle TV port above the projection chamber, and an Imaging Filter), the camera to be used can

be chosen from the drop-down list with cameras. Note that for TIA the actual name of physically the same camera may differ from that used by DigitalMicrograph.

Integration time

The integration time sets the CCD camera integration time for the currently active acquisition mode (Search, Preview, Acquire). Not active for TV-rate camera acquisition.

Mpix/s

Displays the CCD camera read-out rate (in Megapixels per second). Not yet active.

Image frame

The image frame size displays the size in pixels of the image for the currently active acquisition mode (Search, Preview, Acquire).

Binning

Under binning factor of the CCD camera for the current acquisition mode is displayed. Not present for TV-rate camera image acquisition.

Search

Pressing the Search button:

- When the button is gray, switches the acquisition settings to those of the Search mode and starts acquisition.
- When the button is yellow, pauses the acquisition.
- When the button is white, resumes the acquisition (but starting with a new frame) if possible. If the start command could not be given to the CCD/ TV controller, the button will remain white.

By definition Search is continuous acquisition.

Preview

Pressing the Preview button:

- When the button is gray, switches the acquisition settings to those of the Preview mode and starts acquisition.
- When the button is yellow, pauses the acquisition.
- When the button is white, resumes the acquisition (but starting with a new frame) if possible. If the start command could not be given to the CCD/ TV controller, the button will remain white.

By definition Preview is continuous acquisition.

Acquire

Pressing the Acquire button:

- When the button is gray, switches the acquisition settings to those of the Exposure mode and starts acquisition.
- When the button is yellow, pauses the acquisition.
- When the button is white, resumes the acquisition (but starting with a new frame) if possible. If the start command could not be given to the CCD/ TV controller, the button will remain white.

By definition Acquire acquires a single frame and stops (to allow the operator to save the image).

Insert

If the camera is insertable (moves in and out), it can be inserted or retracted by pressing the Insert button.

Flap-out

Pressing the arrow button displays the flap-out with the CCD / TV Camera Acquisition and General Control Panels.

4.15 CCD / TV Camera General

In the CCD / TV Camera General Control Panel various settings related to CCD/TV camera image acquisition are defined. The controls present depend on the controller and type of camera.

4.15.1 AnalySIS CCD

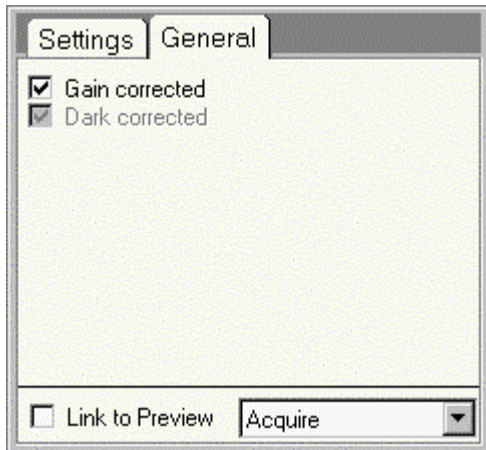

Gain corrected

Under Gain corrected the gain correction of the image acquisition is switched on (checkbox checked) or off.

Dark corrected

Under Dark corrected the dark-current correction of the image acquisition is switched on (checkbox checked) or off.

Link to Preview

The Acquire acquisition mode settings can be defined as totally independent or they can be linked to the Preview settings. In the latter case, any change in the Preview settings will automatically be used in Acquire as well (the typical difference then being that Preview is continuous acquisition while Acquire results in a single image).

Acquisition mode

In the acquisition mode drop-down list, the acquisition mode for which the parameters must be defined, can be selected. The difference between selecting the acquisition mode through the drop-down list and by pressing the equivalent button in the main control panel is that the drop-list selection selects the mode but does not automatically start acquisition.

4.15.2 DigitalMicrograph CCD

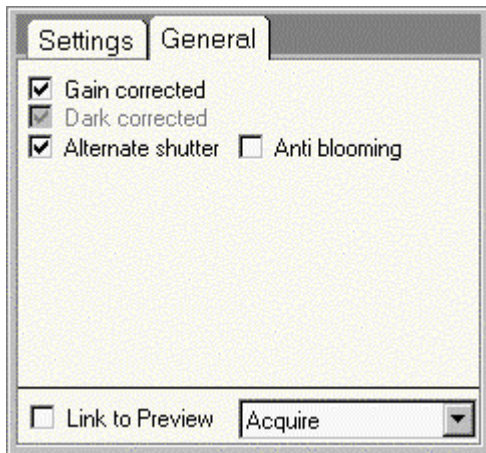

Gain corrected

Under Gain corrected the gain correction of the image acquisition is switched on (checkbox checked) or off.

Dark corrected

Under Dark corrected the dark-current correction of the image acquisition is switched on (checkbox checked) or off.

Anti blooming

Under Anti blooming the anti-blooming option (reduces blooming) of the CCD camera is switched on (checkbox checked) or off.

Alternate shutter

Under Alternate shutter is determined which shutter is used, the normal or the alternate shutter (checkbox checked). On all systems the alternate shutter is a beam blanker (the beam is blanked before the specimen). The alternate shutter is the shutter used for beam-sensitive specimens.

Caution: When the alternate shutter is selected, the microscope software cannot override the blanking signal that is typically activated when the screen is raised (if the CCD camera is located underneath the viewing screen). If plate exposures are taken under these conditions, the beam will remain blanked and no image will be recorded on the plate (only the plate label). If low dose images are recorded, inform low dose about the presence of the CCD camera (see further under low dose). If regular images are recorded, make sure the beam is not blanked by the CCD (switch the alternate shutter off, or either retract a retractable CCD camera or insert the TV-rate camera on an Imaging Filter).

The normal shutter is either the microscope shutter (the same as used for the plate camera) or, in case of the Imaging Filter, a separate shutter in the Imaging Filter itself. Neither of these will interfere with plate-camera exposures.

Link to Preview

The Acquire acquisition mode settings can be defined as totally independent or they can be linked to the Preview settings. In the latter case, any change in the Preview settings will automatically be used in Acquire as well (the typical difference then being that Preview is continuous acquisition while Acquire results in a single image).

Acquisition mode

In the acquisition mode drop-down list, the acquisition mode for which the parameters must be defined, can be selected. The difference between selecting the acquisition mode through the drop-down list and by pressing the equivalent button in the main control panel is that the drop-list selection selects the mode but does not automatically start acquisition.

4.15.3 TIA CCD

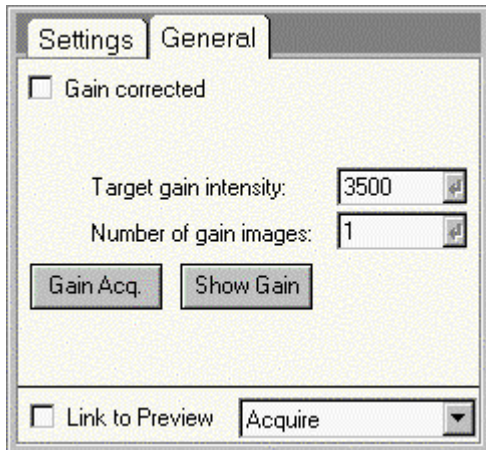

Gain corrected

Under Gain corrected the gain correction of the image acquisition is switched on (checkbox checked) or off.

Target gain intensity

Under Target gain intensity is defined the target intensity used for the acquisition of the gain image(s). Typically this value is set halfway in the full range of the CCD camera (~8000). The software then automatically adjusts the exposure time to reach the target intensity in the gain image(s). Make sure the beam is sufficiently intense to avoid excessively long exposure times (set the beam intensity to have the target intensity level in an image recorded at ~1 sec exposure).



Number of gain images

Under Number of gain images is defined the number of images that is averaged for the final gain image. Typically an average of 5 is used.

Gain Acq.

Pressing Gain Acq. starts image acquisition of the gain image(s). Make sure no specimen is visible on the area covered by the CCD and that the beam is sufficiently intense to avoid excessively long exposure times (set the beam intensity to have the target intensity level in an image recorded at ~1 sec exposure).

To check if the required intensity is set:

- Start continuous image acquisition (Search or Preview) without gain correction for an exposure time of 1 second and no binning (factor 1).
- Select showing the TIA control panels (press toolbar button ) and select the video control panel ( tab).
- If necessary adjust the lower and upper scale of the histogram to 0 and 16000 (double-click on the histogram and enter the numbers in Histogram range dialog that pops up).
- Adjust beam intensity until the video levels in the histogram are approximately in the middle of the histogram range.

Alternative method:

- Collect a CCD image (Acquire) without gain correction for an exposure time of 1 second and no binning (factor 1).
- Double-click on the image and read off the lower and upper scale limits. If these are near the target intensity, you can continue. Otherwise adjust the intensity on the microscope and repeat.

Show gain

When the Show gain button is pressed, TIA will display the gain image (for inspection).

Link to Preview

The Acquire acquisition mode settings can be defined as totally independent or they can be linked to the Preview settings. In the latter case, any change in the Preview settings (exposure time, binning, etc.) will automatically be used in Acquire as well (the typical difference then being that Preview is continuous acquisition while Acquire results in a single image).

Acquisition mode

In the acquisition mode drop-down list, the acquisition mode for which the parameters must be defined, can be selected. The difference between selecting the acquisition mode through the drop-down list and by pressing the equivalent button in the main control panel is that the drop-list selection selects the mode but does not automatically start acquisition.

4.15.4 TIA Video

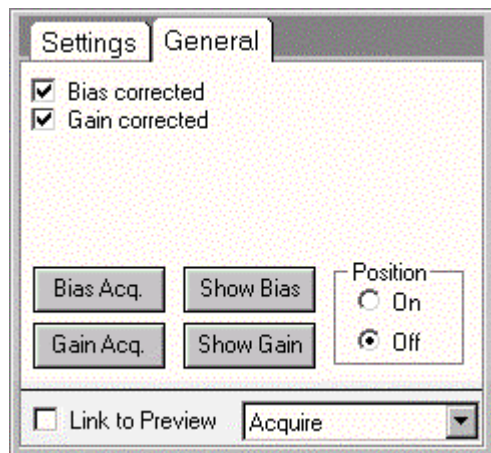

Gain corrected

Under Gain corrected the gain correction of the image acquisition is switched on (checkbox checked) or off. The gain correction for a TV-rate camera is analogous to the gain correction for a CCD camera.



Bias corrected

Under Bias corrected the bias correction of the image acquisition is switched on (checkbox checked) or off. The bias correction for a TV-rate camera is analogous to the dark-current correction for a CCD camera.

Gain Acq.

Pressing Gain Acq. starts image acquisition of the gain image(s). Make sure no specimen is visible on the area covered by the TV camera and that the beam is sufficiently intense to avoid excessively long exposure times (set the beam intensity to have the target intensity level in an image recorded at ~1 sec exposure).

To check if the required intensity is set:

- Start continuous image acquisition (Search or Preview) without gain correction for the same exposure time as for the gain correction image.
- Select showing the TIA control panels (press toolbar button ) and select the video control panel ( tab).
- If necessary adjust the lower and upper scale of the histogram to 0 and 16000 (double-click on the histogram and enter the numbers in Histogram range dialog that pops up).
- Adjust beam intensity until the video levels in the histogram are approximately in the middle of the histogram range.

Alternative method:

- Collect a TV image (Acquire) without gain correction.
- Double-click on the image and read off the lower and upper scale limits. If these are near the target intensity, you can continue. Otherwise adjust the intensity on the microscope and repeat.

Show gain

When the Show gain button is pressed, TIA will display the gain image (for inspection)..

Bias Acq.

Pressing Bias Acq. starts image acquisition of the bias image(s). Make sure no beam is falling on the TV camera (lower the viewing screen).

To check if the required intensity is set:

- Start continuous image acquisition (Search or Preview) without gain correction for the same exposure time as for the gain correction image.
- Select showing the TIA control panels (press TIA toolbar button) and select the video control panel (tab).
- If necessary adjust the lower and upper scale of the histogram to 0 and 16000 (double-click on the histogram and enter the numbers in Histogram range dialog that pops up).
- Adjust beam intensity until the video levels in the histogram are approximately in the middle of the histogram range.

Alternative method:

- Collect a TV image (Acquire) without gain correction.
- Double-click on the image and read off the lower and upper scale limits. If these are near the target intensity, you can continue. Otherwise adjust the intensity on the microscope and repeat.

Show bias

When the Show bias button is pressed, TIA will display the bias image (for inspection).

Position

On microscopes where more than one camera is mounted and the control through these is such that the microscope is not able to tell from the selected camera which it is and where it is located (such as when controlled by a switchbox), the switch between on-axis and off-axis position can be made by selecting the appropriate radio button under Position.

Link to Preview

The Acquire acquisition mode settings can be defined as totally independent or they can be linked to the Preview settings. In the latter case, any change in the Preview settings (exposure time, binning, etc.) will automatically be used in Acquire as well (the typical difference then being that Preview is continuous acquisition while Acquire results in a single image).

Acquisition mode

In the acquisition mode drop-down list, the acquisition mode for which the parameters must be defined, can be selected. The difference between selecting the acquisition mode through the drop-down list and by pressing the equivalent button in the main control panel is that the drop-list selection selects the mode but does not automatically start acquisition.

4.16 CCD / TV Camera Settings

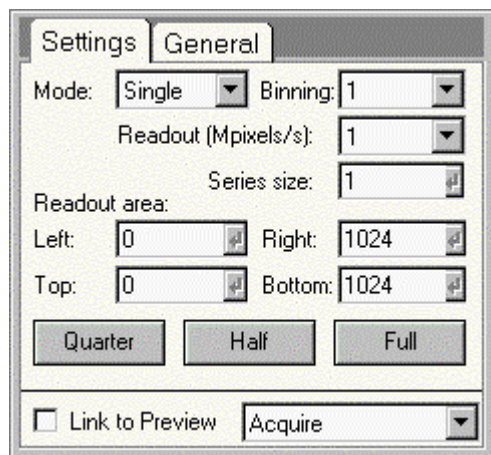

The CCD / TV Camera Settings Control Panel

In the CCD / TV Camera Settings Control Panel the CCD camera acquisition parameters are defined. For an explanation of the CCD basics, see the explanation of the CCD cameras (Section 4.17).

Mode

Under Mode the acquisition mode (continuous or single) is selected. In Continuous the image is acquired continuously until the user stops acquisition. In Single image is acquired after which acquisition stops. Search and Preview are typically set to continuous, while Acquire is set to single.

Binning

Under binning the binning factor of the CCD camera is selected. For Search the binning factor typically is between 2 and 4, for Preview 1 and for Acquire 1.

Readout (TIA only)

Not yet in operation.

Series size (TIA only)

Under Series size the number of images acquired in a TIA series is defined.

Readout area

The readout area of the CCD camera can be set by entering appropriate numbers (and pressing the the Enter button when a number has been changed) or pressing one of the buttons (Quarter, Half, Full) underneath.

Quarter, Half, Full buttons

With the Quarter, Half and Full buttons that CCD camera readout area can be set to 1/4, 1/2 and the full size of the CCD, respectively. These images are always centered, so Quarter corresponds to pixels 384 to 640 (for a 1024x1024 camera) in both x and y directions, while Half corresponds to pixels 256 to 768.

Link to Preview

The Acquire acquisition mode settings can be defined as totally independent or they can be linked to the Preview settings. In the latter case, any change in the Preview settings (exposure time, binning, etc.) will automatically be used in Acquire as well (the typical difference then being that Preview is continuous acquisition while Acquire results in a single image).

Acquisition mode

In the acquisition mode drop-down list, the acquisition mode for which the parameters must be defined, can be selected. The difference between selecting the acquisition mode through the drop-down list and by pressing the equivalent button in the main control panel is that the drop-list selection selects the mode but does not automatically start acquisition.

4.17 CCD camera acquisition

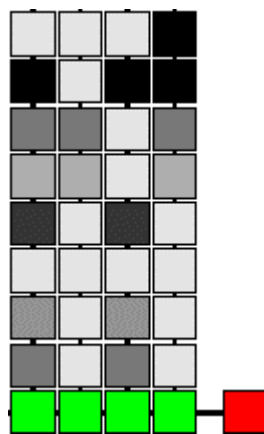

A CCD camera (Charge-Coupled Device) is a camera that consists of a two-dimensional array of light-sensitive elements. When struck by light, the elements generate electrons that are stored inside the element until the camera is read-out. On a so-called slow-scan CCD camera an image is acquired by letting the electrons from the beam strike the camera for the full integration time (so an image is acquired in a single cycle; TV-rate CCD cameras also exist). The read out is done by an Analog-to-Digital Converter (ADC) that lies at the end of a special row on one side of the light-sensitive element array. The result is a digital signal (a value) for each element.

Schematic diagram of part of a CCD camera. The green elements are the pixels of the read-out line from where the signal is shifted to the ADC (red), while the gray elements are the image pixels, showing different image intensities.

A CCD camera typically used in the TEM consists of an array of 1024x1024 elements. In one direction these elements are connected by 'wiring'. Through the connections the whole image can be shifted row by row. During read-out the whole array is shifted one row down so the contents of the last row move into the read-out line. The contents of the read-out line are then moved sideways into the ADC where each pixel is read out individually. Then the whole array is shifted down again, and so on.

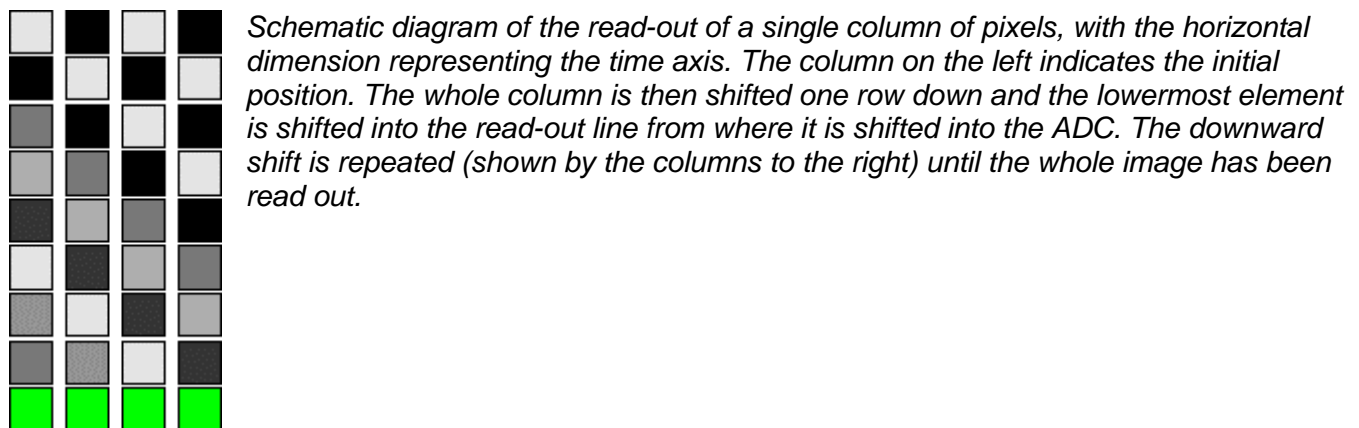

Because the whole image shifts during read out, the camera must be blanked during the read-out, otherwise image acquisition continues during the image shifting and the image will be blurred in one direction.

In order to be useful for imaging with a CCD, the electrons of the beam are first converted to light. This is done through a scintillator - a material that emits light when struck by electrons. Two types of scintillator are commonly used, single-crystal YAG (Yttrium-Aluminium Garnet) and phosphor. YAG is most commonly used in applications where the electron-conversion ratio should be low (e.g. diffraction in materials science). Phosphor is used in life science applications and at high voltages (300 kV).

In principle a CCD camera could be exposed directly to electrons (instead of using light to generate electrons). In practice this is not done for two reasons, one being that conversion to light is more efficient in generating charge in the elements (each incoming electron results in more than one electron stored - the conversion depending on the type of phosphor and typically being around 1:3 for YAG and 1:15 for phosphor). The other reason is that the high-energy electrons of the beam in the TEM will damage the CCD.

One disadvantage of converting electrons to light first is that the electrons are scattered in the scintillator and part of the light signal from one electron ends up in adjacent pixels instead of the pixel directly underneath the position where the electron struck. This causes a loss of resolution in CCD cameras so pixels must be sufficiently large to limit the resolution loss to acceptable values (there isn't much point of employing a camera with e.g. 4096x4096 pixels if the resolution of the camera is equivalent to 4x4 pixels; in that case a cheaper and faster 1024x1024 pixel camera with pixels 4x larger is a better option).

4.17.1 CCD camera parameters

Read-out area

The area of the CCD that is read out can have any rectangular shape. Thus it is possible to read out a single line of 1024 pixels, or all 1024x1024 pixels, or 456x123 pixels (or any other set of numbers) anywhere on the CCD. Reading out a subarea of the CCD is faster than reading out the whole CCD. The charge in the pixels not used is simply flushed out and not read. Because it goes by area, read-out of 1/4th of the area of the CCD is about $4 \times 4 = 16$ times faster than reading out the whole area. For faster read-out but still good resolution (focusing), a subarea read-out is typically chosen.

Binning

Another method to get a faster read out is binning. In this case the contents of adjacent pixels are added together before being read out. A binning factor of 2 means that 2x2 pixels are taken together, while binning 8 means 8x8 pixels together. The advantage of binning over reading out a subarea is that the whole area of the CCD is seen (the image covers a larger area of the specimen, so it is typically used for searching). The disadvantage of binning is the fact that the exposure time or illumination must be adjusted. Because the pixels are added together before the read-out, the same maximum video level that can be read out before saturation of the camera (say 14-bit or 16384) now applies to the pixels together. So for binning 8 the maximum video level that can be allowed on the camera is 1/64th of that for no binning.

Read-out rate and video levels

The read-out of a CCD array is a (relatively) time-consuming step (individual read outs are fast, but because of the large number of rows to read out it is still time-consuming). The read out can be speeded up in some CCDs, so a higher speed is possible (e.g. the Turbo mode on Gatan CCDs). This goes at the expense of the video levels however. The highest-frequency read out typically has an image depth of 8-bit (256 gray levels which is normally sufficient for viewing), intermediate speeds may be 12-bit (4096 gray levels), while the best (but slowest) read-out typically goes to 14-bit (16384). Because of the gain variation (see below) the maximum usable video level (the highest-intensity pixel) is usually around 14000 for a 14-bit camera.

Dark current

The dark current is a current that is present even when no signal falls onto the CCD camera. The dark current builds up slowly in the camera elements. It is therefore dependent on the integration time. For high-quality imaging the dark current is subtracted from the image as read out. When the same integration time is used, the dark current will remain the same, so the dark current is typically only read out only when the integration time is changed and no 'dark-current image' (an image read out after an integration time in which no signal is allowed to fall on the CCD) is already present (dark-current images are typically kept in memory for the current microscope session). In order to make the dark current reproducible, the CCD camera is always flushed (the image is shifted out of the camera - without actually reading it) one or more times just before a real exposure is made.

The dark current is one main reason for using a slow-scan CCD. Because only a single-readout is made, the dark current contributes only once to the image. Whereas in TV-rate cameras the dark-current contributes to the image in each read-out cycle (tens of times per second) so even if the image is integrated (many read-outs taken together) the image quality is less because of the multiple dark-current contribution.

Gain

There is some variation between different elements in a CCD camera, so if uniform illumination falls on a CCD camera there are still differences in signal intensity between the different pixels. This variation is due to variations in size or effectiveness of the elements (high-frequency variation) and due to the fact that scintillator is not completely homogeneous (low-frequency variation). These variations can be corrected by collecting a gain image (an image taken with uniform illumination and then recalculated to the inverse of the maximum intensity in the image - that is, find the maximum in the image collected and for each pixel divide that value by the actual value of the pixel) and multiplying each image collected with the gain image (multiplication is done rather than division because that is faster on a computer, so the division is done only once, when the gain image is acquired).

Gain images are stored on disk and retrieved automatically by the software. The gain images should be checked and, if necessary, updated on a regular basis. It is easy to judge if it necessary to acquire new gain images. Simply collect an image with no specimen visible (e.g. in a hole) with uniform intensity. If

the image only shows noise, the gain images are still good. If features are seen in the image, the gain correction must be updated.

One effect of the application of the gain correction is the appearance of a negative gain correction image when the CCD is saturated (too much beam intensity or integration time too long). If you see features that look like the gain correction image (very often circular bands or a hexagonal chickenwire pattern) and gain correction is on, very likely the camera is saturated. Decrease the integration time or reduce the beam intensity. (The circular bands come from the scintillator; the chickenwire pattern from the fiber-optic coupling between the scintillator and the CCD chip: bundles of optical fibers that ensure a high efficiency of transfer of light from the scintillator to the CCD.)

Blooming

Because the elements of the CCD must be connected in the direction of the columns (otherwise it would be impossible to read out the CCD), charge from one element can overflow into adjacent elements along a column. Along rows this effect is much less because the columns are typically separated by so-called trenches that prevent charge flowing in the row direction.

Blooming is often seen with very high-intensity beams (central beam in a diffraction pattern or the small, focused beams as used during analysis) on the CCD camera, giving a pattern like a very elongated, white ellipse. Avoid this situation as much as possible (the intense beams can leave 'ghost' images that remain visible for a long time unless the cooling of the CCD is switched off). If weak diffraction spots must be recorded, either shift the diffraction pattern so the intense central beam does not hit the CCD camera or collect multiple images with a shorter integration time and add them together to improve the signal-to-noise ratio).

Cooling

In order to reduce the dark current, slow-scan CCDs are typically cooled with a Peltier cooler to temperatures between -20 and -40°C. Because it can take a while for a camera to cool down to its working temperature, it is generally best to keep the cooling on all the time. It may be necessary to switch the cooling off for a while if persistent 'ghost' effects remain visible in the images (easy to check by collecting images with the CCD camera not in the beam or the screen down if the camera is located below it). If the 'ghost' effects cannot be erased by flooding the CCD with a high but uniform intensity, switch the cooling off for several minutes while collecting images with no beam on the camera.

4.18 TV camera acquisition

TV (TV-rate) cameras can be used to acquire TEM images. Because the image quality of TV-rate cameras is at best mediocre, they are most often used for focusing and stigmatation of the image before the actual image is acquired on plate or a slow-scan CCD camera. The big advantage of TV-rate cameras over slow-scan CCD cameras is the high frequency of the image, giving a live image.

TV-rate cameras consist of a device that can detect light. The light is generated by allowing the electrons from the beam to fall on a scintillator that converts electrons to light. Because the light signals from electron images are often weak, many TV-rate cameras have image intensifiers, where the originally weak image is amplified to a usable level.

There are two main types of TV-rate cameras, cameras with tubes and CCD cameras. In the tube cameras a beam scans across the area where the image is and puts out a signal that changes when the amount of light changes. CCD (Charge-Coupled Devices) are similar to the slow-scan CCDs except that the image is not digitized. In both tube- and CCD-cameras the signal is put out continuously and normally fed into a monitor that scans with the same frequency as the camera itself. The frequency and

the number of lines per frame and pixels per line depends on the (electricity) mains cycle. For 50 Hertz there are 512x480 (PAL) while for 60 Hertz there are fewer lines and pixels (NTSC).

On the Tecnai microscope TV-rate camera signals can be fed into stand-alone monitors. The signal can also be fed into a frame-grabber board in the PC and then read out through TIA and displayed on the monitor of the Tecnai microscope. In the latter case images can also be acquired and stored to disk.

4.19 Control Pad Lighting

The left-hand and right-hand pads have green background lighting available to make it easier to locate the controls on the pads when working in the dark. The lighting of both pads can be switched on and off. In addition the intensity of the LEDs (the small yellow status lights) can be adjusted to the room lighting conditions.

To switch the lighting on or off, click on the control panel list in the lower bottom right of the screen (in normal status display).



Select the item listed as 'Control Pads'. The following control panel will pop up.

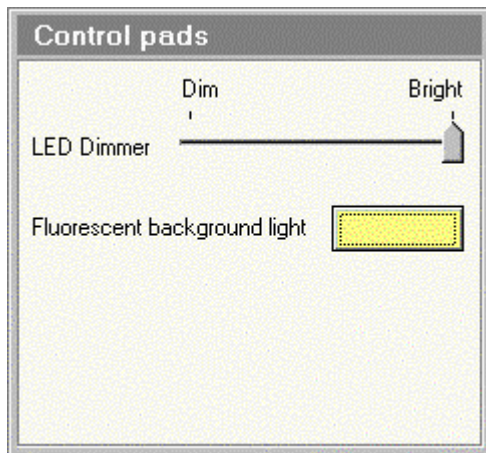

Press the button to switch background lighting on (button becomes yellow) or off. Move the track bar to the left to make the LEDs dimmer and to the right to make them brighter.

4.20 Dark Field

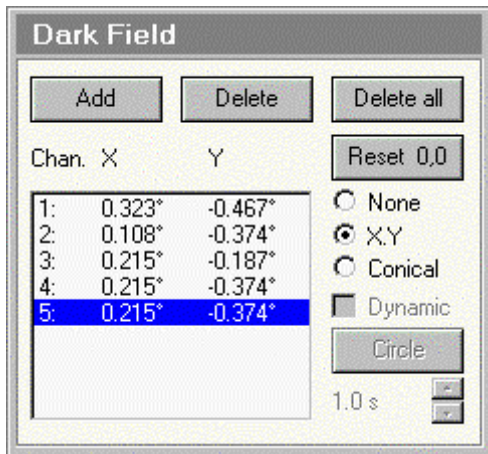

The Dark Field Control Panel.

The Dark Field Control Panel allows control of dark-field imaging. The beam tilts are set with the Multifunction-X,Y knobs.

Add

Add a channel to the list. The new value will be equal to the currently active tilt setting.

Delete

Deletes the currently active channel from the list.

Delete all

Clears the whole list of stored dark-field tilt settings.

Reset 0,0

Resets the currently active channel to 0,0 tilt (that is, no beam tilt).

Channel

An unlimited number of dark-field tilt settings can be stored. Each setting is stored in a channel.

None

Switch Dark Field off (the equivalent of pressing the Dark Field button on the right-hand control pad).

XY

Tilt the beam in X-Y mode, where a beam tilt in one direction (X) is set with the Multifunction-X knob and the tilt in the perpendicular direction is set with the Multifunction-Y knob.

Conical

Tilt the beam in conical mode, where a tilt angle is set with the Multifunction-Y knob while turning the Multifunction-X changes the azimuth angle of the tilted beam.

4.20.1 Dynamic conical dark field

On STEM systems, it is possible to have the microscope drive the beam, around in conical dark field (dynamic conical dark field or hollow-cone illumination).

Note 1: For dynamic conical dark field the AC (STEM) beam deflection coils are used instead of the DC (TEM) beam deflection coils (because it is not possible to control the DC coils with an external signal). This has a number of consequences:

- TIA (Tecnai Imaging & Analysis) must be running because this is the software that drives the beam in a circle.
- The pivot points and other adjustments like calibrations are independent of those of the DC coils used for static dark field and must be set separately.
- The switch between static and dynamic conical dark field means switching between the DC and AC coils. The software will keep the tilt angle as much as possible identical but differences may occur.
- The maximum tilt angle in static conical dark field is quite a bit larger than for dynamic conical dark field.
- Dynamic conical dark field is not supported (no alignment possibilities) in LM (since the dark-field tilt angles there are so small that there is no point in supporting dynamic conical dark field).

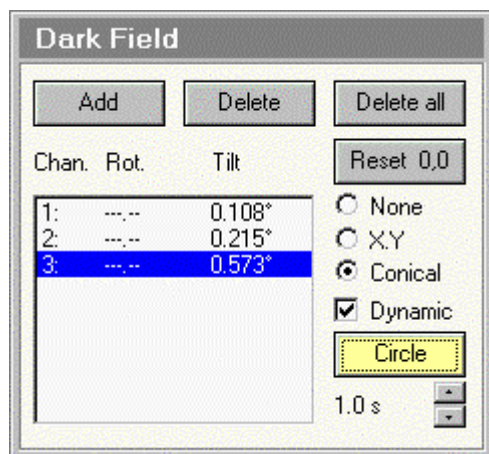

To switch to dynamic conical dark field, first go to static conical dark field (press the Conical radio button). Check the Dynamic checkbox. The system will now have switched from DC to AC coils. Press Circle to start and stop movement.

Dynamic

Switches the microscope from DC to AC (when checked) and back.

Circle

Press Circle to start and stop movement.

Speed

Defines the speed with which the beam drives around in a circle.

4.21 Detector Configuration

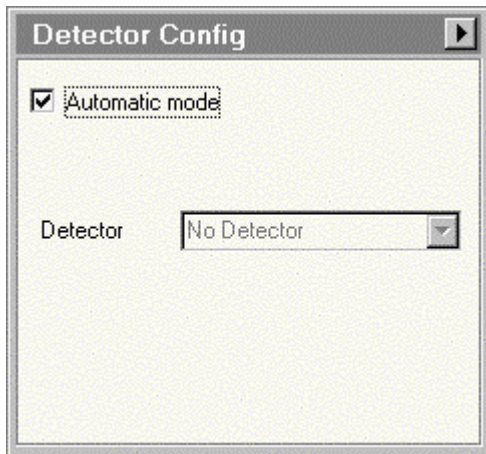

The Detector Configuration Control Panel.

The Detector Configuration Control Panel provides control over the manual or automatic detector shifts executed by the microscope.

Introduction to detector shifts

Underneath the projection chamber, the microscope has three possible mounting positions for detectors:

- On axis
- Near-axis (~3 cm to the WNW) - the position of the STEM Bright-Field / Dark-Field detector assembly.
- Off-axis (~7 cm to the ENE) - a possible position for a TV-rate camera.

When the off-axis positions (near-axis and off-axis) are occupied by detectors, the microscope can shift the image or diffraction pattern automatically to the detector when the viewing screen is raised. The automatic shifts will be executed when the proper detector configuration settings have been set. The actual value of the shifts (which are dependent on the magnification or camera length) are set in alignment procedures.

Note: the detector shift is activated only if the viewing screen is raised.

Automatic mode

When Automatic mode is checked, the off-axis shifts are executed automatically, dependent on the current microscope setup. For example, when STEM is active with the Bright-Field (BF) or Dark-Field (DF) detector as the selected detector, the diffraction pattern will be shifted automatically to the near-axis position when the viewing screen is raised.

Detector selection

When Automatic mode is off (not checked), the choice for the detector selection can be set manually by selecting a detector from the list.

Flap-out

The Flap-out button leads to the Detector Configuration flap-out with the Detector Configuration Options control panel.

When an off-axis TV camera and an on-axis CCD camera are present

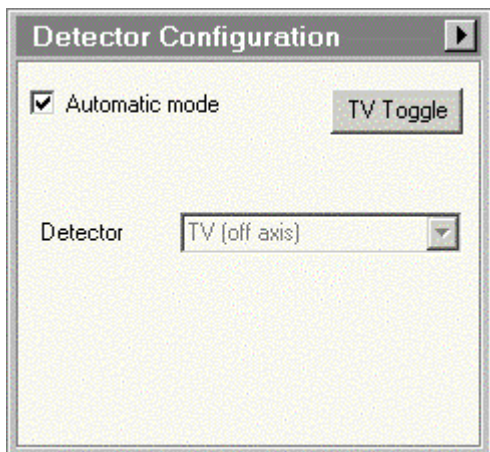

Because the Tecnai microscope cannot predict which of these two cameras you want to use when you lift the screen, a function TV Toggle is provided that allows rapid toggling between the two through a button on the control panel.

The button is present :

- In automatic mode, when the viewing screen is lifted.
- In manual mode, always

4.22 Detector Configuration Options

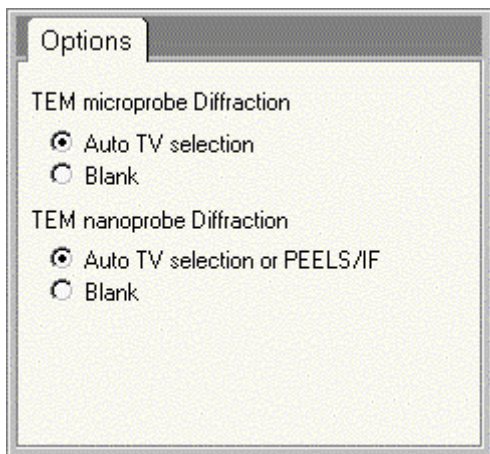

The Detector Configuration Options Control Panel.

The Detector Configuration Options Control Panel allows selection of a number of settings pertinent to the detector configuration. The options control the action of the detector configuration in diffraction when a TV camera is present on the system (Note: this applies to a TV-rate camera without any protection of its own; Slow-scan cameras normally have their own protection that keeps the shutter closed unless an image or diffraction pattern is being acquired). Since diffraction patterns can have very intense beams, there may be some concern with regard to possible damage of the TV scintillator or fiber optic. With the detector configuration options, the user can choose to have the beam blanked automatically when the screen is lifted in diffraction mode.

TEM Microprobe diffraction

The TEM Microprobe diffraction radio buttons choose between Auto TV selection (the diffraction pattern is allowed to fall on the TV camera) and blank (the microscope shutter - below the specimen - is closed).

TEM Nanoprobe diffraction

The TEM Microprobe diffraction radio buttons choose between Auto TV selection or PEELS/IF (the diffraction pattern is allowed to fall on the TV camera or the PEELS or Imaging Filter) and blank (the microscope shutter - below the specimen - is closed).

4.23 Direct alignments

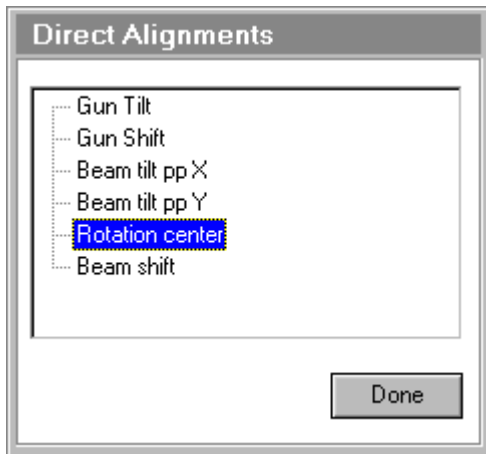

The Direct Alignments Control Panel.

The Direct Alignments Control Panel offers access to the microscope's direct alignments. In addition to the alignment procedures where the operator is taken through a set of alignments in a structured way, the Tecnai microscope provides (rapid) access to a restricted set of direct alignments. In contrast with the procedures, direct alignments do not switch the microscope to predefined states but instead are applicable to the current microscope state. The direct alignments are shown in a list. Which alignments are available depends on the microscope mode.

Alignments can be stored to files and wholly or in part (currently two parts, Column and Gun) restored to the microscope. Alignments for all users are located together and listed in the list of available alignments. The controls for saving and restoring alignments are found in the Alignment File Control Panel.

A few rules:

- You do not change any alignment by activating it. Only when you change a setting with the Multifunction knobs, do you change alignments. Changes become operational immediately. They are stored when the alignment is exited (Done).
- Activate a direct alignment by clicking on the title of the first subprocedure (or the individual subprocedure required if not the whole procedure is needed). Stop an alignment by pressing Done. Going to another tab (where the Direct Alignment Control Panel is no longer visible) also exits the alignment.
- Direct alignments may differ depending on the level of user, with experts and supervisor levels having more alignments accessible than users.
- All direct alignments have on-line help pages that describe the purpose and operation of the particular alignment. Press F1 while a direct alignment is active and the proper page should come up.
- You can move to another control panel as long as you stay within the current tab (you can also pop-up panels on the lower right), but if you move to another tab, then the alignment is exited.

Direct alignment selection

Selection is done in the list of alignments. Click on a direct alignment to activate it.

Done

Switches alignment off.

4.24 EDX

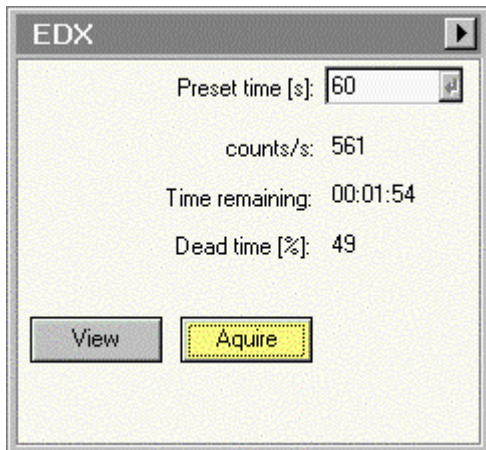

The EDX Control Panel.

In the EDX Control Panel the controls for (single) EDX spectrum acquisition are located.

Preset time

The Preset time sets the acquisition time for the currently active acquisition mode (View, Acquire).

Count/s

During acquisition the count rate (in counts per second) is displayed.

Time remaining

During acquisition the time remaining before acquisition is finished is displayed.

Dead time

During acquisition the detector dead time is displayed. At high dead times the background of the label becomes red, otherwise it is green.

View

Pressing the View button:

- When the button is gray, switches the EDX acquisition settings to those of the View mode and starts acquisition.
- When the button is yellow, pauses EDX acquisition.
- When the button is white, resumes EDX acquisition (but starting with a new spectrum) if possible. If the start command could not be given to TIA, the button will remain white.

By definition View is continuous acquisition.

Acquire

Pressing the Acquire button:

- When the button is gray, switches the EDX acquisition settings to those of the Acquire mode and starts acquisition.
- When the button is yellow, stops EDX acquisition.
- When the button is white, resumes EDX acquisition (but starting with a new spectrum) if possible. If the start command could not be given to TIA, the button will remain white.

By definition Acquire is single acquisition.

Flap-out

Pressing the arrow button displays the flap-out with the EDX Settings Control Panel.

4.25 EDX settings

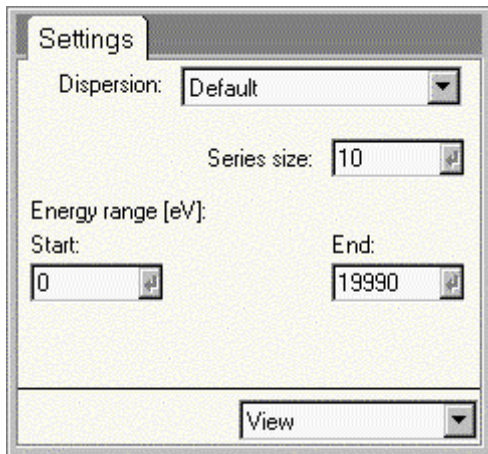

The EDX Settings Control Panel.

In the EDX Settings Control Panel the EDX acquisition parameters are defined.

Dispersion

The drop-down list contains the accessible dispersion settings for the EDX detector (depend on the type of EDX detector present). This list corresponds to the list of the More EDX Dispersions tab in TIA.

Series size

Under series size the size of the acquisition series for the currently active acquisition mode is set.

Energy range

The Start and End values define the start and end energy (in electronvolt) of the spectrum.

Acquisition mode

In the acquisition mode drop-down list, the acquisition mode for which the parameters must be defined, can be selected. The difference between selecting the acquisition mode through the drop-down list and by pressing the equivalent button in the main control panel is that the drop-list selection selects the mode but does not automatically start acquisition.

4.26 Experiments

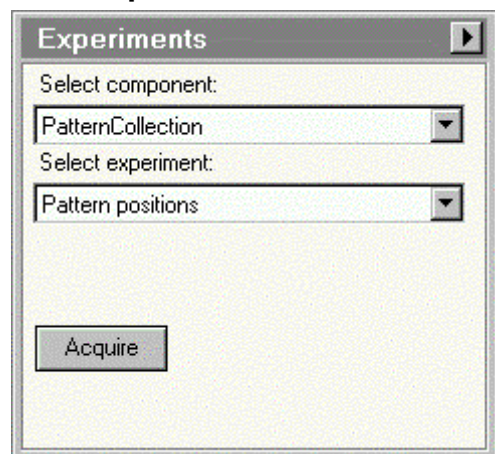

The Experiments Control Panel.

In the Experiments Control Panel multiple-Experiments experiments are controlled. Currently these experiments cover :

- Multi-point spectrum acquisition
- Spectrum-profile acquisition
- Spectrum-image acquisition
- Drift-corrected spectrum time series (a series of spectra collected at a single position)
- Drift-corrected multi-point spectrum acquisition
- Drift-corrected spectrum-profile acquisition
- Drift-corrected spectrum-image acquisition
- Multi-point CCD diffraction-pattern acquisition
- CCD diffraction-pattern-profile acquisition
- CCD diffraction-pattern-image acquisition

The spectrum-acquisition experiments can be without or with drift correction.

All settings for the experiments are defined in the Settings control panel.

Note: Before an experiment can be started, the required displays must already be present (see further below).

For additional information, please also refer to:

- TIA basics
- TIA STEM image acquisition
- TIA EDX spectrum acquisition
- TIA EELS spectrum acquisition
- TIA CCD image acquisition

Components

The drop-down list allows selection of a type of experiment component (spectrum or CCD diffraction-pattern acquisition).

Experiments

The drop-down list allows selection of a type of experiment.

Acquire

Pressing the Acquire button :

- When the button is gray, start the spectrum acquisition.
- When the button is yellow, stops the spectrum acquisition.

Flap-out

Pressing the flap-out button leads to the flap-out with the Settings, and Loader control panels.

4.27 Spectrum acquisition

The spectrum acquisition experiments allow automatic recording of EDX and EELS spectra, STEM images and diffraction patterns (CBED patterns since the microscope will be in STEM mode) at a single position in a time series, at user-defined positions (multi-point), along a profile or regularly spaced in an "image" (a two-dimensional array of patterns).

In order to acquire the data, the following must be present in TIA:

- A STEM image display (generate by recording a STEM image).
- A display for each of the type of data to be collected (generate by collecting the particular data once through their own control panels).
- A marker or set of markers suitable for the experiment, one beam position for time series, multiple beam position markers for multipoint, a line marker for profile and an image-selection marker for image. In case of a line or image-selection marker, the marker must be selected (click on it and it will be marked by white squares at the end points). For drift correction there must be a (not-selected) image-selection marker that defines the drift-correction area.

4.27.1 Multi-point spectrum acquisition

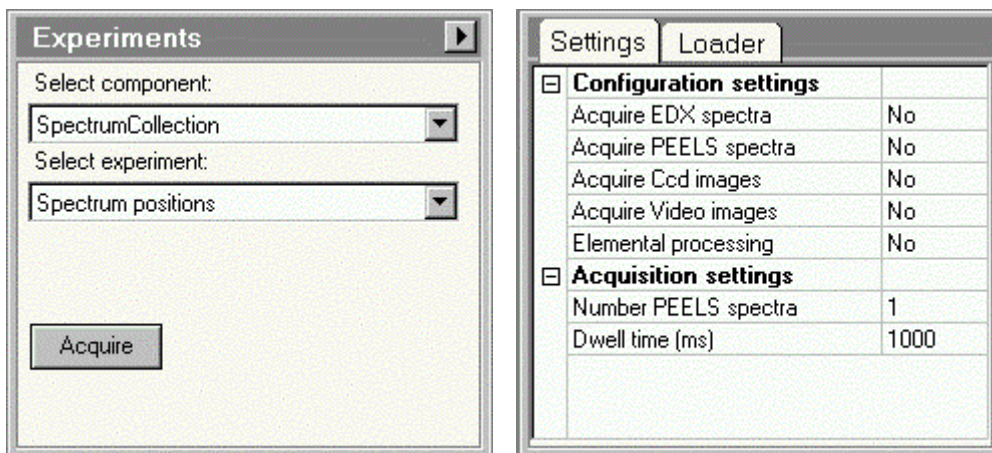

Configuration settings

Under configuration settings is defined which detector(s) will be used for the acquisition and whether elemental processing is done or not. When elemental processing is on and the proper energy-range selection markers are put into the spectrum display, the experiment will generate the data (profile, images) during acquisition.

Note: Some acquisition settings are mutually exclusive because they make use of detectors that are located at different physical location, where one detector (e.g. a CCD) blocks the view of the other (e.g. PEELS) or a detector is used for more than one type of data and only one can be selected at a time (e.g. an Imaging Filter CCD to acquire diffraction patterns as well as PEELS spectra). Excluded detectors are shown disabled (grayed).

Acquisition settings

Under acquisition settings is defined the dwell time of each acquisition. For PEELS data acquisition you can define how many spectra are to be acquired within the dwell time set (these spectra are added together).

4.27.2 Spectrum-profile acquisition

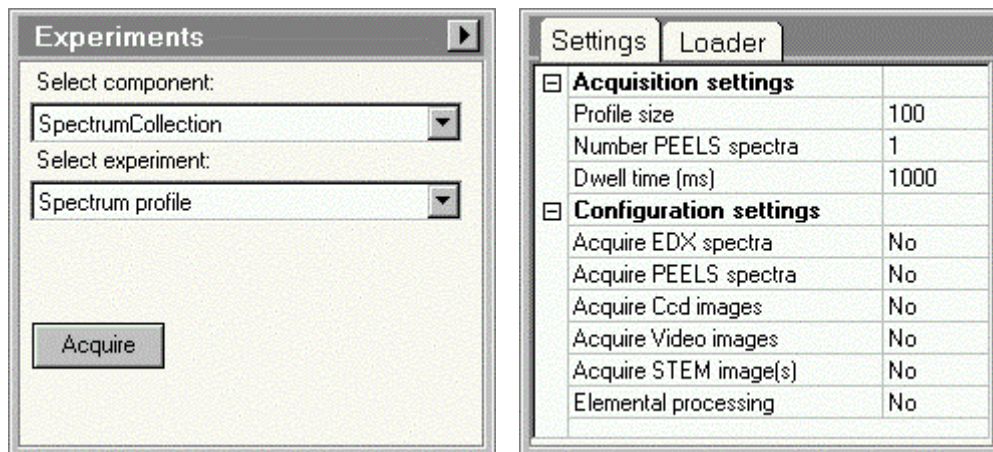

The Acquisition settings are as defined for the multi-point spectrum acquisition experiment except for the added setting for the Profile size which gives the number of points along the profile line.

4.27.3 Spectrum-image acquisition

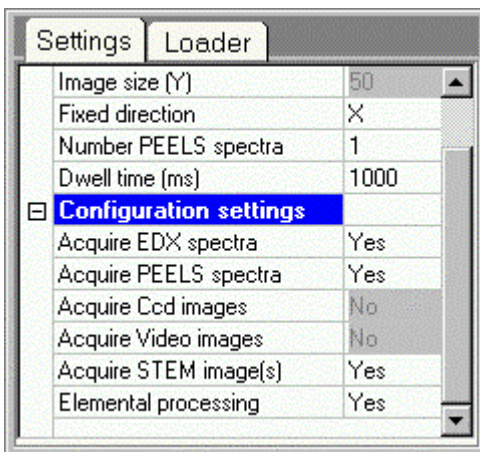
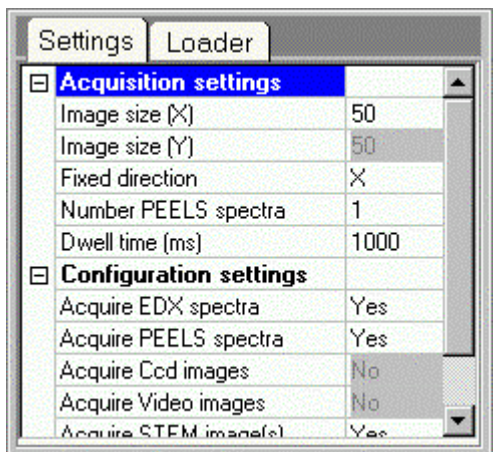
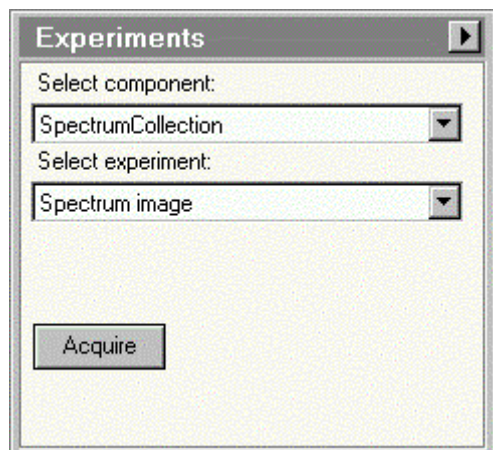

The Acquisition settings are as defined for the multi-point spectrum acquisition experiment except for the added settings for the Image size and Fixed direction. The number of points is defined by the Image size parameter as well as the ratio of the dimensions of the image-selection marker.

Note: The spacing between the acquisition positions is identical in both (X and Y) directions. Therefore the number of points is totally defined by the number of points in one direction as well as the size of the image-selection marker. Only one of the Image size parameters is adjustable (the Fixed direction defines which), the other size is automatically adjusted by the experiment (but the value indicated in the Settings control panel is not necessarily the correct one; the value is set at the beginning of the acquisition). For example, assume the image-selection marker has a horizontal size of 100 and a vertical size of 20 (arbitrary units). You define a Fixed direction X with 10 points, then the Y direction will be $20/100 \cdot 10 = 2$ points, so the array of points will be 10x2. If you defined the Y direction as fixed with 10 points, the X direction would give $100/20 \cdot 10 = 50$ points so the array would be 50x10 points.

4.27.4 Drift-corrected spectrum time series acquisition

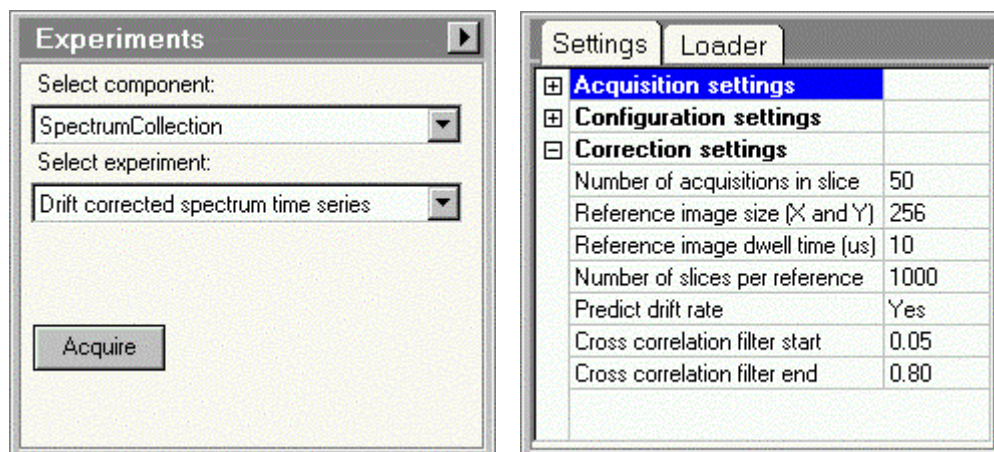

The Acquisition settings are as defined for the other spectrum acquisition experiments. Drift correction is done on the basis of an area marked in the starting image by an image-selection marker. The area marked should contain a suitable feature for cross-correlation to allow drift to be measured.

The meaning of the (drift) Correction settings is as follows

Number of acquisitions in slice

A slice is the period between successive checks of the drift, so the number of acquisitions in the slice is the number of data acquisitions done before a new drift check is done.

Reference image size

The size in pixels of the reference image.

Reference image dwell time

The dwell time used for (STEM) acquisition of the reference image.

Slices/reference

The slices per reference parameter defines the number of drift correction measurement cycles after which the drift correction data base is reset (it is always reset as well at the start of an experiment).

Predict drift rate

When the Predict drift rate is selected, the drift correction will apply a drift correction to individual spectra within a drift correction slice on the basis of the historically measured drift rate (otherwise the drift correction is applied once per slice).

Cross-correlation filter

The start and end parameters of the cross-correlation filter define two settings used to filter the drift-correction images. The filtering is used to make drift measurement more reliable. The filter is a band-pass filter that removes the low and high frequencies from the image. Cutting off the low frequencies is important because they do not contribute to accurate drift measurements (the distances they represent are too large) and they can lead to erroneous cross-correlation peak measurements. The high frequencies are generally dominated by noise and thus only cause imprecision in the drift measurement. In general the settings are only important for noisy images, where some adjustment may be necessary for drift measurement to work. If (in exceptional cases) there is only low-frequency contrast (e.g. only a single grain boundary visible), it may be necessary to adjust the Start parameter down.

4.27.5 Drift-corrected multi-point spectrum acquisition

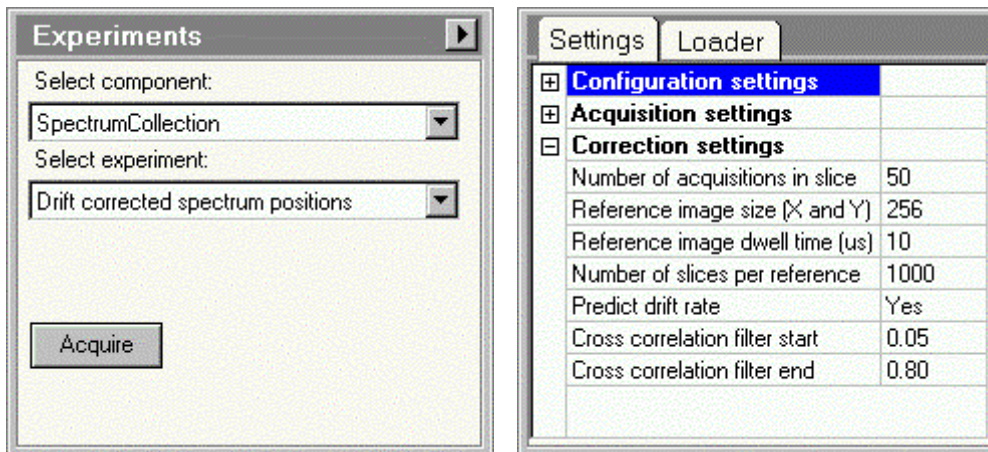

The Configuration and Acquisition settings are as described for the Multi-point spectrum acquisition experiment, while the (drift) Correction settings are as described for the drift-corrected time series experiment.

4.27.6 Drift-corrected spectrum-profile acquisition

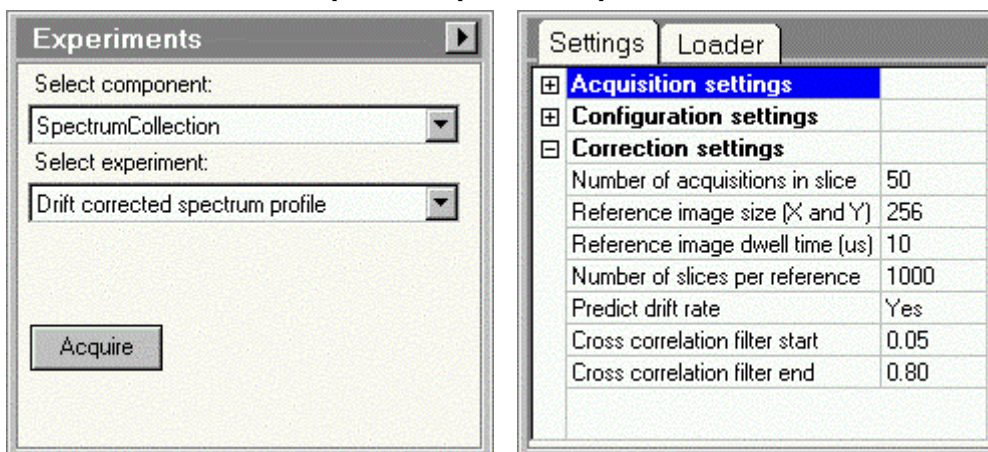

The Configuration and Acquisition settings are as described for the Spectrum-profile acquisition experiment, while the (drift) Correction settings are as described described for the drift-corrected time series experiment.

4.27.7 Drift-corrected spectrum-image acquisition

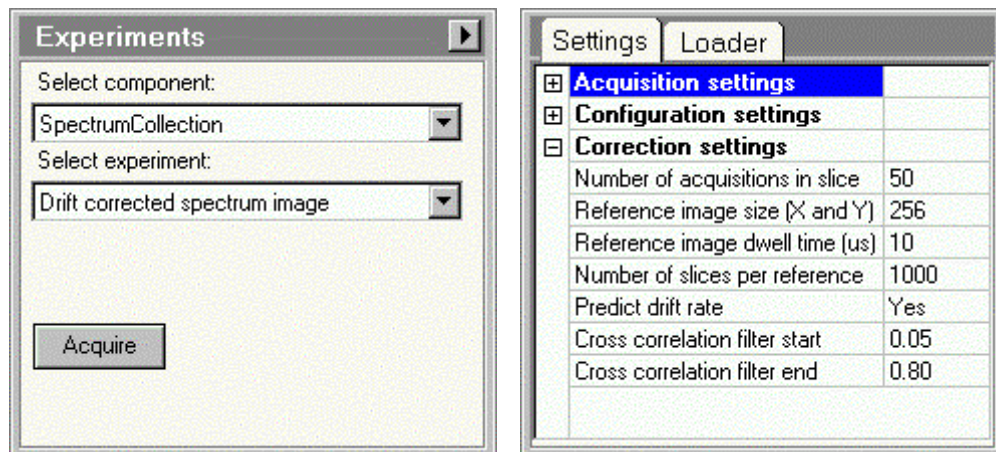

The Configuration and Acquisition settings are as described for the Spectrum-image acquisition experiment, while the (drift) Correction settings are as described for the drift-corrected time series experiment. For this experiment there must be two image-selection markers present. The marker selected contains the area where the data will be collected, the other marker contains the drift-correction area.

4.28 CCD diffraction-pattern acquisition

The CCD diffraction-pattern acquisition experiments allow automatic recording of diffraction patterns (CBED patterns since the microscope will be in STEM mode) at user-defined positions (multi-point), along a profile or regularly spaced in an "image" (a two-dimensional array of patterns).

In order to acquire the data, the following must be present in TIA:

- A STEM image display (generate by recording a STEM image).
- A CCD "image" display (generate by recording a CCD image).
- A marker or set of markers suitable for the experiment, beam position markers for multipoint, a line marker for profile and an image-selection marker for image. In case of a line or image-selection marker, the marker must be selected (click on it and it will be marked by white squares at the end points).

4.28.1 Multi-point CCD diffraction-pattern acquisition

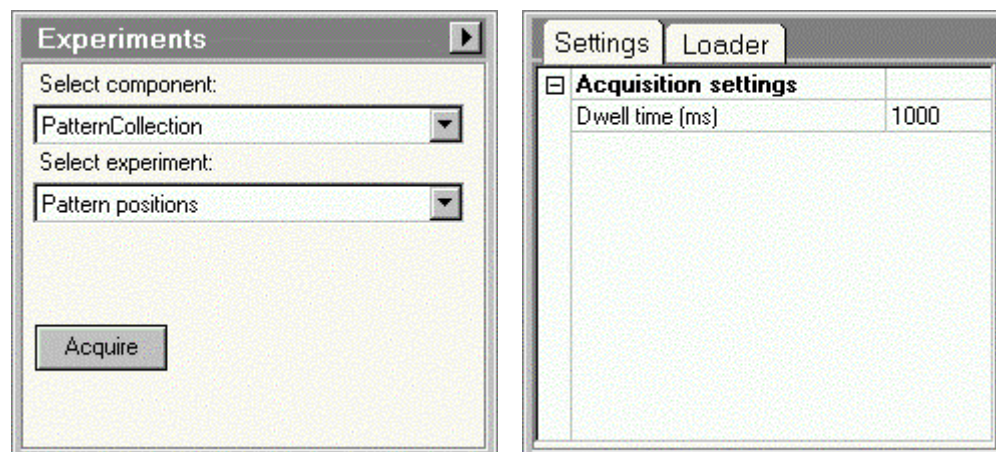

Diffraction patterns will be acquired for each STEM image point defined by a beam-position marker. The sequence of collection is as defined by the sequence of the markers. The only setting for this experiment is the Dwell time (CCD acquisition time).

4.28.2 CCD diffraction-pattern-profile acquisition

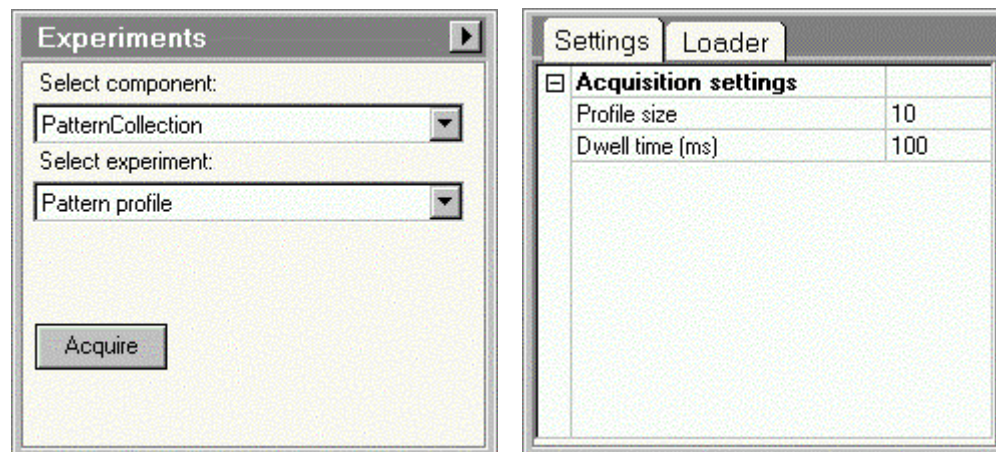

Diffraction patterns will be acquired along the give profile line for the number of points as defined by the Profile size parameter. The settings for this experiment are the Profile size and the Dwell time (CCD acquisition time).

4.28.3 CCD diffraction-pattern-image acquisition

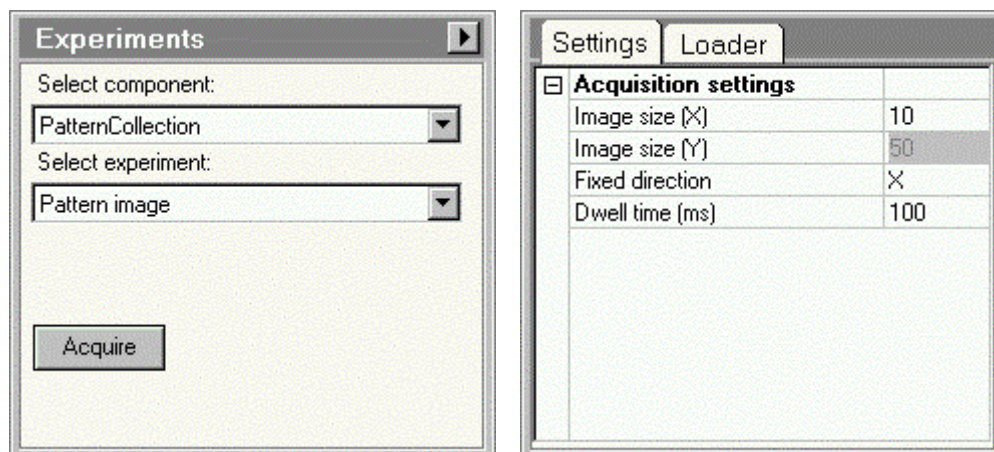

Diffraction patterns will be acquired in the give image selection. The number of points is defined by the Image size parameter as well as the ratio of the dimensions of the image-selection marker. The settings for this experiment are the Image size X and Y (number of points), the Fixed direction and the Dwell time (CCD acquisition time).

Note: The spacing between the diffraction-pattern collection positions is identical in both (X and Y) directions. Therefore the number of points is totally defined by the number of points in one direction as well as the size of the image-selection marker. Only one of the Image size parameters is adjustable (the Fixed direction defines which), the other size is automatically adjusted by the experiment (but the value indicated in the Settings control panel is not necessarily the correct one; the value is set at the beginning of the acquisition).

For example, assume the image-selection marker has a horizontal size of 100 and a vertical size of 20 (arbitrary units). You define a Fixed direction X with 10 points, then the Y direction will be $20/100 \cdot 10 = 2$ points, so the array of patterns will be 10x2. If you defined the Y direction as fixed with 10 points, the X direction would give $100/20 \cdot 10 = 50$ points so the array would be 50x10 patterns.

4.29 Experiments Settings

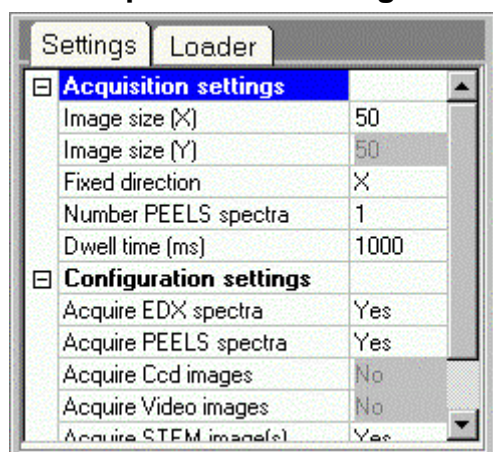

The Experiments Settings Control Panel.

In the Experiments Settings Control Panel the acquisition parameters for the experiment are defined. The settings are displayed in a so-called property editor. This is a two-column grid, listing the setting on the left-hand side and its value on the right-hand side. You can change the settings by clicking on the value. Sometimes you have to type in a number or other setting. In the case where a limited selection is

possible (for example with Yes or No) a small down arrow on the right-side allows selection of the one of the possibilities. Setting changes are updated as soon as you move to another setting value (e.g. by pressing the down or up arrow). Settings are grouped under headers (like Acquisition settings). You can open or close a group by clicking on the + or - sign to the left of the group name. Settings that are grayed out are disabled under the current combination of settings selected.

For an overview of the settings per experiment, see the description of the experiments on the Experiments Control Panel page.

4.30 Experiments Loader

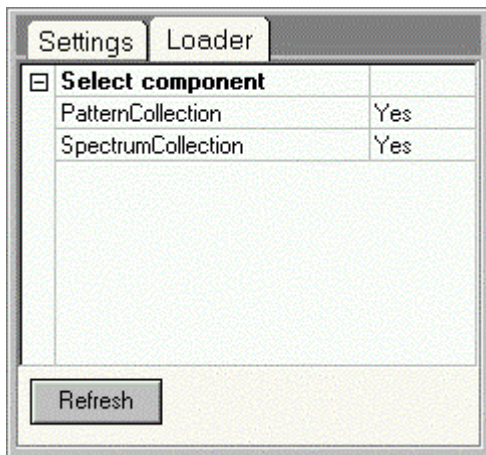

The Experiments Loader Control Panel.

In the Experiments Loader Control Panel is defined which experiment groups are loaded.

Experiments selection

The experiments selection list defines which experiments are loaded or unloaded.

Refresh

When the Refresh button is pressed, the experiments are reloaded.

4.31 Filament (User)

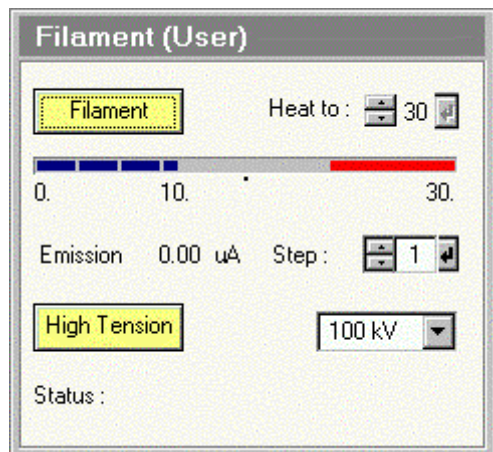

The Filament Control Panel.

The Filament Control Panel displays settings and allows control over the filament (W/LaB₆) and high tension settings.

Filament

The Filament button switches the heating of the filament on or off. The filament button has three possible settings:

- The filament is enabled but off : the button is 'normal' grey. The Heat to step value must be other than 0 (otherwise pressing the button has no effect).
- The filament is on : the button is yellow.
- The filament is disabled : the text in the button is grey. This typically occurs when the vacuum is not ready or the high tension is off.

When the filament heating is switched on, the filament is heated to the value indicated in the Heat to: spin-enter-edit control at a rate defined by the delay steps.

Heat to

The Heat to spin buttons change the filament heating step to which the filament will be heated. If the filament is off (Filament button is gray), any changes have no direct effect. If the filament is on (button yellow), the changes (defined by the spin buttons) are implemented once the Enter button has been pressed.

Changes in heating current are executed with the delay steps defined.

The Heat to value cannot exceed the filament limit set.

Heating step display

A progress bar displays the current value of the heating as a fraction of the total range. The total range is determined by the filament limit setting.

Emission step

The Emission Step spin buttons change the emission settings of the gun. Press the Enter button to set the new value. Possible values are in the range 1 to 6. In general, the emission should be set so as not to exceed normal filament emission values (typically 10 μ A for LaB₆, 50 μ A for W).

At lower high tension values, the emission value must be increased to keep the emission current similar to the values obtained at higher high tension settings.

Emission display

The emission display shows the current value of the emission current.

High tension

Pressing the High tension button switches the high tension on and off. The high-tension setting is the one shown in the drop-down list box on the right. The High tension button has three possible settings:

- The high tension is enabled but off : the button is 'normal' grey.
- The high tension is on : the button is yellow.
- The high tension is disabled : the text in the button is grey.

The high tension is enabled through the High tension enable button on the System On/Off Panel.

High tension setting

The high tension setting is by clicking in the drop-down list box and selecting the required setting (a range of fixed settings, comprising 20, 40, 60, 80, 100 and 120 kV).

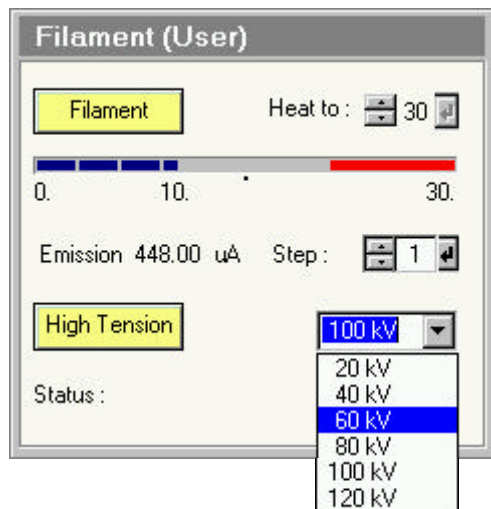

Status

The status displays (when relevant) waiting time before the filament has reached the status requested by the operator.

4.32 Filament (Expert)

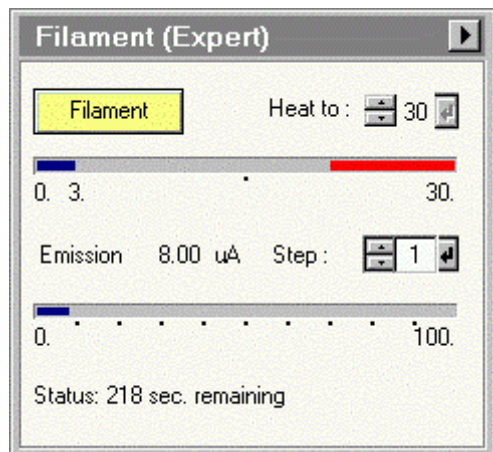

The Filament Control Panel.

The Filament control panel displays settings and allows control over the filament (W/LaB₆).

Filament

The Filament button switches the heating of the filament on or off. The filament button has three possible settings:

- The filament is enabled but off : the button is 'normal' grey. The Heat to step value must be other than 0 (otherwise pressing the button has no effect).
- The filament is on : the button is yellow.
- The filament is disabled : the text in the button is grey. This typically occurs when the vacuum is not ready or the high tension is off.

When the filament heating is switched on, the filament is heated to the value indicated in the Heat to: spin-enter-edit control at a rate defined by the delay steps.

Heat to

The Heat to spin buttons change the filament heating step to which the filament will be heated. If the filament is off (Filament button is gray), any changes have no direct effect. If the filament is on (button yellow), the changes (defined by the spin buttons) are implemented once the Enter button has been pressed.

Changes in heating current are executed with the delay steps defined.

The Heat to value cannot exceed the filament limit set.

Heating step display

A progress bar displays the current value of the heating as a fraction of the total range. The total range is determined by the filament limit setting.

Emission step

The Emission Step spin buttons change the emission settings of the gun. Press the Enter button to set the new value. Possible values are in the range 1 to 6. In general, the emission should be set so as not to exceed normal filament emission values (typically 10 uA for LaB₆, 50 uA for W).

At lower high tension values, the emission value must be increased to keep the emission current similar to the values obtained at higher high tension settings.

Emission display

A progress bar displays the current value of the emission current. The total range displayed is one of a series of values (10, 25, 100) that are dynamically set, depending on the value of the emission current itself.

Status

The status displays (when relevant) waiting time before the filament has reached the status requested by the operator.

Filament Flap-out

Pressing the arrow button displays the flap-out containing the Filament Settings control panel.

Setting the filament saturation

Thermionic filaments have a specific saturation setting. If a filament is run at a lower heating current, the emission typically will be somewhat unstable (as well as lower). If a filament is run oversaturated it will not emit more electrons but the lifetime of the filament will be decreased because filament tip evaporation increases with filament heating temperature. It is important therefore to set the filament to its proper saturation setting.

There are several ways to judge whether a filament is saturated or not:

1. Observe the emission of the filament as the heating is increased

As the heating current of a filament is increased, the emission will increase until a maximum is reached. At higher heating currents the current will stay roughly the same or even drop a little. Turn down the heating current until the emission starts falling appreciably (>10% per step). Set the filament limit to the value just above the step where the current started falling strongly.

2. Observe the emission pattern of the filament

As the heating current is increased, the image of the filament (make sure the beam is focussed and visible on the viewing screen) changes. Typically at low values some emission is seen. Then, as the heating is increased, the emission appears to come from a ring with a dark center. With further increase of the filament heating current, the dark center becomes smaller and, at filament saturation, disappears.

With tungsten filaments, the structure in the focussed beam normally disappears totally.

With LaB₆ filaments, very often the structure doesn't disappear totally. LaB₆ filaments get damaged by evaporation of the lanthanum-hexaboride into the vacuum, leaving pits and grooves that remain visible. One shouldn't overheat the filament to try and remove this structure (the structure will disappear when the beam is defocussed so it doesn't interfere with microscopy).

Note: an overheated filament may result in an instability in the high tension (looking like a ripple of ~5 volts) because the bias feedback cannot work properly anymore.

Emission: a technical explanation

The emission parameter influences the bias voltage on the Wehnelt of the thermionic gun. If the bias voltage is high (which corresponds to a low emission setting), the electrons can only be extracted from the tip of the filament. When the bias voltage is lowered (at higher emission settings), the electrons are extracted from larger and larger areas (higher up) of the filament.

Decreasing the bias voltage increases the total emission current, but at the same time the area of the filament that is emitting (and therefore usually also the effective source size) is increasing. The higher emission typically also results in a stronger Boersch effect (Coulomb interactions between electrons) in the first cross-over below the filament (the 'source') which increases the energy spread of the electron beam.

4.33 Filament Settings (Expert)

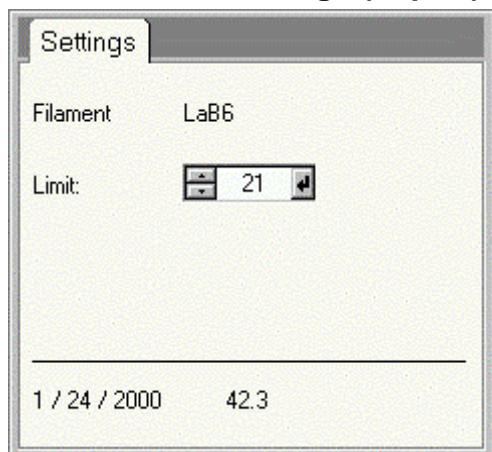

The Filament Settings Control Panel.

The Filament Settings Control Panel contains a number of system settings concerning the filament. Users have no access to this panel. Experts can only adjust the filament limit and inspect the values for the settings. All other functions are accessible only to the supervisor.

Filament limit

The filament limit is the value up to which the filament setting can be increased before it stops automatically. The value can be adjusted by expert user and supervisor.

Filament type

The filament type can either be W (tungsten) or LaB₆. The type of filament can only be chosen by the supervisor.

Filament hour counter

The filament hour counter displays the date the filament was installed and the number of hours the filament has been in operation.

4.34 Filament (Supervisor)

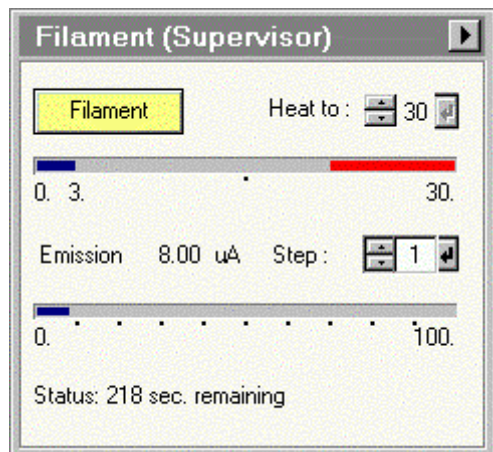

The Filament control panel.

The Filament control panel displays settings and allows control over the filament (W/LaB₆).

Filament

The Filament button switches the heating of the filament on or off. The filament button has three possible settings:

- The filament is enabled but off : the button is 'normal' grey. The Heat to step value must be other than 0 (otherwise pressing the button has no effect).
- The filament is on : the button is yellow.
- The filament is disabled : the text in the button is grey. This typically occurs when the vacuum is not ready or the high tension is off.

When the filament heating is switched on, the filament is heated to the value indicated in the Heat to: spin-enter-edit control at a rate defined by the delay steps.

Heat to

The Heat to spin buttons change the filament heating step to which the filament will be heated. If the filament is off (Filament button is gray), any changes have no direct effect. If the filament is on (button yellow), the changes (defined by the spin buttons) are implemented once the Enter button has been pressed.

Changes in heating current are executed with the delay steps defined.

The Heat to value cannot exceed the filament limit set.

Heating step display

A progress bar displays the current value of the heating as a fraction of the total range. The total range is determined by the filament limit setting.

Emission step

The Emission Step spin buttons change the emission settings of the gun. Press the Enter button to set the new value. Possible values are in the range 1 to 6. In general, the emission should be set so as not to exceed normal filament emission values (typically 10 μ A for LaB₆, 50 μ A for W).

At lower high tension values, the emission value must be increased to keep the emission current similar to the values obtained at higher high tension settings.

Emission display

A progress bar displays the current value of the emission current. The total range displayed is one of a series of values (10, 25, 100) that are dynamically set, depending on the value of the emission current itself.

Status

The status displays (when relevant) waiting time before the filament has reached the status requested by the operator.

Filament Flap-out

Pressing the arrow button displays the flap-out containing the Filament Settings control panel.

Setting the filament saturation

Thermionic filaments have a specific saturation setting. If a filament is run at a lower heating current, the emission typically will be somewhat unstable (as well as lower). If a filament is run oversaturated it will not emit more electrons but the lifetime of the filament will be decreased because filament tip evaporation increases with filament heating temperature. It is important therefore to set the filament to its proper saturation setting.

There are several ways to judge whether a filament is saturated or not :

1. Observe the emission of the filament as the heating is increased

As the heating current of a filament is increased, the emission will increase until a maximum is reached. At higher heating currents the current will stay roughly the same or even drop a little. Turn down the heating current until the emission starts falling appreciably (>10% per step). Set the filament limit to the value just above the step where the current started falling strongly.

2. Observe the emission pattern of the filament

As the heating current is increased, the image of the filament (make sure the beam is focussed and visible on the viewing screen) changes. Typically at low values some emission is seen. Then, as the heating is increased, the emission appears to come from a ring with a dark center. With further increase of the filament heating current, the dark center becomes smaller and, at filament saturation, disappears.

With tungsten filaments, the structure in the focussed beam normally disappears totally.

With LaB₆ filaments, very often the structure doesn't disappear totally. LaB₆ filaments get damaged by evaporation of the lanthanum-hexaboride into the vacuum, leaving pits and grooves that remain visible. One shouldn't overheat the filament to try and remove this structure (the structure will disappear when the beam is defocussed so it doesn't interfere with microscopy).

Note: an overheated filament may result in an instability in the high tension (looking like a ripple of ~5 volts) because the bias feedback cannot work properly anymore.

Emission: a technical explanation

The emission parameter influences the bias voltage on the Wehnelt of the thermionic gun. If the bias voltage is high (which corresponds to a low emission setting), the electrons can only be extracted from the tip of the filament. When the bias voltage is lowered (at higher emission settings), the electrons are extracted from larger and larger areas (higher up) of the filament.

Decreasing the bias voltage increases the total emission current, but at the same time the area of the filament that is emitting (and therefore usually also the effective source size) is increasing. The higher emission typically also results in a stronger Boersch effect (Coulomb interactions between electrons) in the first cross-over below the filament (the 'source') which increases the energy spread of the electron beam.

4.35 Filament Settings (Supervisor)

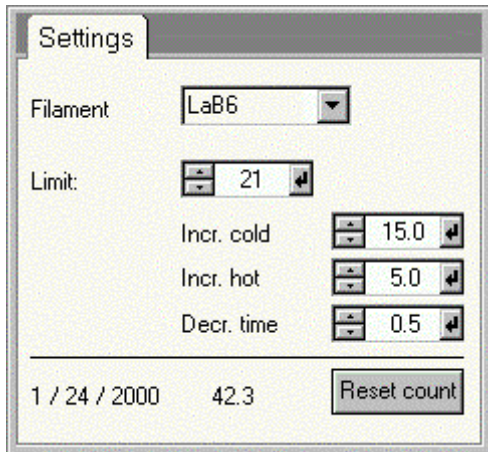

The Filament Settings control panel.

The Filament Settings control panel contains a number of system settings concerning the filament. Users have no access to this panel. Experts can only adjust the filament limit and inspect the values for the settings. All other functions are accessible only to the supervisor.

Filament type

The filament type can either be W (tungsten) or LaB₆ (CeB₆ can be treated as equal to LaB₆). The instrument has two sets of values for controlling the filament. These are exchanged when the other filament type is chosen. The type of filament can only be chosen by the supervisor.

Filament limit

The filament limit is the value up to which the filament setting can be increased before it stops automatically. The value can be adjusted by expert user and supervisor. Users have no access to this value. Instead their filament is defined as the limit set by the supervisor.

Increase heating time cold

In order to safeguard filaments against destructive thermal stresses, a delay per step is built in to the filament heating procedure. The cold increase time refers to the time taken for each step after the gun has been opened. The value can only be adjusted by the supervisor. Normal values are 0.2 seconds for W and 15 seconds for LaB₆.

Increase heating time hot

In order to safeguard filaments against destructive thermal stresses, a delay per step is built in to the filament heating procedure. The hot increase time refers to the time taken for each step in normal operation (the filament has been heated at least once before). The value can only be adjusted by the supervisor. Normal values are 0.1 seconds for W and 5 seconds for LaB₆.

Decrease heating time

In order to safeguard filaments against destructive thermal stresses, a delay per step is built in to the filament heating procedure. The decrease time refers to the time taken for each step when the filament setting is lowered. The value can only be adjusted by the supervisor. Normal values are 0.1 seconds for W and 0.5 seconds for LaB₆.

Counter display

The Tecnai microscope is equipped with a filament hour counter. The counter displays the date the filament was installed and the number of hours the filament has been in operation.

Reset count

Pressing the Reset count button resets the filament counter to zero (that is, the date becomes today and the hour counter becomes zero). This function is only accessible to the supervisor. Pressing the Reset count button should be done after the filament has been exchanged.

4.36 High Tension (Expert/Supervisor)

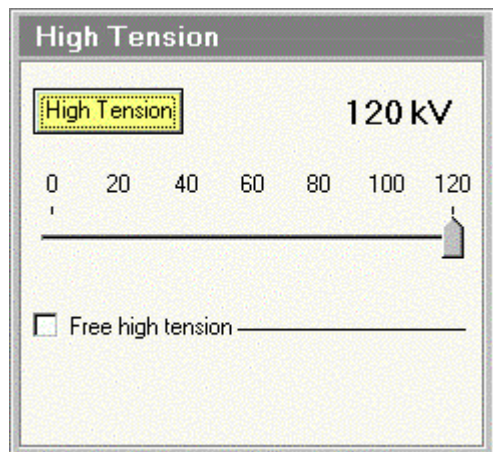

The High Tension Control Panel.

The High Tension Control Panel provides control over the high tension and its setting.

High tension

Pressing the High tension button switches the high tension on and off. The high-tension setting is displayed on the right. The High tension button has three possible settings:

- The high tension is enabled but off: the button is 'normal' gray.
- The high tension is on: the button is yellow.
- The high tension is disabled: the text in the button is gray.

The high tension is enabled through the High tension enable button on the System On/Off Panel.

Display value

The high tension display value shows the current high-tension setting. (Note that this is not a measured value.) If the high tension is on the fixed steps, the value is displayed as integer, otherwise (in Free high tension control) it is displayed with three decimals.

High tension setting

The high tension setting is selected by dragging the marker on the high-tension trackbar to the required setting (a range of fixed settings, comprising 20, 40, 60, 80, 100 and 120 kV). Settings other than the fixed high tension steps are available through the Free high tension control.

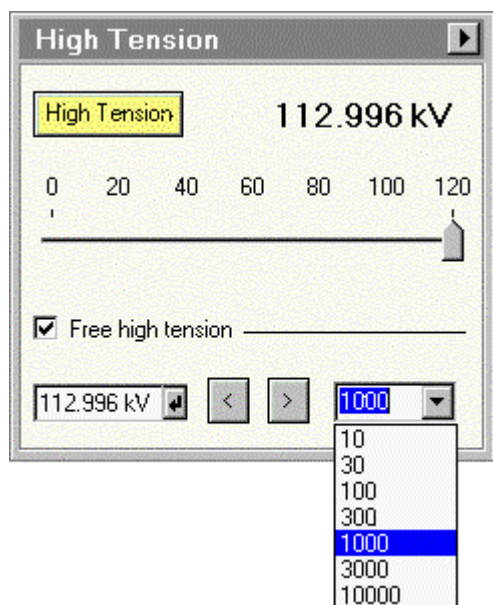

Free high tension

Through the Free high tension control any high-tension setting between 0 and 120 kV can be set with a minimum step size of 10 volts. (Note that at very low high-tension settings below 20 kV the high tension may effectively switch off.) To go to Free high tension control, click on the Free high tension check box. The Control panel will change to the following:

Free high tension value

The Free high tension value is set by changing the number in the edit control. The value set by the microscope will be as close as possible to the value indicated (within the limitations given by the smallest hardware step for the high tension). The high tension is changed only when the Enter button is pressed. The default units expected are in kiloVolts. You can also use Volts but then you have to add the unit for the value typed (V or Volts).

< >

Pressing the <> button instructs the microscope to change the Free high-tension value by the step size indicated.

Free high-tension step

The Free high-tension steps (used by the < > buttons) can be selected from the step drop-down list.

When the Free high tension is switched off (by clicking on the check box again), the high tension will go the nearest fixed high tension step that is lower or equal to the Free high tension step (so, for example, on a Tecnai 20 80 kV free goes to 80 kV fixed, but 59.340 kV free goes to 40 kV fixed).

4.37 Image Settings

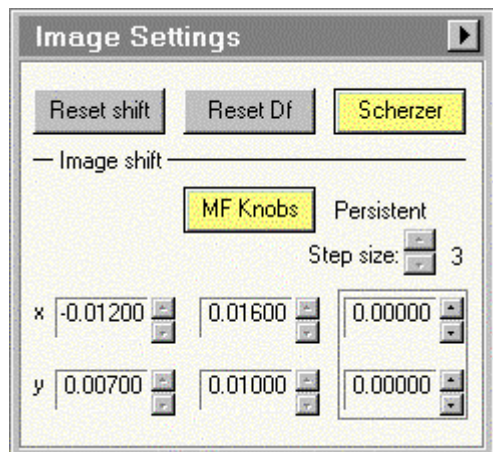

The Image Settings Control Panel.

The Image Settings Control Panel contains two sets of controls, general image settings control and the image shift settings.

Flap-out

Pressing the flap-out button displays the flap-out containing the Focus control panel.

4.37.1 Image settings

Reset shift

Pressing the reset shift button reset all relevant shifts. In imaging this applies to any user-defined image shift (user shift and coupled image-beam shift, see below). In diffraction, the diffraction shift is reset.

Reset Df

Pressing the Reset Df button resets the defocus display value to 0 (the objective or diffraction-lens current itself is not changed).

Scherzer/Contrast

Pressing the Scherzer/Contrast button activates/deactivates the Scherzer or Contrast functions. Which function is used is defined in the Focus control panel of the flap-out. A description of the functions is given below.

Note: The Scherzer/Contrast functions are available only in HM. In other modes the button will be disabled. If you switch from HM with Scherzer or Contrast on to another mode, the button becomes disabled but stays yellow (to indicate that the function is still on in HM; functionally it doesn't anything in the other mode). You can only switch the function off by going back to HM.

Scherzer function

The Scherzer function provides a means for quickly switching to the Scherzer focus and back. Scherzer focus is a focus setting often used in high-resolution imaging. It is the focus where the largest number of diffracted beams have the same phase and therefore the image in thin parts of the specimen will look similar to a projection of the structure.

There are three focus settings on the microscope that are important for high-resolution imaging: Gaussian (absolute) focus, minimum-contrast focus and Scherzer focus.

Gaussian focus	0 nm
Minimum-contrast focus	$\sim 0.4 * \text{Scherzer}$
Scherzer focus	$-1.2 * (Cs * \lambda)^{0.5}$

Note: Because some people use a different definition of Scherzer focus (a constant different from 1.2 as used here), for example 1.0 or 1.1, it is possible to change the constant in the Focus control panel.

Of the three focus settings only minimum contrast is recognisable at high magnifications and is therefore the only one that can be used as a reference point. However, it should be realised that the uncertainty in the setting of minimum contrast focus is about 5 to 10 nm.

The Scherzer function should only be activated when the image is at minimum contrast. The microscope will reset the defocus display value to the correct, absolute value of the Scherzer focus. When Scherzer is switched off, the focus will return to minimum contrast and the defocus display will read $0.4 * \text{Scherzer}$. By pressing the Scherzer focus the defocus display therefore goes from a relative setting (relative to the last time Reset Df was pressed) to an absolute setting.

	Scherzer on	Scherzer off
Objective-lens focus set	$0.6 * \text{Scherzer}$	$-0.6 * \text{Scherzer}$
Focus display value	Scherzer	$D = -0.6 * \text{Scherzer}$

If the focus is changed with the focus knob while Scherzer is active, the change in focus will be added to/subtracted from the value displayed for Scherzer focus. If Scherzer is then turned off, the display value will add the defocus difference between Scherzer and minimum contrast focus.

Contrast function

By applying a certain amount of underfocus the contrast in the TEM image can be enhanced. The increased contrast comes at the expense of image resolution. How much underfocus to apply depends on personal preference (balancing the amount of contrast enhancement needed and how blurry the image can become without losing information required) and the magnification (what may look alright at low magnification looks terribly blurred at high magnification). The microscope offers an automatic function for contrast enhancement. When activated the microscope will apply a certain amount of underfocus, dependent on the choice of the degree of contrast enhancement (in the Focus control panel) by the user (from very low to very high) and the magnification. The function assumes that the image has been set to Gaussian focus (0 nm) before it is activated. Because of the magnification dependence, the amount of defocus will automatically change when the magnification is changed with Contrast enhancement active.

4.37.2 Image shift

Caution: In the current version of the Tecnai software there is no software limitation on the amount of image shift allowed (the range of the image deflection coils is the limit). However, it should be realised that working far off-axis can affect the quality of the images due to the normal lens aberrations that occur away from the center of the magnetic lenses (such as coma). For lower-magnification work it is advised not to exceed a few micrometers for recording images, while for high-resolution imaging the image shift should ideally be limited to several hundreds of nanometers (200-300). For looking around the image shift can be used, but it is always advised to record images as close as possible to the center.

Special function: Click with the right-hand mouse button on one of the channels to get a popup-menu.

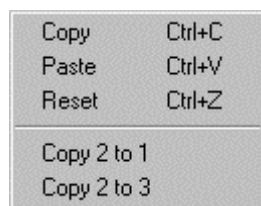

MF knobs

Pressing the MF knobs button couples (the button turns yellow) or decouples the Multifunction knobs to/from the Image shift. When the Image shift is controlled with the Multifunction knobs, the nature of the coupling (persistent or temporary) is indicated. Pressing the MF knobs is equivalent to clicking with the right-hand mouse button on the binding panel and selecting Image shift for the Multifunction knobs (coupling) or None/clear (decoupling).

Sensitivity

The sensitivity spin buttons set the step size for the image shift. Pressing the Multifunction +/- buttons is the same as decreasing/increasing the sensitivity when the Multifunction knobs are coupled to the image shift.

Channel

Shift settings can be stored in three channels. The active channel is outlined by a frame around it and by the enabled nature of its spin buttons (the arrows are black; those of the inactive channels are gray).

Spin control

Use the buttons of the spin control to change the Image shift setting (an alternative to using the Multifunction knobs).

Popup menu functions

Copy

Copies the contents of the channel in which the mouse was clicked to the clipboard.

Paste

Pastes the contents of the clipboard into the channel where the mouse was clicked. This menu item remains grayed (disabled) until a copy action has been done.

Reset

Resets the image shift channel to zero.

Copy ... to ...

Copies the content of the channel listed first to the channel listed second. The copy action is always from the channel where the right-hand mouse click was done to one of the other channels.

4.37.3 The image shift

The microscope is equipped with an image shift effected through the image deflection coils. The image shift has a compensating beam shift to keep the illumination centered on the area of interest. The beam shift compensation must be calibrated for the various modes (Microprobe, LM , Nanoprobe) before it will work properly.

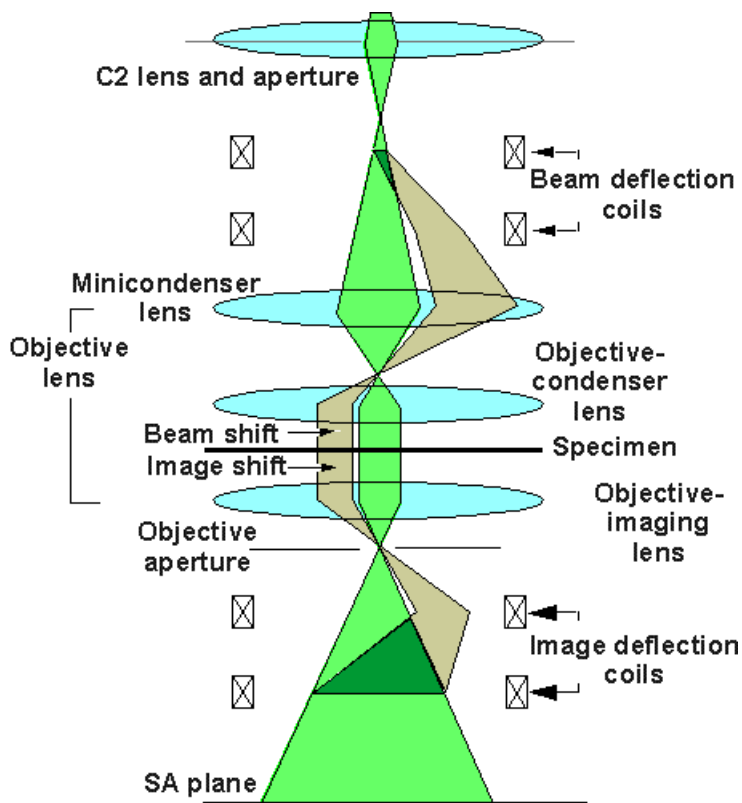

When the user shifts the image (from the central green ray path to the off-axis, tan ray path), the microscope automatically applies a compensating beam shift.

On the Tecnai 10 the Minicondenser lens does not exist, resulting in a somewhat changed ray path, but the principle remains the same.

Note: The settings of the image shift are not persistent (they are not stored by the microscope when a user logs out; all three channels are reset when the user logs in to the Tecnai User Interface).

4.38 Image Settings Focus

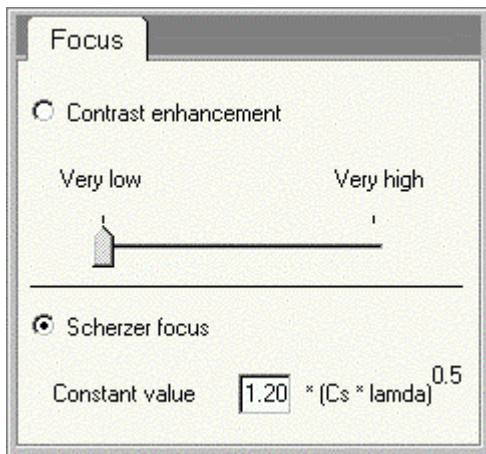

The Image Settings Focus Control Panel.

The Image Settings Focus Control Panel contains the parameter settings for the focus functions (Scherzer and Contrast enhancement).

Contrast enhancement / Scherzer focus selection

The two focus functions are accessed via the same button in the Image settings control panel (since their effect is similar and their application totally different, there is no point in having both functions directly accessible. Which function is selected is controlled by the two radio buttons (Contrast enhancement and Scherzer focus). You cannot change the selection when the focus function on the Image settings control panel is active.

Contrast enhancement setting

The slider defines the strength of the contrast enhancement, in five steps, from very low to very high. Higher contrast comes at the expense of resolution (image blurriness).

Scherzer focus

Although Scherzer focus is commonly defined as $1.2 * (Cs * \lambda)^{0.5}$, some people use other constants (like 1.0 or 1.1). You can change the value of the constant to the value you wish to use in the Scherzer focus edit control.

4.39 Measuring

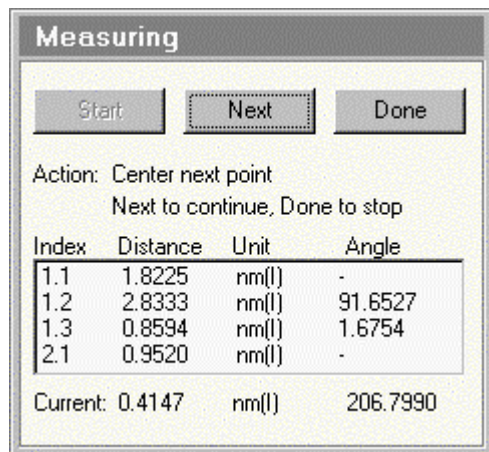

The Measuring Control Panel.

The Measuring Control Panel is used for on-line measuring on the microscope. On-line measuring can be performed in image mode (giving distances in the image and the angles between the distance vectors) and in diffraction (giving d spacings and the angles between the corresponding lattice planes).

Note: For accurate measurement it is very important that the image shift calibration and diffraction shift calibration have been done properly.

Start

When the Start button is pressed, a measurement cycle is started. Each cycle has its own serial number (the number before the period under Index in the measurement list) and within each measurement cycle individual measurements are also numbered (the number behind the period). Measurement cycles are unique for the current microscope session (the number 1 is used only once, etc.).

Next

When the Next button is pressed, the current measurement values are moved to the measurement list and a new (single) measurement is started.

Done

When the Done button is pressed, the current measurement value is moved to the measurement list and the current measurement cycle is closed.

Instructions

Before and during measurement, instructions are listed in the control panel.

Measurement list

The measurement list contains the values of all measurements performed. Each individual measurement occupies a line in the list. Each line contains four items:

- Index: contains the values of the measurement cycle (before the period) and the individual measurement (after the period). Measurements having the same cycle number belong together in a sequence.
- Distance: the distance value measured (distance in image mode, d spacing in diffraction).
- Unit: the unit (micrometer - μm - or nanometer - nm) of the measurement and the mode in which the measurement was done, (I) stands for imaging, (D) for diffraction.
- Angle: the angle between individual measurements of a cycle. These values have different meaning in imaging and diffraction, see the description below.

Current

The values listed under Current show the values of the measurement currently being done.

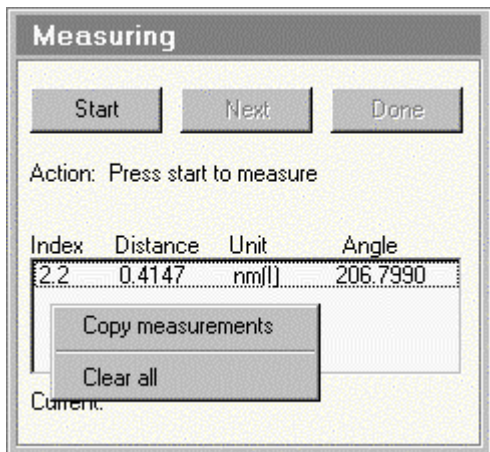

When the right-hand mouse button is clicked on the measurement list, a popup menu becomes visible that allows copying of all the measurements currently in the list to the clipboard (from where it can be pasted into Notepad, for example) or to clear all measurements (empty the list).

4.39.1 Measuring in imaging

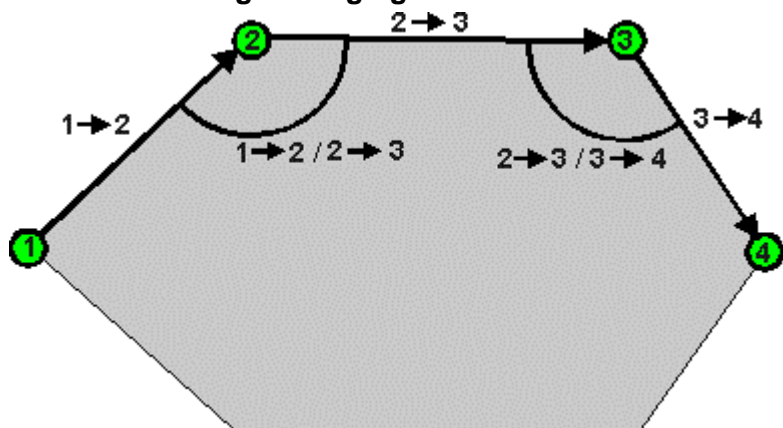

Schematic diagram of measuring in imaging, showing the vectors of consecutive measurements and the meaning of the angles.

Note: The image shift used for measuring is not the one with the compensating beam shift. During measuring the beam will move off with the image and must be recentered if the measuring goes beyond the edge of the beam.

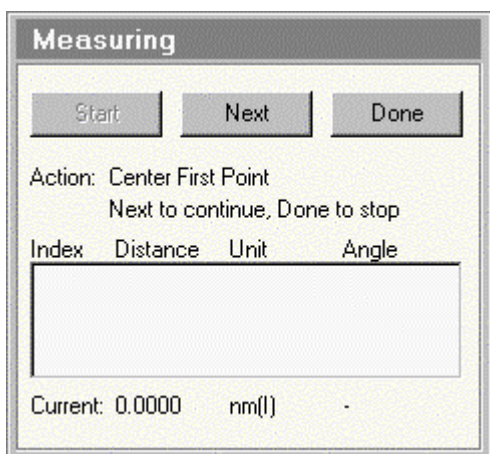

After the Start button has been pressed, the Multifunction knobs can be used to center a first image feature on the screen. Once the image feature has been centered, the Next button is pressed.

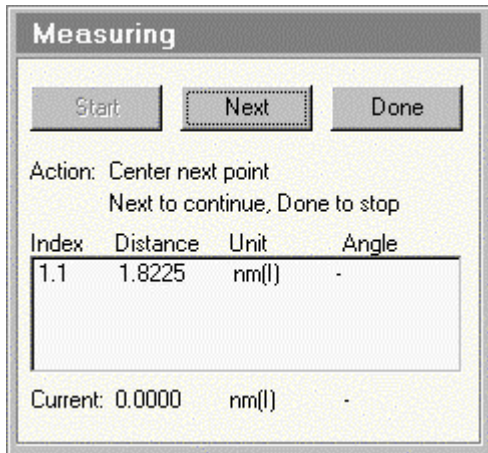

When the Next button has been pressed, the measurement is moved to the list and a next feature can be centered.

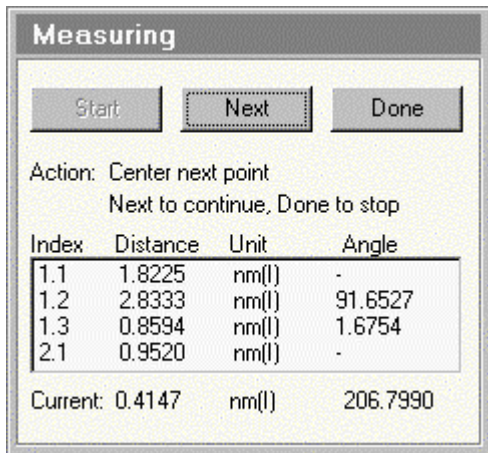

Measurements can be continued as long as is necessary by pressing Next once each new point has been centered.

4.39.2 Measuring in diffraction

Measuring in diffraction in essence works the same as in imaging, but with one major difference. In diffraction all measurements are done relative to the transmitted (central) beam. In imaging the vectors are 1-2, 2-3, 3-4, etc., while in diffraction they are 1-2, 1-3, 1-4, etc. The reason for this difference is very simple: when defined in this way, the angles are the angles between the lattice planes in the crystal structure.

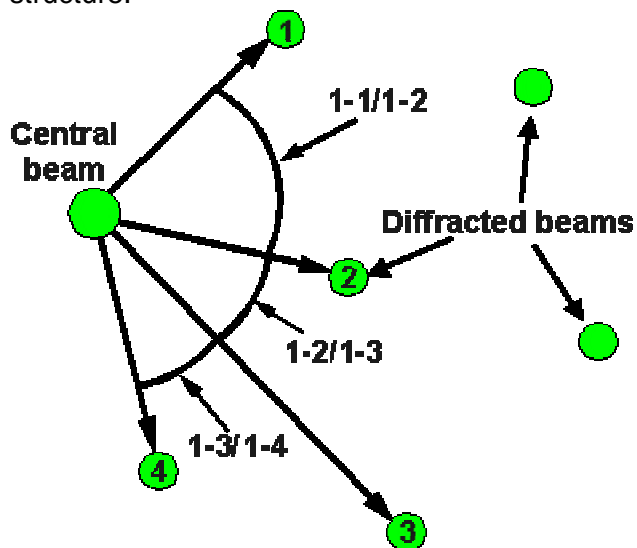

Schematic diagram of measuring in diffraction. All vectors are relative to the central beam.

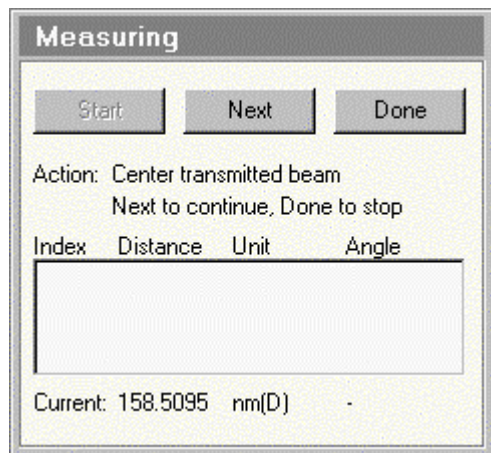

To measure in diffraction, press the Start button and center the central (transmitted) beam on the screen.

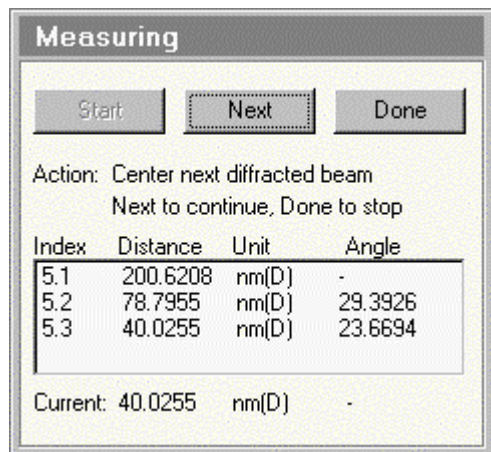

Once the central beam has been centered, press Next. Center the first diffracted on the screen and press Next to repeat the measurement for further diffracted beam.

The images below show diffraction measuring using the beam stop as reference point.

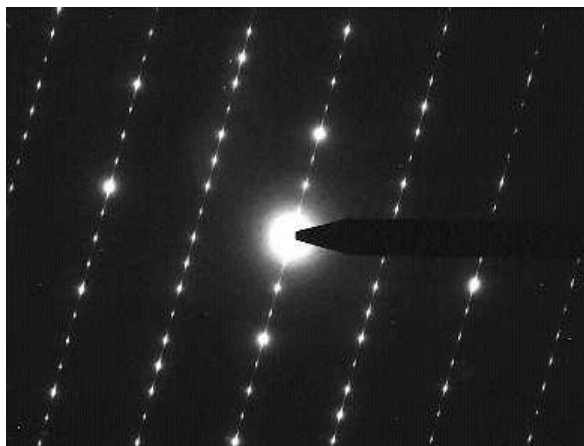

The central beam has been moved to the tip of the beam stop.

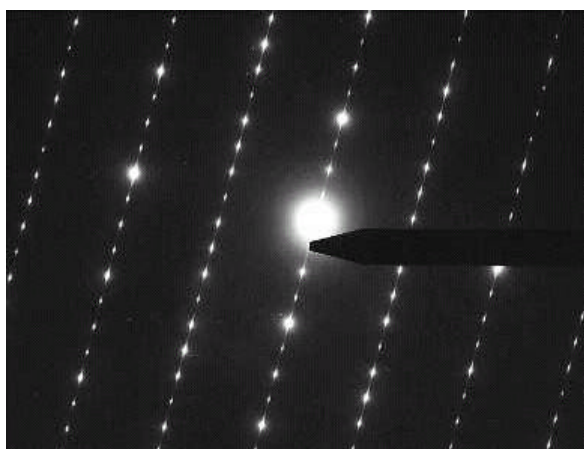

A diffraction beam has been moved to the beam stop. Now the d spacing for the diffracted is displayed.

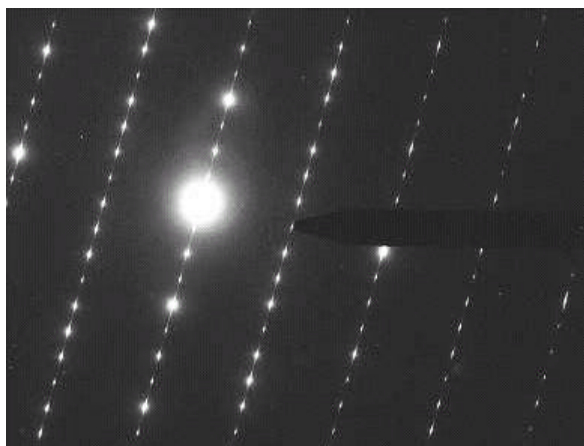

A second diffracted beam has been moved to the beam stop, and the d spacing of this second beam as well as the angle between diffracted beams 1 and 2 is displayed.

4.40 Multiple Exposure

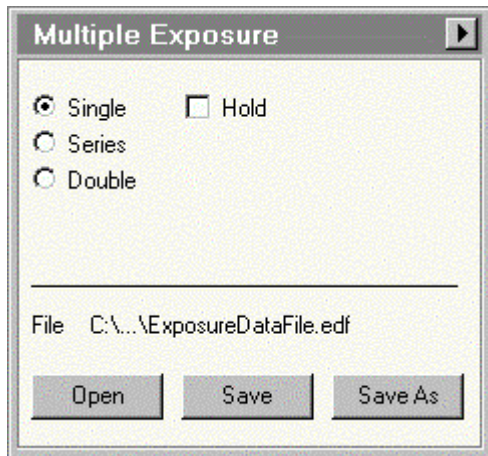

The Multiple Exposure Control Panel.

The Multiple Exposure Control Panel contains the controls used for recording multiple exposures. Multiple exposure can either be in series (a set of exposures on separate plates with user-defined focus values) or as double (a set of exposures on the same plate with user-defined exposure times).

Multiple exposure selection

The type of multiple exposure selection is chosen through one of the three radio buttons, Single (the normal default), Series or Double. The latter two radio buttons are only enabled when proper settings have been entered for them in the Series and Double control panels of the flap-out.

Note: If the Multiple Exposure control panel is not selected into the user-interface (through Workspace layout), the Multiple exposure setting by definition is single.

Hold

If the user selects a multiple exposure method that deviates from the default (single), the microscope will use the method set. If Hold is not checked, this new settings applies only to the next (series of) exposure(s). Afterwards the microscope will reset to the default method. To keep the method as selected by the user for more than one exposure, check the Hold option. If Hold is on, the method will stay as set until the user changes the selection or switches Hold off.

Saving/loading multiple exposure data to/from file

The multiple exposure settings can be saved to a file and reloaded later. This function can be useful when the same type of multiple exposures is recorded repeatedly. When a filename has been defined (either through a load or save) the name is displayed on the control panel.

Open

When the Open button is pressed, a standard Open File dialog will come up, where a file can be selected for reloading. The current series and double settings lists will be cleared and the values from the file entered in the lists.

Save

When the Save button is pressed, the settings are stored in a file. If a filename had been defined previously (through either Save, Save As or Open), that is the file under which the values will be saved. If no filename has been defined yet, a standard Save File dialog will come up, where a filename (and folder) can be set.

Save As

When the Save button is pressed, a standard Save File dialog will come up, where a filename (and folder) can be set. The current setting list will be saved in that file.

Multiple exposure flap-out

Pressing the arrow button displays the flap-out containing the Series and Double control panels.

4.41 Series

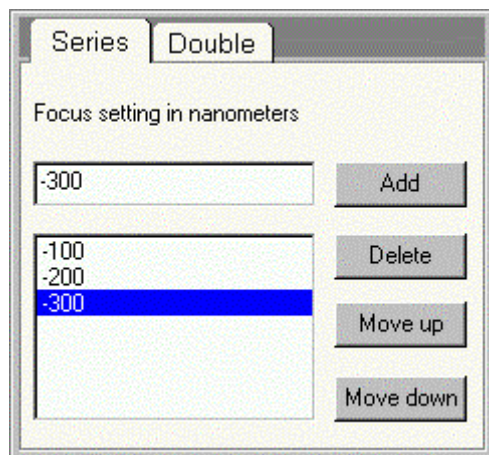

The Multiple Exposure Series Control Panel.

The series panel contains settings used for automated through-focus series. The through-focus series is totally flexible. It simply will execute as many exposures as there are entries in the list, changing the focus by the amount in the list for the particular setting. Multiple entries with the same value, or the value 0 are allowed. It is also allowed to enter a single non-zero value. In that case each exposure will be made with the focus offset by the specified amount (making it e.g. possible to focus to minimum contrast - close to zero or Gaussian focus - and have each image recorded at -1000 nm).

Note: The focus settings are not absolute but are values relative to the focus set when the exposure series is started.

Focus setting

The Focus settings list is filled by entering values for the focus (underfocus is taken as negative) in the Focus setting edit control in nanometers and pressing the Add button.

Focus settings list

The Focus settings list contains the list of values used for the through-focus series.

Add button

The Add button allows insertion of a new setting into the focus settings list. The value for the new focus must be inserted into the Focus setting edit control. The maximum number of values is 20.

Delete button

The Delete button allows removal of settings from the list. Select a setting and press Delete.

Move up

The through-focus exposures are recorded in the sequence as they occur in the list. To change the sequence, select a setting and press Move up to move it up in the list.

Move down

The through-focus exposures are recorded in the sequence as they occur in the list. To change the sequence, select a setting and press Move down to move it down in the list.

4.42 Double

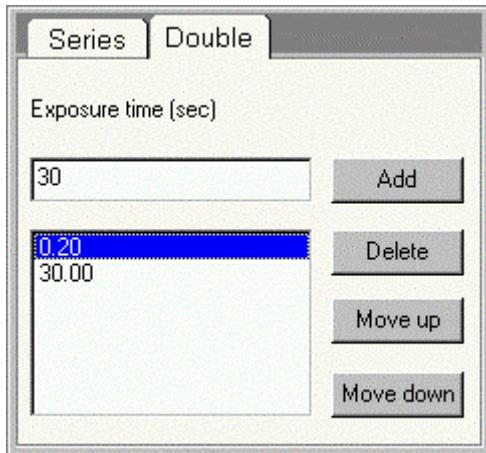

The Multiple Exposure Double Control Panel.

The double panel contains settings used for recording double exposure (multiple exposures on a single plate). The double exposure setup is totally flexible. It simply will execute as many exposures as there are entries in the list, changing the exposure times as indicated in the list for the particular setting.

The double exposure sequence is similar to that for a normal exposure except that the plate is not removed until the last double exposure has been done (or the exposure is cancelled). After one exposure has been recorded, further execution pauses until the operator presses the Exposure button (on the left-hand Tecnai Control Pad) again. Pressing this button while an exposure is taking place cancels further exposure, otherwise it starts the next exposure in the sequence. The dimmed screen will display a message alerting the operator to press Exposure to start the next exposure.

Between individual exposures of a double exposure sequence, it is possible to lower the screen and look at the image.

Exposure time

The exposure times list is filled by entering values for the exposure time (in seconds) in the exposure time edit control and pressing the Add button.

Exposure times list

The exposure times list contains the list of values used for the double exposure times. The maximum number of values is 20.

Add button

The Add button allows insertion of a new setting into the exposure times list. The value for the new exposure time must be inserted into the exposure time edit control.

Delete button

The Delete button allows removal of settings from the list. Select a setting and press Delete.

Move up

The double exposures are recorded in the sequence as they occur in the list. To change the sequence, select a setting and press Move up to move it up in the list.

Move down

The double exposures are recorded in the sequence as they occur in the list. To change the sequence, select a setting and press Move down to move it down in the list.

4.43 Normalizations

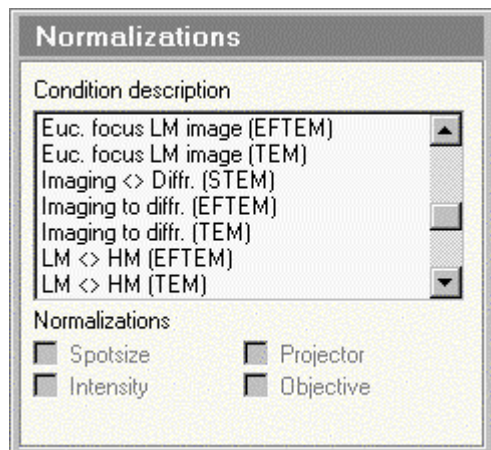

The Normalizations Control Panel.

The Normalizations Control Panel provides control over the normalizations executed by the microscope.

4.43.1 Introduction to normalizations

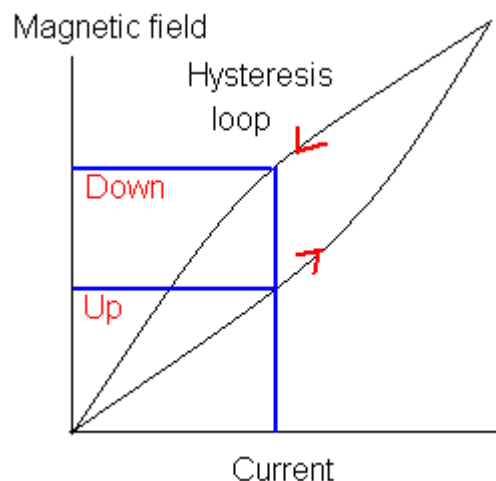

Magnetic lenses suffer from hysteresis, which causes a certain degree of non-reproducibility of the magnetic fields, dependent on the direction of change. The diagram below sketches how the magnetic field changes when the current through the lens coils goes up (lower curve) and goes down (upper curve). When the current goes up, the field increases but 'lags' somewhat behind. The opposite occurs when the lens current goes down. Therefore the effective field is higher when going down than when going up.

Hysteresis can have appreciable effects on the illumination system (C1 and C2 lenses) and the magnification system (Diffraction, Intermediate and Projector lenses) and as a consequence affect the spot position (illumination system) as well as the true magnification or camera length (magnification system). The image or diffraction shifts used for the image/diffraction alignment and the cross-over alignment (for Energy-Filtered TEM) can also be sensitive to the actual values of the magnetic fields of the lenses in the magnification system.

In order to make the lens fields more reproducible, the lens normalization can be executed. In the normalization procedure the lens(es) involved is (are) taken through a sequence completely up - then completely down - completely up again - and then down to the required value. The normalization brings the lenses to more reproducible settings - and, as a consequence, more reproducible magnifications/camera lengths, image/diffraction shifts and cross-over corrections.

Normalizations can be executed by hand (e.g. by assigning projector normalization to one of the Control Pad user buttons) and/or automatically. The automatic normalizations are determined by the settings selected by the user in the Normalizations control panel. Because automatic normalizations can be done for a number of different conditions, it is possible that more than one normalization is done. The system

has been made such that it doesn't start a new normalization while another normalization is still being executed, but only executes one final normalization. Thus, if automatic normalizations occur for each change in magnification step, then a normalization will be done for each individual step only if the magnification is changed very slowly. Otherwise the following happens:

- Change magnification -> execute normalization
- Normalization has started, magnification changed again
- x times magnification changed again, previous normalization still running
- Previous normalization finished, no more magnification changes
- Execute one final normalization

List of normalizations

The list of normalizations contains a series of possible conditions (changes in system settings) that can lead to automatic normalizations. Each of these conditions can have normalizations associated for spotsize, intensity, projector and/or objective. Associated normalizations have their check boxes enabled, as in the picture below (otherwise the check boxes remain disabled). All lenses selected for normalization are normalized together.

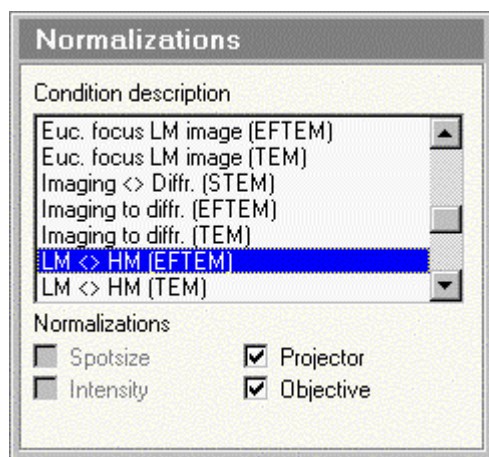

The list is arranged alphabetically, so STEM- and EFTEM-related items can come between the TEM conditions (dependent on the hardware configuration of the microscope). In the table below, the STEM and EFTEM conditions are listed separately from the TEM conditions for clarity.

Spotsize

When Spotsize is checked for the normalization condition in the list selected, the Spotsize (C1 lens) will be normalized when the condition (from the list) is encountered.

Intensity

When Intensity is checked for the normalization condition in the list selected, the Intensity (C2 lens) will be normalized when the condition (from the list) is encountered.

Projector

When Projector is checked for the normalization condition in the list selected, the Projection system (Diffraction, Intermediate, Projector 1 and Projector 2 lens) will be normalized when the condition (from the list) is encountered.

Objective

When Objective is checked for the normalization condition in the list selected, the Objective lens will be normalized when the condition (from the list) is encountered.

TEM Conditions	Description	Default normalizations
Camera length change (TEM)	When changing camera length	None
Diffr. to imaging (TEM)	When going from diffraction (D or LAD) to imaging (Mi, SA, Mh or LM)	Projector
Euc. focus HM diffraction (TEM)	When eucentric focus is pressed in HM diffraction (D)	Objective, Projector
Euc. focus HM image (TEM)	When eucentric focus is pressed in HM (Mi, SA, Mh) imaging	Objective, Projector
Euc. focus LM diffraction (TEM)	When eucentric focus is pressed in LM diffraction (LAD)	Objective, Projector
Euc. focus LM image (TEM)	When eucentric focus is pressed in LM imaging	Objective, Projector
Imaging to diffraction (TEM)	When going from imaging (LM or Mi, SA, Mh) to diffraction (LAD or D)	Projector
LM <> HM (TEM)	When switching between LM (objective lens off) and HM (objective lens on)	Objective, Projector
Magn. change (TEM)	When changing magnification (LM, Mi, SA, Mh)	None
Mi <> SA <> Mh	When changing between Mi and SA or between SA and Mh	None
Spotsize	When changing spotsize setting	Spotsize, Intensity
uP <> nP	When changing between microprobe and nanoprobe modes	Spotsize, Intensity, Objective
STEM-related Conditions	Description	Default normalizations
Camera length change (STEM)	When changing camera length	Projector
Euc. focus (STEM Image) Diffraction	When eucentric focus is pressed in STEM (TEM) diffraction	Objective, Projector
Euc. focus (STEM Image) Imaging	When eucentric focus is pressed in STEM (TEM) imaging	Objective, Projector
Imaging to diffraction (STEM)	When switching between imaging and diffraction (press Diffraction button)	Projector
TEM <> STEM	When switching between TEM and STEM	Projector
EFTEM-related Conditions	Description	Default normalizations
Camera length change (EFTEM) screen down	When changing camera length in EFTEM with the viewing screen down	None
Camera length change (EFTEM) screen up	When changing camera length in EFTEM with the viewing screen up	Projector
Diffraction to imaging (EFTEM)	When going from diffraction (D or LAD) to imaging (Mi, SA, Mh or LM) in EFTEM	Projector
Euc. focus HM diffraction (EFTEM)	When eucentric focus is pressed in EFTEM HM diffraction (D)	Objective, Projector
Euc. focus HM image (EFTEM)	When eucentric focus is pressed in EFTEM HM (Mi, SA, Mh) imaging	Objective, Projector
Euc. focus LM diffraction (EFTEM)	When eucentric focus is pressed in EFTEM LM diffraction (LAD)	Objective, Projector
Euc. focus LM image (EFTEM)	When eucentric focus is pressed in EFTEM LM imaging	Objective, Projector

Imaging to diffr. (EFTEM)	When going from imaging (LM or Mi, SA, Mh) to diffraction (LAD or D) in EFTEM	Projector
LM <> HM (EFTEM)	When switching between LM (objective lens off) and HM (objective lens on) in EFTEM	Objective, Projector
Magn. change (EFTEM) screen down	When changing magnification (LM, Mi, SA, Mh) in EFTEM with the viewing screen down	None
Magn. change (EFTEM) screen up	When changing magnification (LM, Mi, SA, Mh) in EFTEM with the viewing screen up	Projector
Mi <> SA <> Mh (EFTEM)	When changing between Mi and SA or between SA and Mh (in EFTEM)	Projector
TEM <> EFTEM	When switching between TEM and EFTEM	Objective, Projector

4.44 PEELS

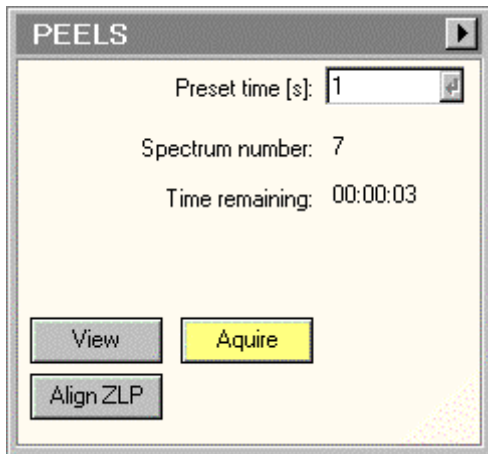

The PEELS Control Panel.

In the PEELS Control Panel the controls for (single-point) PEELS spectrum acquisition are located.

Preset time

The Preset time sets the acquisition time for the currently active acquisition mode (View, Acquire).

Spectrum number

During acquisition the spectrum number is displayed when more than one spectrum is acquired in a single acquisition.

Time remaining

During acquisition the time remaining before acquisition is finished is displayed.

View

Pressing the View button:

- When the button is gray, switches the PEELS acquisition settings to those of the View mode and starts acquisition.
- When the button is yellow, pauses PEELS acquisition.
- When the button is white, resumes PEELS acquisition (but starting with a new spectrum) if possible. If the start command could not be given to TIA, the button will remain white.

By definition View is continuous acquisition.

Acquire

Pressing the Acquire button:

- When the button is gray, switches the PEELS acquisition settings to those of the Acquire mode and starts acquisition.
- When the button is yellow, stops PEELS acquisition.
- When the button is white, resumes PEELS acquisition (but starting with a new spectrum) if possible. If the start command could not be given to TIA, the button will remain white.

By definition Acquire is single acquisition.

Align ZLP

The Align Zero-Loss Peak function in spectroscopy works different from that in imaging. In spectroscopy you use to set the scale of the EELS spectrum. Operation of the function is as follows:

- Acquire an EELS spectrum (continuous or single acquisition),
- Type in the value of the energy where the zero-loss peak is currently displayed under Energy shift in the Settings flap-out and press the Enter button.
- Press the Align ZLP button.

The energy scale should now have 0 at the position of the zero-loss peak.

Flap-out

Pressing the arrow button displays the flap-out with the PEELS Settings Control Panel.

4.45 PEELS CCD

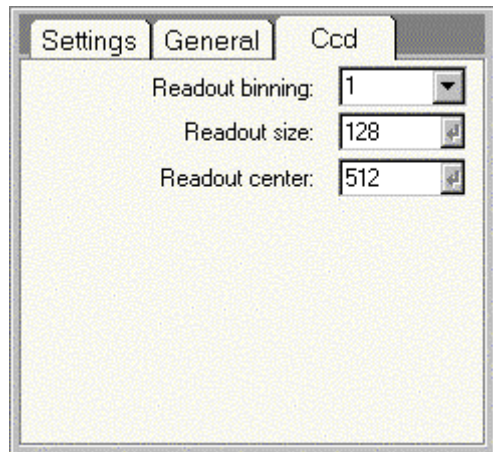

The PEELS CCD Control Panel.

In the PEELS CCD Control Panel the parameters for PEELS spectrum acquisition on a CCD camera (Imaging Filter) are defined.

Readout binning

The readout binning parameter defines the binning factor used for spectrum acquisition.

Readout size

The readout size parameter defines the number of pixels (perpendicular to the direction of the spectrum) read out during spectrum acquisition. Since the spectrum fills only a narrow band on the CCD, this number is typically around 100.

Readout center

The readout center defines the pixel (in the direction perpendicular to the direction of the spectrum) where the center of the spectrum is located. Unless the spectrum is displaced from the center of the CCD, this number is the half-height number of the CCD.

4.46 PEELS General

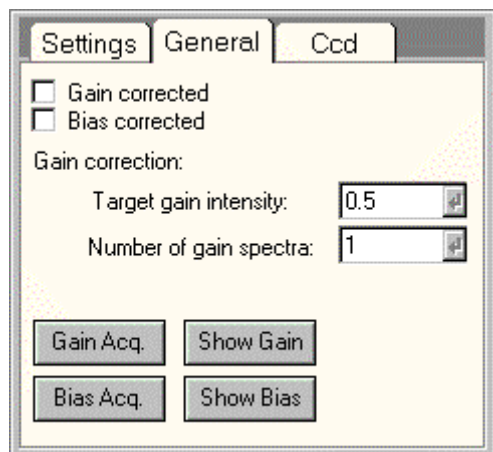

The PEELS General Control Panel.

In the PEELS General Control Panel general settings for PEELS spectrum acquisition are defined.

Gain corrected

Under Gain corrected the gain correction of the spectrum acquisition is switched on (checkbox checked) or off.

Bias corrected

Under Bias corrected the bias (dark current) correction of the spectrum acquisition is switched on (checkbox checked) or off.

Target gain intensity

Under target gain intensity the intensity aimed at during acquisition of the gain spectrum is defined.

Number of gain spectra

Under number of gain spectra the number of spectra acquired for gain-spectrum acquisition is defined.

Gain Acq.

Pressing Gain Acq. starts acquisition of the gain spectrum. Make sure no specimen is visible in the beam and that the beam is sufficiently reduced to avoid overexposure.

Show Gain

When the Show Gain button is pressed, TIA will display the gain image.

Bias Acq.

Pressing Bias Acq. starts acquisition of the bias spectrum. Make sure no beam is falling on the spectrometer (screen down).

Show Bias

When the Show Bias button is pressed, TIA will display the bias image.

4.47 PEELS Settings

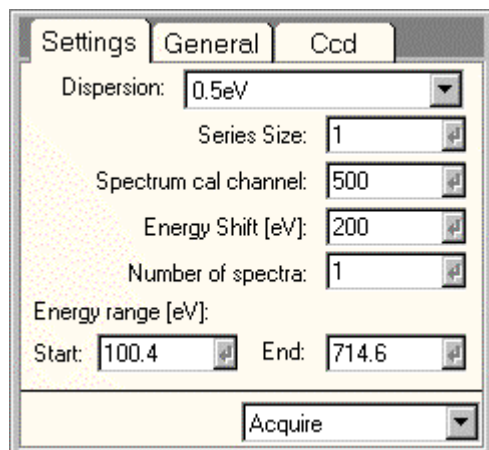

The PEELS Settings Control Panel .

In the PEELS Settings Control Panel the settings used for PEELS spectrum acquisition are defined.

Dispersion

The drop-down list contains the accessible dispersion settings for the PEELS detector. This list corresponds to the list of the More PEELS Dispersions tab in TIA.

Series size

Under series size the size of the acquisition series for the currently active acquisition mode is set.

Spectrum cal. channel

The spectrum cal. channel parameters defines the channel at which the Calibration shift tool is applied (the same as under Properties of the spectrum in TIA itself).

Energy shift

The energy shift defines the energy offset of the spectrum (the same as under Properties of the spectrum in TIA itself).

Number of spectra

Under number of spectra is defined how many spectra are acquired (added together) during a single acquisition.

Energy range

The Start and End values define the start and end energy (in electronvolt) of the spectrum.

Acquisition mode

In the acquisition mode drop-down list, the acquisition mode for which the parameters must be defined, can be selected. The difference between selecting the acquisition mode through the drop-down list and by pressing the equivalent button in the main control panel is that the drop-list selection selects the mode but does not automatically start acquisition.

4.48 Plate Camera

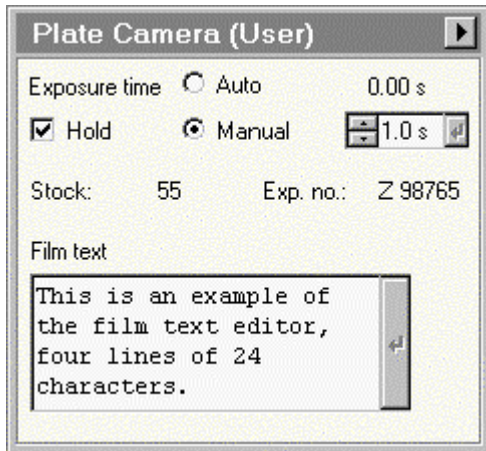

The Plate Camera Control Panel.

The Plate Camera Control Panel contains the controls used for the plate camera.

Description

The plate camera is located immediately underneath the viewing screen (the magnification ratio between main screen and plate camera is 0.885). On the bottom of the projection chamber a guide is mounted along which the tray containing the negative in its film holder will be slid forward, out of the cassette, and backward after the exposure. The complete exposure sequence contains the following steps:

- Check external shutter control status and switch external shutter control off (see below)
- Close microscope shutter
- If necessary, move viewing screen up
- Load plate
- After the settling time expose the plate label
- Make the real exposure (open shutter, wait for the exposure time to finish, close shutter)
- Unload the plate
- Open the microscope shutter
- If necessary move viewing screen down and restore external shutter

The microscope will automatically restore the main screen to the position it had before the exposure and also restore the external shutter control to its previous setting.

4.48.1 Combining plate camera and CCD

The shutter control on the Tecnai microscope differs from that of the CM series (because of occasional problems there in case plate-camera use was combined with a slow-scan CCD camera; unless one was careful the CCD camera would keep the shutter closed during plate-camera exposure, resulting in blank negatives). On the Tecnai microscopes the shutter control is not serial. The shutter is controlled either by the plate camera or by the CCD, with the switch under software control. Before a plate-camera exposure is taken, the microscope checks the status of the shutter control (internal = plate camera; external = CCD) and automatically switches the external control off. The status of the shutter control of the CCD is thus not important for plate-camera use.

Warning: The previous note does not apply when the CCD shutter is using the beam blanker (alternate shutter). If that is the case, the user must ensure that the CCD does not close the shutter (i.e. blanks the beam) when the viewing screen is raised.

Note: Because of the construction of the camera, the negative will lie exposed to any light coming in through the windows of the projection chamber. Before taking any exposure, make sure:

- The windows (especially the side window) are covered with the covers provided.
- Room light are off (or strongly dimmed).
- No bright displays are on the monitor, from which light could reflect off the operator into the projection chamber.

Exposure time

The exposure time is measured continuously when the main viewing screen is down. The time is based on a conversion of the screen current coming from the main screen or the focusing screen, via the emulsion setting, to an exposure time. When the focusing (small) screen is in, the measurement is automatically adjusted for the smaller area of the focusing screen. If the image intensity is reasonably uniform across the whole viewing screen, the exposure time measured on the large screen, with the small, focusing screen out, can be used to determine the exposure time for the plate camera. If the image intensity is not uniform (strong differences, for example because part of the image is covered by grid bars), the exposure time from the small screen should be taken.

Note 1: When the small-screen exposure time must be used, do not move the small screen back by hand (the exposure measurement will immediately jump back to the main screen). Lift the main viewing screen (the small screen will be moved out automatically) or start the exposure itself by pressing the Exposure button on the left-hand Control pad. Alternatively, note the exposure time as measured with the small screen and set that as the manual exposure time.

Note 2: As a rough guide for diffraction patterns, 1/3 of the exposure time measured (and then set as manual time) is often a good value. Exposures of diffraction patterns should not be taken for very short exposure times. In general diffraction patterns (especially Selected-Area diffraction patterns) have very intense spots and because the microscope shutter is not instantaneously off, short exposure times will lead to spots displaying a (curved) tail. In general diffraction pattern exposure times should be 5 seconds or more.

From the exposure time it is possible to get an estimate of the beam current by making sure the beam is not (partly) off the viewing screen, then using the following formula:

Beam current (in nanoAmps) = 2.15 x emulsion setting / exposure time

Auto

If Auto is checked, the plate camera will use the exposure time as measured. If Hold is on, the microscope will not adjust the exposure time method to the mode defaults (automatic in image, manual in diffraction) but keep it as set.

Hold

The plate-camera exposure time method used by the microscope depends on the mode (automatic in image, manual in diffraction). If the user selects a method that deviates from the default, the microscope will use the method set. If Hold is not checked, this new settings applies only to the next exposure. Afterwards the microscope will reset to the default method. To keep the method as selected by the user for more than one exposure, check the Hold option. If Hold is on, the method will stay as set until the user changes the selection or switches Hold off.

Manual

If Manual is checked, the plate camera will use the exposure time set with the spin-edit control. If Hold is on, the microscope will not adjust the exposure time method to the mode defaults (automatic in image, manual in diffraction) but keep it as set.

Stock

The stock value displays how many exposures are still available in the plate-camera magazine.

Exposure number

The exposure number is a six-character code that is printed on the negative. The first character can be a letter (A..Z) or a number (0..9), the remaining five are a number that goes from 00000 to 99999. When the number exceeds 99999, the number automatically switches to the next character up for the first one (9 goes to A, Z goes back to 0).

The exposure number is updated immediately after the exposure has been taken. The number displayed is therefore the number that will be printed on the next negative.

Film text

The plate labeling system of the plate camera prints a number of settings on each negative. The magnification and plate number are always printed. Other values such as mm marker, date and user code are optional, set under Plate camera options. These values take up the two top lines of the plate labeling system. Underneath is room for four lines of 24 characters each, available for user comments. These four lines are defined in the edit control underneath the film text label. The size of the edit control is set automatically so that no more than 24 characters fit on a line (hence also the non-proportional Courier font used). New words that do not fit at the end of a line will automatically be wrapped to the next line.

Note: The film text is set only when the Enter button to the right of the edit control is pressed. Once the film text has been updated, the Enter button becomes disabled until the text in the edit control is changed. The status of the Enter button thus indicates the status of the film text. Only when the button is disabled, is the film text up-to-date.

Plate camera flap-out

Pressing the arrow button displays the flap-out containing the Options, Stock and Settings control panels.

4.49 Plate Camera Options

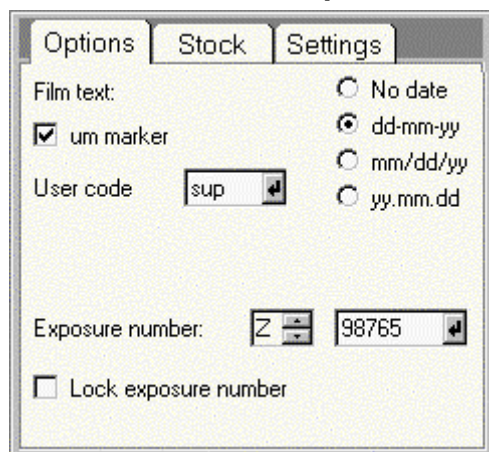

The Plate Camera Options Control Panel.

The Plate Camera Options Control Panel (in the Plate Camera flap-out) covers various aspects of the plate label displayed on the negatives. These options are specific for individual users. They are stored and are reset automatically when the user logs in.

um Marker

If the um marker option is checked, the plate labeling system will write a micrometer marker on the negative. The marker is in real-space units (micrometers, nanometers) in image mode and in reciprocal-space units (inverse micrometers or nanometers, denoted by a superscript -1).

User code

The user code is a sequence of up to three characters that is printed on the negative behind the exposure number. To leave a space between the user code and the exposure number, start with a space and then add two more characters. The user code is set when the enter button of the control is pressed.

Date

The microscope can add a date to the plate label in various formats as displayed by the various options.

Exposure number

The exposure number is a six-character code that is printed on the negative. The first character can be a letter (A..Z) or a number (0..9), the remaining five are a number that goes from 00000 to 99999. When the number exceeds 99999, it automatically switches to the next character up for the first one (9 goes to A, Z goes back to 0).

Lock exposure number

There are two methods for using the exposure number system (the method is decided by the supervisor):

- Users are free to change the exposure number. In this case, each user can adjust the exposure number. When the user logs out, the last exposure number used is remembered and restored automatically when the user logs in again (any changes made by other users therefore have no effects on the user's own exposure numbers).
- The exposure number system is locked. The exposure number can be changed only by the supervisor. The exposure numbers run in sequence, independent of the users.

4.50 Plate Camera Settings

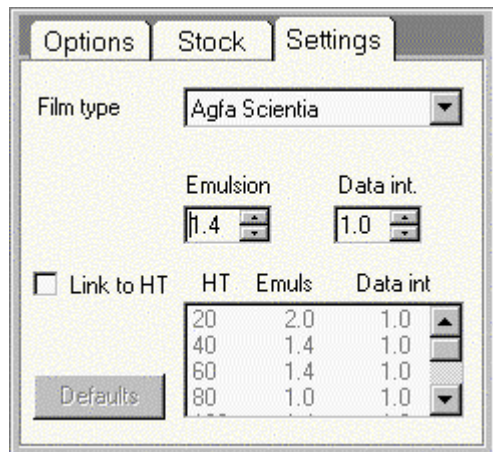

The Plate Camera Settings Control Panel.

The Plate Camera Settings Control Panel (in the Plate Camera flap-out) provides control over film type settings.

Film type

The film type drop-down list box provides settings for a number of different film types. This list makes it easy to switch between different film types (in case more than one film type is used). Currently it is not possible to add or change film type settings.

Emulsion

The emulsion setting determines the effective exposure time through the conversion factor (multiplication) between screen current and exposure time. In general the emulsion setting will be a function of the type of film and the developing conditions used. However, be aware that the effect of electrons on film depends on the high tension, with a peak in the interaction around 80 kV.

Note 1: Do not assume that emulsion settings are the same as ones used on other instruments (unless the instrument used before is of the same type as the Tecnai microscope). Differences in instrument make (manufacturer) and high tension do affect the emulsion setting. Always test a range of emulsion settings and developing times to find the optimum setting.

Note 2: Although it usually is possible to vary both emulsion setting and developing conditions, there are certain consequences. One aspect of electron images is the so-called shot noise. The shot noise is equivalent to the square root of the signal. Thus the change from emulsion 2.8 to 1.4 increases the noisiness of the image by the square root of 2. Unless it is necessary to use lower emulsion settings, it is advised to use somewhat higher settings and develop for a shorter time.

Data intensity

The plate label is exposed on the negative with an exposure time that is determined by the data intensity. The higher the number the longer the exposure time and the stronger the exposure of the label. The exposure of the plate labeling is separate from that of the electron image. A setting of 1.0 corresponds to a plate-labeling exposure time of 0.5 seconds.

Note: Fuji image plates are not sensitive to the light used for the plate labeling and the data intensity is meaningless in that case.

Link to HT

If the Link to HT option is checked, the emulsion setting and data intensity will be set automatically to the values in the table when the HT is changed. This option therefore automatically compensates for the change in interaction between electrons and film at different high tension settings.

Table

The table lists the high-tension specific settings used when the Link to HT option is on. The setting highlighted is determined by the currently active high-tension. The values in the table can be changed by changing the emulsion and data intensity settings in the spin-edit controls above the table. To change values for other high-tension settings, change to the required high tension and then change the values.

Note: In general there is no reason to assume the data intensity should be different for the various high-tension values, unless different developing conditions are used for different high-tension settings.

Defaults

Resets the table of HT-linked emulsion settings to the default settings.

4.51 Plate Camera Stock

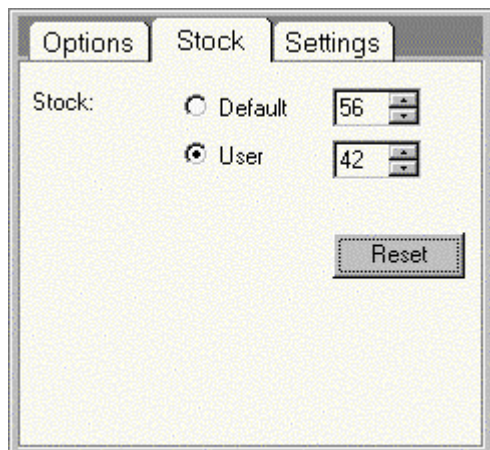

The Plate Camera Stock Control Panel.

The Plate Camera Stock Control Panel (in the Plate Camera flap-out) provides access to controls for the stock of exposures. The stock is a system-wide (not user-specific) setting.

Default

If a full cassette with plate camera negatives has been loaded, the available stock can be reset to the default value (typically 56, but other settings may be customary). Select the Default option and press Reset.

User

If the cassette placed in the plate camera is not full, the stock can be reset by changing the number of negatives in the spin-edit control, selecting the User option and pressing Reset.

Reset

Reset sets the current stock value to the number set under Default (if the Default option is checked) or the number under User (if the User option is checked).

4.52 Stage²

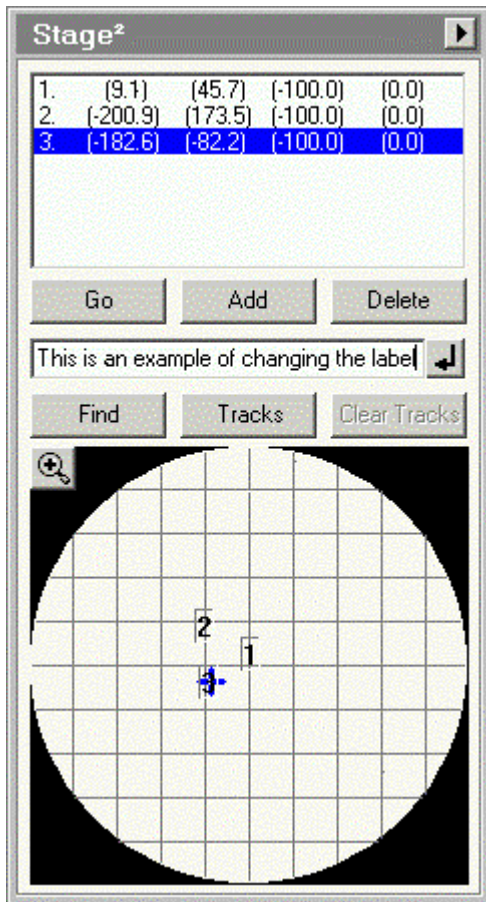

The Stage² Control Panel.

The Stage² Control Panel provides functionality for controlling the CompuStage, storing positions and tracks.

A more detailed description of the CompuStage and specimen-holder handling is given elsewhere. Two important topics are pointed out here especially :

- Movement: selection of trackball or joystick mode, the two different ways of using the trackball to move the stage.
- Specimen-holder selection : for single-tilt holders the message where the holder type selection must be done can be avoided and the last-used single-tilt holder will be selected automatically.

Note: The positions list nor the file format for storing positions is NOT compatible between the 'old' stage control panel and the new Stage² panel. Use one or the other, but not both intermixed. Neither control panel is aware of stage positions stored in the other panel.

4.52.1 Positions

The Stage² control panel allows the user to store stage positions. All positions are stored with five axes (if no b tilt is available, b will be 0). In addition a series of optics settings are stored :

- Magnification mode and magnification index
- Spot size
- Intensity setting
- Lens series (Zoom or EFTEM) (if available)
- TEM or STEM (if available)
- Lorentz mode off or on (if available)
- Defocus

These settings can be recalled together with the stage position (user-defined option).

Furthermore, the software keeps a label with each stage position (if no label is defined by the user the label will be a serial number plus the stage position).

Finally the software keeps track of plate and CCD exposures made at stored positions.

4.52.2 Tracks

Tracks are a list of stage positions automatically recorded and drawn as connected lines on the display. You can use tracks e.g. to mark which part of the specimen has been seen or to draw the outline of different areas on the specimen. For the latter, go to the perimeter of a first area, switch tracking on and move around the perimeter of the area until you are back where you started. Switch tracking off and move to the next area. Switch tracking on again and move around the perimeter of the new area. When done, switch tracking off again. Repeat as often as needed. By switching tracking off in between area, the tracks of the separate areas will be shown without any connection between them.

4.52.3 Confirmation

Several action require confirmation. This means that the button pressed will disappear and its place will be taken by an a combination of an OK and a Cancel button. The Cancel button is given the focus (which means that if you e.g. press the keyboard Enter, you cancel) and the cursor position is moved in between the two buttons (so that you do not accidentally press OK by clicking twice on the original button). The action is performed when the OK button is pressed (this will bring back the original button). Pressing the Cancel button will bring back the original button without performing the action.

4.52.4 Files

Stored positions and tracks can be saved to and loaded from file. The file format is digital and described separately.

Positions list

The positions list contains the list of stored positions. These are shown as a serial number plus a label. The serial number is set automatically and is not necessarily consecutive. If you delete stored positions, the numbers will not be redone but stay as they are. So if you have stored 6 positions, then delete 5 and 6, then add a new position, that new position will be number 7.

The serial number only gets reset when all positions are deleted.

Go

When the Go button is pressed, the stage will move to the stored position selected in the list. If more than one position is highlighted (this is possible with Shift+Click or Ctrl+Click to allow the deletion of more than one position at a time), the position selected is the one that was clicked on first.

The method of movement, Move To or Go To is defined on the Settings Control Panel.

Add

When the Add button is pressed the current stage position and the optics are stored into a new position. When no text is present in the edit control for defining the label, the label will have the stage position (as in the picture above). If there is text in the edit control, that is used for the label. Note that this may mean

that the new position gets the same label as a previous position. If you want to be sure that the label has the stage positions, erase anything in the edit control before pressing the Add button.

Delete

When the Delete button is pressed, two different things can happen:

If only one position is selected in the list, that position is deleted immediately. There is no confirmation needed.

If more than one position is selected in the list (with Shift+Click or Ctrl+Click), the deletion of all positions selected must be confirmed..

Label

The edit control allows the definition of a label to be used for a stored position :

If text is present when adding the position, that text automatically becomes the label.

If you wish to change the label of a position, you must enter the text in the edit control and then press the Enter button.

The text in the edit control is also used with the Find function.

Enter button

The Enter button allows changing the label of the position selected in the positions list. Enter the new label in the edit control and press the Enter button. The changing of the label must be confirmed.

Find

When there are more positions stored than visible in the list (or their labels are so large that they are not visible completely), the Find function allows searching for positions on the basis of text in the labels. Enter the search text in the edit control for the label and press the Find button. The search function will go down the list to the next position that has a match, starting at the currently selected position. If nothing is found further down, the function will continue from the top of the list down. If nothing is found at all (which means that the required text does not exist - with the possible exception of the currently selected position which is not included in the search), the software will sound a beep. If the text occurs in more than one position, you can simply press the Find button again to go further through the list.

Note: The separation between the serial number and the rest of the label and stage position values in labels is a tab, not a space. Generally you cannot enter a tab in the edit control with the keyboard (Windows will move the focus to the next control). If you need to search with tabs included, type the text, including tabs in Notepad, then copy the text into the edit control (Ctrl+V).

Tracks

Pressing the Tracks button switches tracking on (the button becomes yellow) and off.

Clear tracks

Pressing the Clear Tracks buttons removes all tracks together (you cannot remove separate tracks). This requires confirmation.

Zoom

When the Zoom button is pressed, the display zooms in or out, depending on its current status (which can be seen from the plus or minus sign in the magnifying glass).

Display

The display shows an overview of stored positions and tracks. Positions are shown by their serial number, outlined by a box. Tracks are shown as lines. The current position is shown by a yellow cross. There are two major functions associated with the display :

- When you let the cursor hover over a stored position, a hint will come up that lists the label, stage position (X,Y) plus, if relevant the notice 'Plate recorded' with the plate number or 'CCD image recorded'. If the hint disappears before you have been able to read all, move the cursor a bit off and back and the hint will re-appear.
- When you double-click on a stored position in the display, the stage will go there, including restoring the optics if selected (the function is thus the same as selecting the position in the list and pressing the Go button). When you double-click on the display outside any stored position, the stage will move to that position.

The display has two zoom positions. In the Out position (the magnifying glass in the Zoom button has a plus sign), you see a representation of the whole specimen area - a blue circle with a diameter of 2 mm. The black edges are outside realistic positions (the stage can move there but the specimen holder will block the beam). The stage X axis is horizontal in the display, while the Y is vertical.

In the **In** position (the magnifying glass in the Zoom button has a minus sign), the size of the area is determined by the minimum and maximum of the stored positions and tracks.

Note that the current stage position may fall outside the area defined. In the top right corner is a small display of the whole specimen (blue circle with black edges) with a white square marking the zoomed area.

If a stored position falls either underneath the Zoom button or the overview top right, it is not displayed.

Gray grid lines at 200 um intervals (stage coordinates) may be displayed (user option).

Flapout

The flapout button of the Stage² Control Panel opens the flapout with the Control, File, Set and Settings tabs.

4.53 Stage² Control

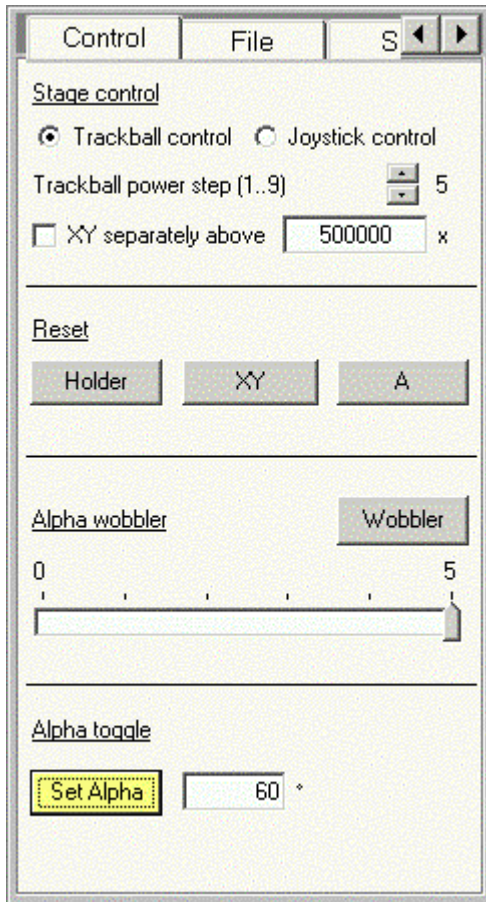

The Stage² Control Control Panel.

The Stage² Control Control Panel provides control over stage settings.

Trackball / joystick control

The CompuStage trackball has two modes of operation, trackball mode and joystick mode. You can change between these modes by pressing the trackball buttons (left and right) simultaneously or by changing the selection through the radio buttons in the Stage² Control Control Panel. The radio buttons also display the currently active setting.

Trackball power

The speed of movement of the CompuStage depends on a number of factors. One of these is the setting of the trackball power, which is defined in 9 steps by the trackball buttons (left is down, right is up). You can also set the trackball power value with the spin buttons in the Stage² Control Control Panel. The spin buttons also display the currently active setting.

XY separately

Generally the movement of the CompuStage when driven with the trackball is in the direction defined by the direction of trackball movement. It is thus a combined X,Y movement. This works well at lower magnifications where the movement on both axes is generally large enough, but at high magnifications one of the axes may no longer be able to make sufficiently small steps (so instead of moving 2+0.5, 2+0.5 for X+Y the stage may do 2+0, 2+1, etc.). The resulting movement is not as predictable in the movement direction. Under these circumstances it may be better to switch to XY separately. In that mode, only one axis is driven at a time. The trackball movement is divided into segments (north, east, south, west) and the trackball movement only makes the stage move in those fixed directions.

Since the change from XY separately to normal movement and back is largely a matter of magnification, you have the microscope change to XY separately automatically (when a check mark is present in the check box) at the magnification defined.

Reset holder

Resets all axes to zero. It is advised to use this function (or at the very least Reset AB before removing a specimen holder from the microscope).

Reset XY

Resets the XY position to 0,0.

Reset A / Reset AB

Reset the tilts to zero.

Wobbler

The Alpha wobbler tool helps in setting the eucentric height. When the wobbler is switched on (the button will turn yellow), the CompuStage will tilt continuously on a from minus to plus by the value set with the alpha wobbler track bar. By changing the Z height and minimizing the image movement, the CompuStage is set to the eucentric height.

Wobbler amplitude

The alpha wobbler track bar sets the alpha wobble angle. The maximum value is 15 degrees (5 degrees for the U-TWIN lens), but the user can set any angle less than that (except 0 which will lead to a disabled Wobbler button).

Set alpha

The Set alpha function provides a rapid toggle between an a angle and back to 0°. This function can be used for different things:

- Inserting a cryo holder with liquid nitrogen in the dewar into the airlock without spilling the nitrogen. Tilt the stage with the Set alpha function to 60°. Insert the holder into the airlock. Once the airlock pumping is finished, hit the Set alpha button again (it will automatically have focus normally so you can also do this by hitting the keyboard Enter button or the spacebar). As the CompuStage tilts back, insert the holder further into the microscope.
- Toggling between a preset angle for EDX spectrum acquisition (typically 10 to 20°) and back to 0°. To work with the Set alpha function, enter the desired angle. press the Set alpha button. During movement it will become disabled, but afterwards it will be yellow and have the focus. Hit it again and the stage will tilt back to 0° and the button will become gray again.

4.54 Stage² File

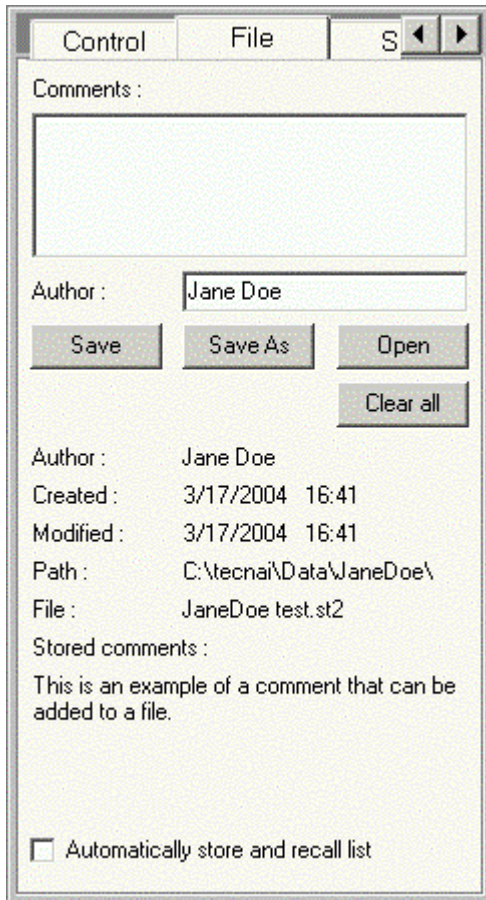

The Stage File Control Panel.

The Stage File Control Panel allows saving and reloading of stage positions to and from file. The positions are those as listed in the positions list of the Stage² Control Panel.

Note: The positions list nor the file format for storing positions is compatible between the 'old' stage control panel and the new Stage² panel. Use one or the other, but not both intermixed.

Comments

Comments can be added to files with specimen-stage positions. Enter the comment before saving the file. After opening the file, the comment from the file is listed under the file data.

Author

The name of an author (the person storing the positions and saving the file) can be added to the files with specimen-stage positions. When first used, the software will automatically enter your Windows logon name here. Once you change it, the software will remember and re-insert it automatically.

Save

When the Save button is pressed, the specimen-stage positions and/or tracks are stored in a file. If a filename had been defined previously (through either Save, Save As or Open), that is the file under which the positions will be saved. If no filename has been defined yet, a standard Save File dialog will come up, where a filename (and folder) can be set.

Save As

When the Save button is pressed, a standard Save File dialog will come up, where a filename (and folder) can be set. The current positions list will be saved in that file.

Open

When the Open button is pressed, a standard Open File dialog will come up, where a file can be selected for reloading. The current positions list will be cleared and the positions from the file entered in the list.

Clear All

The Clear All button clears all stored positions and tracks (it is thus equivalent to selecting all positions in the list and pressing Delete + confirm plus pressing Clear Tracks + confirm). This function may be useful in connection with opening files or clearing data that have been reloaded automatically. Clear All requires confirmation.

File data

After a file has been opened the essential data of the file are displayed. Note that the path may be in short format (with part of the path - between \\ - replaced by ...) in case the path is too long.

Automatically store

The stored positions and tracks may be saved automatically to a temporary file and reloaded when the Tecnai user interface is closed and re-opened. Note that temporary files are not replaced if there currently are no data (positions or tracks). If there are no data, the file stays as is, so the next opening of the Tecnai user interface will reload the data from the session before the last one.

4.55 Stage² Set

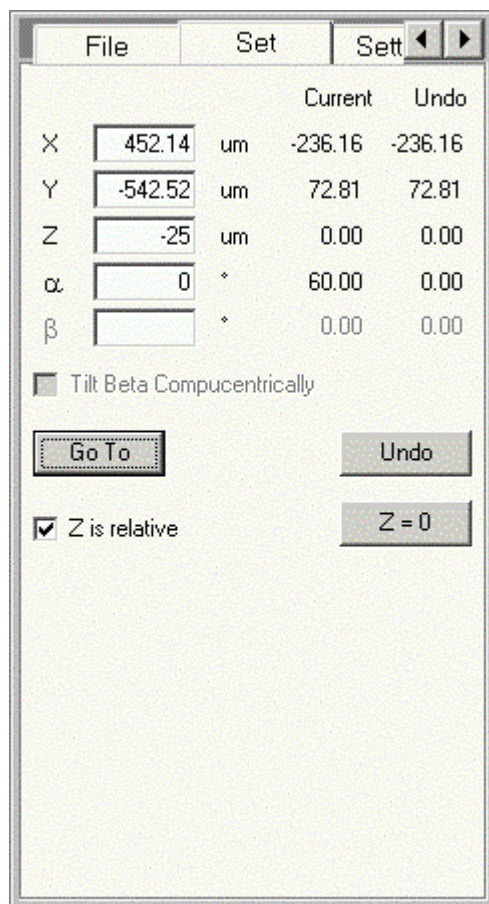

The Stage² Set Control Panel.

The Stage² Set Control Panel allows control over specimen-stage positions by entering stage-axis values.

Set position

The specimen-stage X, Y, Z, a, b position defines the value (in mm for X, Y, Z, degrees for a, b) for the new specimen-stage position set after the Go To button is pressed. If no value is entered for a particular axis, that axis remains unchanged.

Current position

The current position lists the current stage position.

Undo position

The undo position lists the position where the stage will go back to when the Undo button is pressed. Note that this movement is the reverse of the Go To, so only those axes used in the Go To will be used in the Undo.

Tilt beta compucentrically

If Compucentricity is available on the microscope, tilting on the b axis can be done compucentrically. See the compucentricity documentation for more details.

Go To

When the specimen-stage position Go To button is pressed, the specimen-stage is instructed to go to the position as defined by the four (X, Y, Z, a) or five (X, Y, Z, a, b) position edit controls. The button remains disabled until at least one value for a new stage position has been entered. If no value has been entered for a particular axis, the setting of that axis will remain unchanged in the Go To.

Undo

When the Undo button is pressed, the specimen-stage returns to the last position set by a Go To.

Z is relative

The Z position as reported by the stage is normally defined by the eucentric height (since that is where you should be working). Manipulating the Z then always means you have to start calculations with the Z position for the eucentric height, which may be cumbersome. The Z is relative function allows an automatic recalculation of the eucentric Z so this becomes 0 as displayed. All other positions are then displayed in values relative to this.

Note: Only the values as displayed in the Stage² Set Control Panel have their Z values adjusted, NOT any other displayed values (as e.g. in the general microscope information display).

When Z is relative is activated the current Z position is automatically made the reference. To use an other Z position as the reference, move the stage to that Z position and press the Z = 0 button.

Z = 0

Pressing the Z = 0 button makes the current Z position the relative Z reference value.

4.56 Stage² Settings

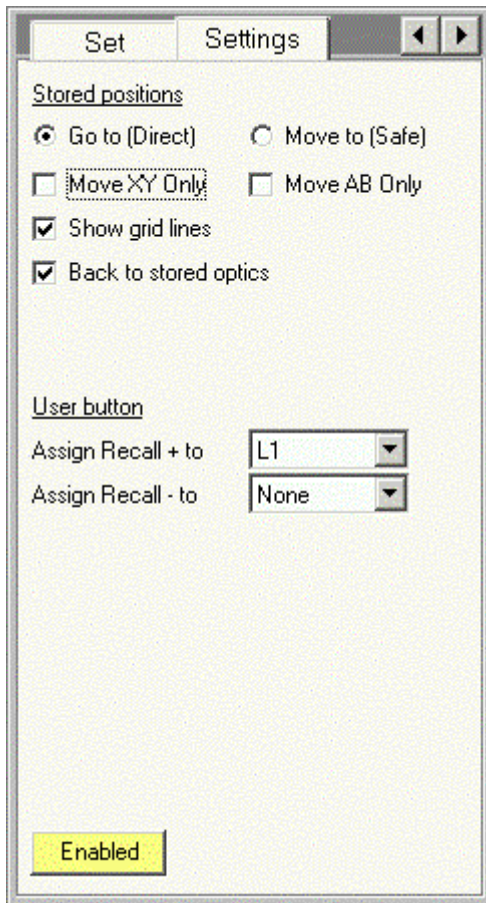

The Stage² Settings Control Panel.

The Stage² Settings Control Panel provides access to a number of Stage² options and the function for enabling/disabling the CompuStage.

Specimen-stage Move To's and Go To's

There are two different types of specimen-stage movements (apart from the ones initiated by the trackball) : Move To's and Go To's. The difference between these two is in the procedure followed by the specimen-stage to reach the new position. With Go To's the specimen stage will move on all axes (as far as necessary) at the same time. This is the mode of movement used when the Go To or Undo buttons are pressed. The Go To is more direct and therefore faster than the Move To.

With Move To's a fixed procedure is used to enhance safety during movement (to remove the possibility altogether of a high-speed collision between the moving stage and a fixed part of the microscope). This fixed procedure consists of the following steps:

- Set β tilt to zero.
- Set α tilt to zero.
- Go to the new X, Y, Z position.
- Set α tilt to new value.
- Set β tilt to new value.

Some of these steps may be absent. For example if a single-tilt holder is used, the β tilt steps are omitted. Or if no new values for X and Y are entered, only a Z go to is done in the third step.

Note: The Move To method is strongly advised if large specimen-stage movements are made.

Go To / Move To

Defines the type of movement used for recalling stored stage positions. This setting is stored and automatically recalled when closing and re-opening the Tecnai user interface.

Move XY Only

When checked, this option will result in move only to the X,Y values of stored stage positions (thus ignoring Z, a and b). This setting is stored and automatically recalled when closing and re-opening the Tecnai user interface.

Move AB Only

When checked, this option will result in move only to the a,b values of stored stage positions (thus ignoring X, Y and Z). This setting is stored and automatically recalled when closing and re-opening the Tecnai user interface.

Show grid lines

When checked, the display shows grid lines at 200 um (stage coordinates) intervals. This setting is stored and automatically recalled when closing and re-opening the Tecnai user interface.

Back to stored optics

When checked, this setting result in restoring of the optics settings together with the stored stage position, as a result of Go or double-click on the display. This setting is stored and automatically recalled when closing and re-opening the Tecnai user interface.

User button Recall +

The This setting is stored and automatically recalled when closing and re-opening the Tecnai user interface.

User button recall -

The This setting is stored and automatically recalled when closing and re-opening the Tecnai user interface.

Enabled

The Goniometer enabled option allows switching the CompuStage off in case it is on (the Gonio enabled button is yellow) or on when it is off.

Note: If the CompuStage is switched off and on, it needs to be homed before it can move. The homing procedure requires removal of the specimen holder.

4.57 Stage

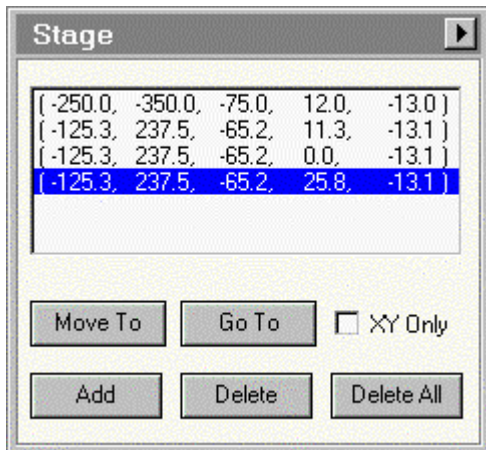

The Stage Control Panel.

The Stage Control Panel displays and allows control over specimen-stage positions. The positions stored can be saved to (or loaded) from file using the Stage File control panel in the Stage Control panel flap-out.

Please note: The Stage control panel is obsolete. it has been superseded by the Stage² Control Panel. You are advised to remove the 'old' control panel in Workspace layout and replace it by the new Stage² Control Panel.

Position list

The position list displays the specimen-stage positions stored. The list shows columns with X, Y, Z, a and b values (the latter only in case of a double-tilt holder). Positions can be added, deleted, saved in or reloaded from file, and moved to. Positions are selected by clicking with the mouse (or, if the list has the Windows focus - that is, it is the last Windows item used - the arrow keys of the keyboard can also be used to step through the list).

Move to

Instructs the specimen stage to move to the position currently highlighted in the position list.

Note: The Move To method is strongly advised if large specimen-stage movements are made.

Go to

Instructs the specimen stage to go to the position currently highlighted in the position list.

Add

Adds the current specimen-stage position to the position list.

Delete

Deletes the currently highlighted position in the position list.

Delete All

Deletes all positions in the position list. Requires confirmation.

XY only

Move To's and Go To's can be done for all five axes together or only for XY. The check box XY only defines which of these methods will be used (XY only on means that only X and Y will be changed). An example of the use of the all-axes method would be tilting to different zone axes on a single crystal, whereas XY only could be used to move to different X-Y positions stored at the currently active tilt settings.

Stage flap-out

Pressing the arrow button displays the flap-out containing the Control, Set, File and Enable control panels.

4.57.1 Specimen-stage Move To's and Go To's

There are two different types of specimen-stage movements (apart from the ones initiated by the trackball): **Move To's** and **Go To's**. The difference between these two is in the procedure followed by the specimen stage to reach the new position. With Go To's the specimen stage will move on all axes (as far as necessary) at the same time. This is the mode of movement used when the Go To or Undo buttons are pressed. The Go To is more direct and therefore faster than the recall.

With Move To's a fixed procedure is used to enhance safety during movement (to remove the possibility altogether of a high-speed collision between the moving stage and a fixed part of the microscope). This fixed procedure consists of the following steps:

- Set b tilt to zero.
- Set a tilt to zero.
- Go to the new X, Y, Z position.
- Set a tilt to new value.
- Set b tilt to new value.

Some of these steps may be absent. For example if a single-tilt holder is used, the b tilt steps are omitted. Or if no new values for X and Y are entered, only a Z go to is done in the third step.

Note: The Move To method is strongly advised if large specimen-stage movements are made.

4.58 Stage Control

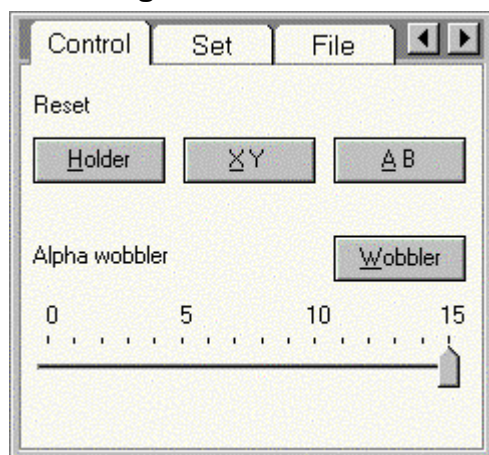

The Stage Control Control Panel.

The Stage Control Control Panel provides control over stage settings.

Reset holder to 0

Resets all axes to zero. It is advised to use this function (or at the very least Reset AB before removing a specimen holder from the microscope).

Reset XY to 0

Resets the XY position to 0,0.

Reset A (or AB) to 0

Reset the tilts to zero.

Wobbler

The Alpha wobbler tool helps in setting the eucentric height. When the wobbler is switched on (the button will turn yellow), the CompuStage will tilt continuously on a from minus to plus by the value set with the alpha wobbler track bar. By changing the Z height and minimizing the image movement, the CompuStage is set to the eucentric height.

Alpha wobbler

The alpha wobbler track bar sets the alpha wobble angle. The maximum value is 15 degrees (5 degrees for the U-TWIN lens), but the user can set any angle less than that.

4.59 Stage Enable

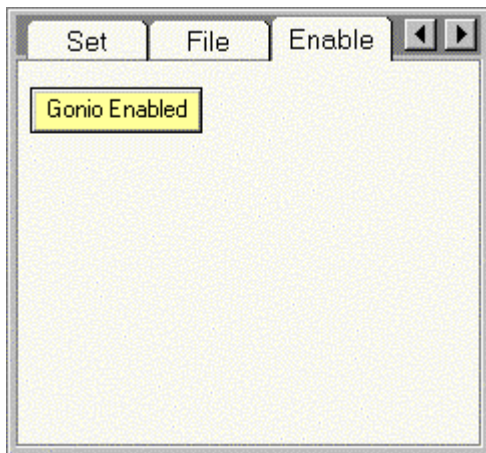

The Stage Enable Control Panel.

The Stage Enable Control Panel provides a control for enabling/disabling the CompuStage.

Goniometer enabled

The Goniometer enabled option allows switching the CompuStage off in case it is on (the Gonio Enabled button is yellow) or on when it is off.

Note: If the CompuStage is switched off and on, it needs to be homed before it can move. The homing procedure requires removal of the specimen holder.

4.60 Stage File

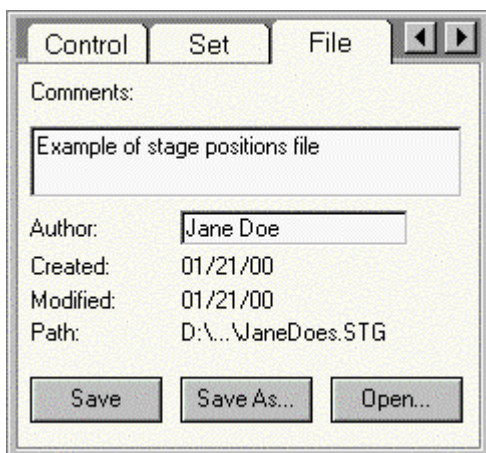

The Stage File Control Panel.

The Stage File Control Panel allows saving and reloading of stage positions to and from file. The positions are those as listed in the positions list of the Stage Control Panel.

Comments

Comments can be added to files with specimen-stage positions.

Author

The name of an author (the person storing the positions and saving the file) can be added to the files with specimen-stage positions.

Created, modified, path

Specimen-stage positions files keep track of their original date of saving (created), the date of any later changes saved and the name of the file.

Save

When the Save button is pressed, the specimen-stage positions are stored in a file. If a filename had been defined previously (through either Save, Save As or Open), that is the file under which the positions will be saved. If no filename has been defined yet, a standard Save File dialog will come up, where a filename (and folder) can be set.

Save As

When the Save button is pressed, a standard Save File dialog will come up, where a filename (and folder) can be set. The current positions list will be saved in that file.

Open

When the Open button is pressed, a standard Open File dialog will come up, where a file can be selected for reloading. The current positions list will be cleared and the positions from the file entered in the list.

4.61 Stage Set

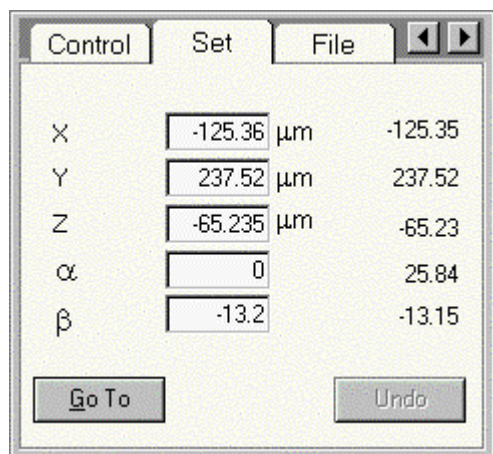

The Stage Set Control Panel.

The Stage Set Control Panel allows control over specimen-stage positions by entering stage-axis values.

X position

The specimen-stage X position defines the value (in mm) for the new specimen-stage position set after the Go To button is pressed. If no value is entered for X, the current X position remains unchanged.

Y position

The specimen-stage Y position defines the value (in mm) for the new specimen-stage position set after the Go To button is pressed. If no value is entered for Y, the current Y position remains unchanged.

Z position

The specimen-stage Z position defines the value (in mm) for the new specimen-stage position set after the Go To button is pressed. If no value is entered for Z, the current Z position remains unchanged.

a tilt

The specimen-stage a tilt defines the value (in degrees) for the new specimen-stage position set after the Go To button is pressed. If no value is entered to a, the current a tilt remains unchanged.

b tilt

The specimen-stage b tilt defines the value (in degrees) for the new specimen-stage position set after the Go To button is pressed. If no value is entered to b, the current b tilt remains unchanged. The b is only available (visible) if a double-tilt holder is used.

Current position

The current specimen-stage position is listed on the right.

Go to

When the specimen-stage position Go To button is pressed, the specimen-stage is instructed to go to the position as defined by the four (X, Y, Z, a) or five (X, Y, Z, a, b) position edit controls. The button remains disabled until at least one value for a new stage position has been entered. If no value has been entered for a particular axis, the setting of that axis will remain unchanged in the Go To.

The Go To button and the Undo button turn gray as long as the specimen-stage has not yet reached the new position.

Specimen-stage Move To's and Go To's

There are two different types of specimen-stage movements (apart from the ones initiated by the trackball): **Move To's** and **Go To's**. The difference between these two is in the procedure followed by the specimen-stage to reach the new position. With Go To's the specimen-stage will move on all axes (as far as necessary) at the same time. This is the mode of movement used when the Go To or Undo buttons are pressed. The Go To is more direct and therefore faster than the recall.

- With Move To's a fixed procedure is used to enhance safety during movement (to remove the possibility altogether of a high-speed collision between the moving stage and a fixed part of the microscope). This fixed procedure consists of the following steps:
 - Set b tilt to zero.
- Set a tilt to zero.
- Go to the new X, Y, Z position.
- Set a tilt to new value.
- Set b tilt to new value.

Some of these steps may be absent. For example if a single-tilt holder is used, the b tilt steps are omitted. Or if no new values for X and Y are entered, only a Z go to is done in the third step.

Note: The Move To method is strongly advised if large specimen-stage movements are made.

Undo

When the Undo button is pressed, the specimen-stage returns to the last position set by a Go To. For safety the procedure followed by the specimen-stage when the Undo button is pressed is a Move To.

The Undo button and the Go To button turn gray as long as the specimen-stage has not yet reached the previous position.

4.62 STEM Imaging (User)

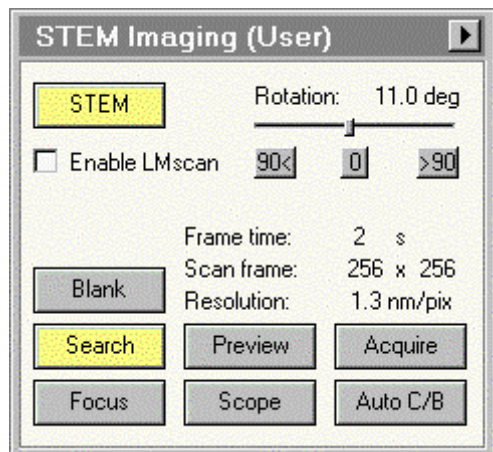

The STEM Imaging Control Panel.

The STEM Imaging Control Panel contains the most important STEM controls. For a description of the basic concept of scanning, see the STEM mode description. The details of scanning operation itself are described separately.

For easy operation, the scanning system has three preset modes with their own buttons, Search, Preview and Acquire. Each of the three can have its own, separate scanning settings (Frame size, Frame Time), allowing rapid switching between different settings. The actual settings are up to the user. Typical settings could be:

- Search: Frame size 256*256, Frame time 1 second.
- Preview: Frame size 512*512, Frame time 5 seconds.
- Acquire: Frame size 1024*1024, Frame time 30 to 60 seconds.

By definition Search and Preview are continuous acquisition, while Acquire acquires a single frame and stops (to allow the operator to save the image).

The Focus state is different from the previous three settings. It will display a small window inside an image already collected. Only the image inside the frame is then collected and updated. The frame can be moved around and changed in size to select an area more suitable for focusing.

STEM

The STEM button switches the Tecnai microscope to the STEM mode (the button becomes yellow) and back (the button becomes gray).

Scan rotation

The scanning image can be rotated continuously. Click on the trackbar and drag the handle to left or right to change the scan rotation or (as long as the trackbar has the Windows focus - denoted by the dashed lines around it), use the arrow keys on the keyboard to change the rotation angle. When the button 0 is pressed, the scan rotation is reset to 0°. When the buttons 90< and >90 are pressed, the scan rotation is changed 90° from its current setting to left or right.

Enable LMscan

By default, the STEM system will not switch to LM scanning (in which the objective lens is off) when the operator turns the magnification further down than the lowermost scanning magnification step. If you want to go to LM scanning, the checkbox must first be checked. Only then is it possible to change to LM scanning by turning the magnification knob further down. The checkbox is reset to the default (off) each time STEM is switched off and on.

Frame time

The Frame time indicates the time a single frame will require for the currently active viewing mode (Search, Preview, Acquire).

Scan frame / resolution

The Scan frame and resolution values indicate the settings of the currently active viewing mode (Search, Preview, Acquire). The two parameters are linked but give different types of information. The scan frame indicates the size in pixels of the image collected, whereas the resolution indicates how large a single pixel is. The latter value is a useful indication for selecting spot size. For example, if the spot size used on the microscope is much larger than the indicated resolution, then the resolution in the image will be wholly determined by the microscope's spot size. If on the other hand, the indicated resolution is much larger than the spot size, the spot size could be increased to give better signal without loss of resolution.

Blank

The STEM Imaging Control Panel provides a function for blanking of the electron beam to avoid beam damage of other undesired effects when the beam remains on a fixed location of the specimen (that is, while it is not scanning). The beam is blanked then the button is yellow.

Note 1: The unblanking of the beam is not instantaneous and may take a short while to become effective. If a scan is started too quickly after unblanking of the beam the start of the image may look distorted.

Note 2: The microscope does not check that the beam is unblanked when a scan is started. It is entirely up to the user to make sure that the electron beam can reach the specimen when needed. Only when STEM is stopped or the user interface closed is the beam blanking switched off automatically.

Search

Pressing the Search button:

- When the button is gray, switches the scan settings to those of the Search mode and starts scanning.
- When the button is yellow, pauses the scan acquisition.
- When the button is white, resumes the scan acquisition (but starting with a new frame) if possible. If the start command could not be given to TIA, the button will remain white.

By definition Search is continuous acquisition. The scan parameters are set in the STEM Imaging Scan Control Panel.

Preview

Pressing the Preview button:

- When the button is gray, switches the scan settings to those of the Preview mode and starts scanning.
- When the button is yellow, pauses the scan acquisition.
- When the button is white, resumes the scan acquisition (but starting with a new frame) if possible. If the start command could not be given to TIA, the button will remain white.

By definition Preview is continuous acquisition. The scan parameters are set in the STEM Imaging Scan Control Panel.

Acquire

Pressing the Acquire button:

- When the button is gray, switches the scan settings to those of the Acquire mode and starts acquisition.
- When the button is yellow, pauses the scan acquisition.
- When the button is white, resumes the scan acquisition (but starting with a new frame) if possible. If the start command could not be given to TIA, the button will remain white.

By definition Acquire acquires a single frame and stops (to allow the operator to save the image). The scan parameters are set in the STEM Imaging Scan Control Panel.

Focus

Pressing the Focus button activates (button becomes yellow) or stops (button becomes gray) the acquisition of the Focus image. When active, the Focus window is displayed in the center of the STEM image. Only the area inside the Focus window is now scanned, the remainder of the image is 'frozen'.

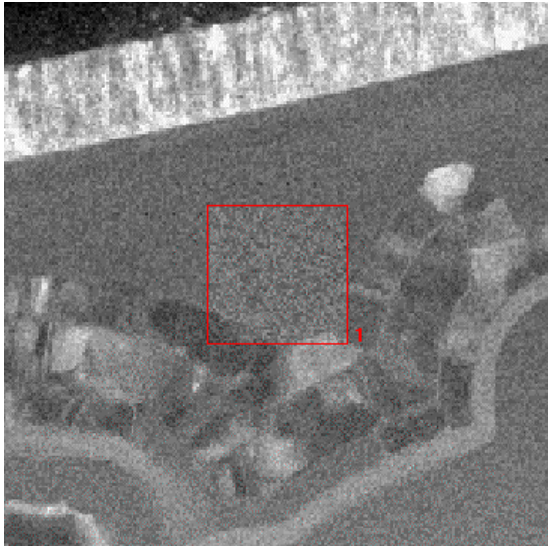

Part of a STEM image with the Focus window in the center.

The Focus window can be moved around or changed in size by clicking on it with the left-hand mouse button and dragging between the handles (small squares at corners and centers of the lines) to move it around or dragging a handle to change the size. The focus parameters are set in the STEM Imaging Focus Control Panel.

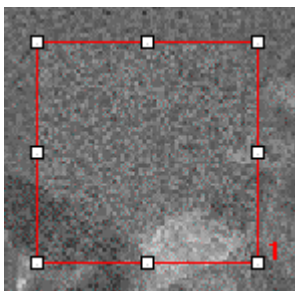

The Focus window with handles to change its position or size.

Scope

The Scope button enables or disables acquisition of images with a videoscope signal displayed as well. The videoscope signal shows the full range of signal levels available and the video levels along the lines of the scan. When scan acquisition is not active the scope signal shows the video levels along a line in the center of the image.

Auto CB

Press Auto CB to instruct the system to optimize the Contrast and Brightness of the detector selected automatically. The Auto Contrast Brightness function will repeatedly collect an image, determine its range of video levels (for a selected number of points), and adjust the contrast and brightness settings of the detector, until the contrast and brightness are optimized.

Flap-out

Pressing the arrow button displays the flap-out with the STEM Imaging Scan and Focus Control Panels.

4.63 STEM Imaging Focus (User)

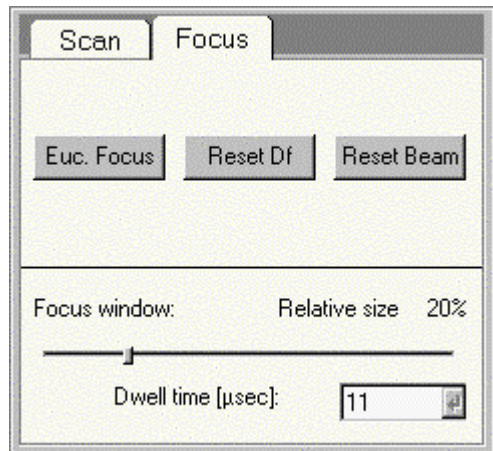

The STEM Imaging Focus Control Panel.

In the STEM Imaging Focus Control Panel various parameters related to focusing in STEM are controlled.

Euc. focus

Pressing the Euc. focus button executes the Eucentric focus function. In the case of STEM, this function sets the intensity and objective-lens currents to their (pre-aligned) value for focus at the eucentric height and normalizes the lenses.

Note: the eucentric focus only sets the objective lens for the eucentric height, not the specimen itself (if the specimen is off the eucentric height, it will then appear out of focus).

Reset Df

Pressing the Reset Df button reset the Defocus display value to 0.

Reset beam

Pressing the reset beam button reset the user beam shift setting (as set with the trackball) to 0.

Focus window

The Focus window parameters defines the size of the Focus window relative to the STEM image.

Dwell time

The dwell time parameters defines the dwell time (the amount of time the beam resides at a pixel) for the Focus function.

4.64 STEM Imaging Scan (User)

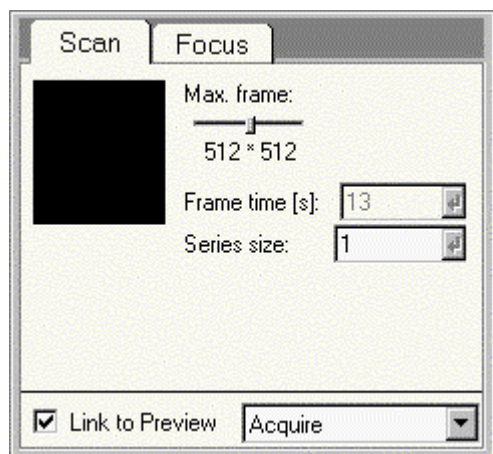

The Scanning Scan Control Panel.

In the Scanning Scan Control Panel the scan parameters are defined.

Max. frame

The maximum frame parameter defines the size of the scan frame for the currently selected acquisition mode.

Frame time

The Frame time for the scan frame is set by changing the value in the spin-enter-edit control. Press the Enter button to set the value.

Series size

Under Series size the number of images acquired in a TIA series is defined.

Link to Preview

The Acquire acquisition mode settings can be defined as totally independent or they can be linked to the Preview settings. In the latter case, any change in the Preview settings (frame time, etc.) will automatically be used in Acquire as well (the typical difference then being that Preview is continuous acquisition while Acquire results in a single image).

Acquisition mode

In the acquisition mode drop-down list, the acquisition mode for which the parameters must be defined, can be selected. The difference between selecting the acquisition mode through the drop-down list and by pressing the equivalent button in the main control panel is that the drop-list selection selects the mode but does not automatically start acquisition.

4.65 STEM Imaging (Expert)

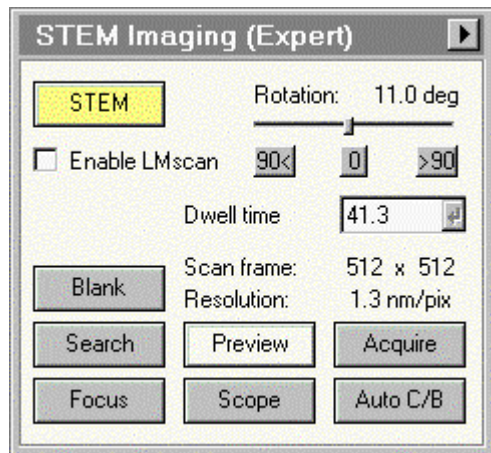

The STEM Imaging Control Panel.

The STEM Imaging Control Panel contains the most important STEM controls. For a description of the basic concept of scanning, see the STEM mode description. The details of scanning operation itself are described separately.

For easy operation, the scanning system has three preset modes with their own buttons, Search, Preview and Acquire. Each of the three can have its own, separate scanning settings (Frame size, Frame Time), allowing rapid switching between different settings. The actual settings are up to the user. Typical settings could be:

- Search: Frame size 256*256, Frame time 1 second.
- Preview: Frame size 512*512, Frame time 5 seconds.
- Acquire: Frame size 1024*1024, Frame time 30 to 60 seconds.

By definition Search and Preview are continuous acquisition, while Acquire acquires a single frame and stops (to allow the operator to save the image).

The Focus state is different from the previous three settings. It will display a small window inside an image already collected. Only the image inside the frame is then collected and updated. The frame can be moved around and changed in size to select an area more suitable for focusing.

STEM

The STEM button switches the Tecnai microscope to the STEM mode (the button becomes yellow) and back (the button becomes gray).

Scan rotation

The scanning image can be rotated continuously. Click on the trackbar and drag the handle to left or right to change the scan rotation or (as long as the trackbar has the Windows focus - denoted by the dashed lines around it), use the arrow keys on the keyboard to change the rotation angle. When the button 0 is pressed, the scan rotation is reset to 0°. When the buttons 90< and >90 are pressed, the scan rotation is changed 90° from its current setting to left or right.

Enable LMscan

By default, the STEM system will not switch to LM scanning (in which the objective lens is off) when the operator turns the magnification further down than the lowermost scanning magnification step. If you want to go to LM scanning, the checkbox must first be checked. Only then is it possible to change to LM scanning by turning the magnification knob further down. The checkbox is reset to the default (off) each time STEM is switched off and on.

Dwell time

The Dwell time indicates the time needed for acquisition of a single pixel for the currently active viewing mode (Search, Preview, Acquire).

Scan frame / resolution

The Scan frame and resolution values indicate the settings of the currently active viewing mode (Search, Preview, Acquire). The two parameters are linked but give different types of information. The scan frame indicates the size in pixels of the image collected, whereas the resolution indicates how large a single pixel is. The latter value is a useful indication for selecting spot size. For example, if the spot size used on the microscope is much larger than the indicated resolution, then the resolution in the image will be wholly determined by the microscope's spot size. If on the other hand, the indicated resolution is much larger than the spot size, the spot size could be increased to give better signal without loss of resolution.

Blank

The STEM Imaging Control Panel provides a function for blanking of the electron beam to avoid beam damage of other undesired effects when the beam remains on a fixed location of the specimen (that is, while it is not scanning). The beam is blanked then the button is yellow.

Note 1: The unblanking of the beam is not instantaneous and may take a short while to become effective. If a scan is started too quickly after unblanking of the beam the start of the image may look distorted.

Note 2: The microscope does not check that the beam is unblanked when a scan is started. It is entirely up to the user to make sure that the electron beam can reach the specimen when needed. Only when STEM is stopped or the user interface closed is the beam blanking switched off automatically.

Search

Pressing the Search button:

- When the button is gray, switches the scan settings to those of the Search mode and starts scanning.
- When the button is yellow, pauses the scan acquisition.
- When the button is white, resumes the scan acquisition (but starting with a new frame) if possible. If the start command could not be given to TIA, the button will remain white.

By definition Search is continuous acquisition. The scan parameters are set in the STEM Imaging Scan Control Panel.

Preview

Pressing the Preview button:

- When the button is gray, switches the scan settings to those of the Preview mode and starts scanning.
- When the button is yellow, pauses the scan acquisition.
- When the button is white, resumes the scan acquisition (but starting with a new frame) if possible. If the start command could not be given to TIA, the button will remain white.

By definition Preview is continuous acquisition. The scan parameters are set in the STEM Imaging Scan Control Panel.

Acquire

Pressing the Acquire button:

- When the button is gray, switches the scan settings to those of the Acquire mode and starts acquisition.
- When the button is yellow, pauses the scan acquisition.
- When the button is white, resumes the scan acquisition (but starting with a new frame) if possible. If the start command could not be given to TIA, the button will remain white.

By definition Acquire acquires a single frame and stops (to allow the operator to save the image). The scan parameters are set in the STEM Imaging Scan Control Panel.

Focus

Pressing the Focus button activates (button becomes yellow) or stops (button becomes gray) the acquisition of the Focus image. When active, the Focus window is displayed in the center of the STEM image. Only the area inside the Focus window is now scanned, the remainder of the image is 'frozen'.

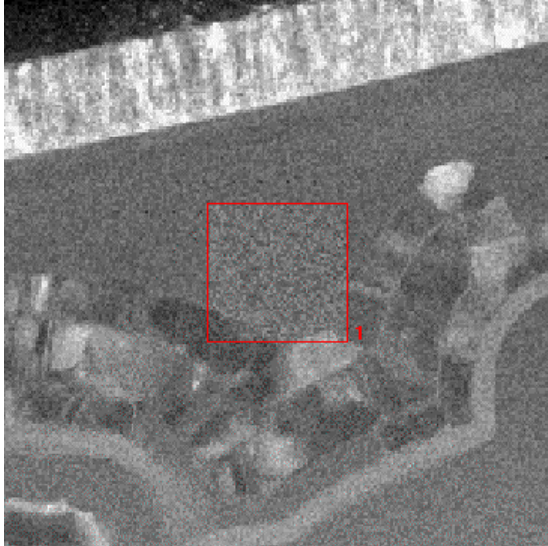

Part of a STEM image with the Focus window in the center.

The Focus window can be moved around or changed in size by clicking on it with the left-hand mouse button and dragging between the handles (small squares at corners and centers of the lines) to move it around or dragging a handle to change the size. The focus parameters are set in the STEM Imaging Focus Control Panel.

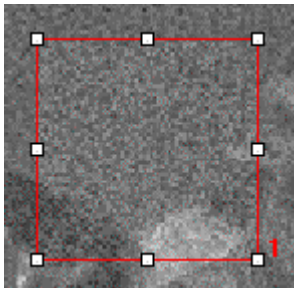

The Focus window with handles to change its position or size.

Scope

The Scope button enables or disables acquisition of images with a videoscope signal displayed as well. The videoscope signal shows the full range of signal levels available and the video levels along the lines of the scan. When scan acquisition is not active the scope signal shows the video levels along a line in the center of the image.

Auto CB

Press Auto CB to instruct the system to optimize the Contrast and Brightness of the detector selected automatically.

Flap-out

Pressing the arrow button displays the flap-out with the STEM Imaging Scan and Focus Control Panels.

4.66 STEM Imaging Focus (Expert)

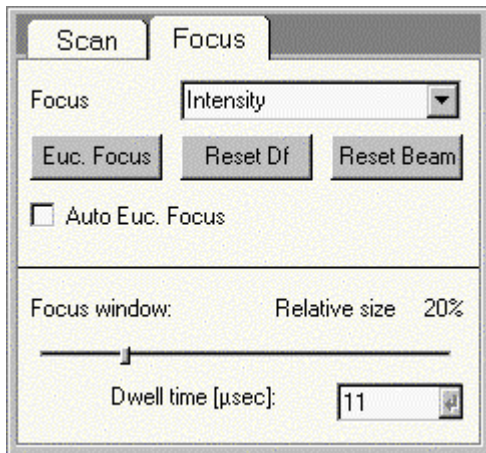

The STEM Imaging Focus Control Panel.

In the STEM Imaging Focus Control Panel various parameters related to focusing in STEM are controlled.

Focus

The selection of the Focus drop-down list defines how the operator wants to focus in STEM imaging. Possible choices are:

- Intensity - the default setting, the same as the normal user, with the Focus knob controlling the Intensity setting, the objective-lens fixed and the Intensity knob decoupled.
- Objective - the Focus knob controls the Objective-lens setting and the Intensity is fixed, with the Intensity knob decoupled.
- Step-size dependent - the microscope automatically changes the Objective-lens setting for small focusing steps and the Intensity setting for larger focusing steps, both from the Focus knob, while the Intensity knob is decoupled.
- Intensity and objective - both Intensity and Objective-lens setting can be controlled freely, with the Focus knob controlling the Objective-lens setting and the Intensity knob the Intensity setting.

Euc. focus

Pressing the Euc. focus button executes the Eucentric focus function. In the case of STEM, this function sets the intensity and objective-lens currents to their (pre-aligned) value for focus at the eucentric height and normalizes the lenses.

Note: the eucentric focus only sets the objective lens for the eucentric height, not the specimen itself (if the specimen is off the eucentric height, it will then appear out of focus).

Auto Euc. focus

If the Auto Euc. focus checkbox is checked, the microscope will execute the Eucentric focus function each time when the STEM mode is entered (to reset the focusing conditions to good default values).

Reset Df

Pressing the Reset Df button reset the Defocus display value to 0.

Reset beam

Pressing the reset beam button reset the user beam shift setting (as set with the trackball) to 0.

Focus window

The Focus window parameters defines the size of the Focus window relative to the STEM image.

Dwell time

The dwell time parameters defines the dwell time (the amount of time the beam resides at a pixel) for the Focus function.

4.67 STEM Imaging Scan (Expert)

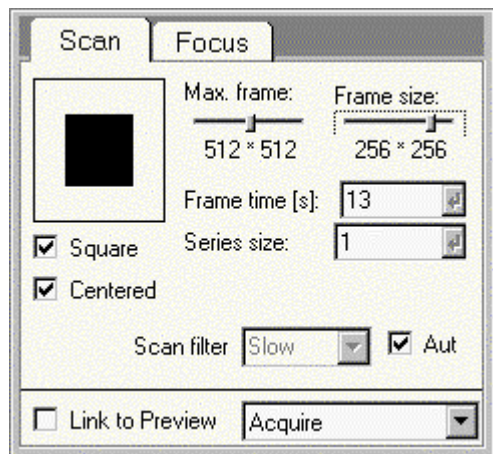

The STEM Imaging Scan Control Panel.

In the STEM Imaging Scan Control Panel the scan parameters are defined.

Scan frame

The scan frame is a graphic representation of the frame size that allows setting of frame-size parameters with the mouse.

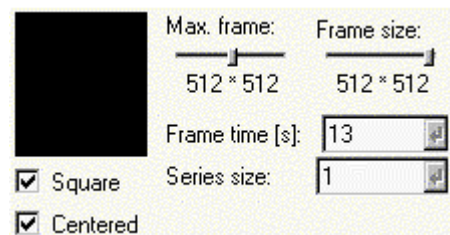

When the Max. frame and Frame size are equal, the scan frame fills the full frame.

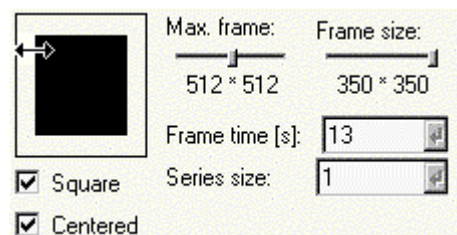

Move the cursor to the edge of the scan frame. It will change to a Resize cursor (horizontal, vertical or diagonal, depending on the cursor position relative to the frame). Click with the left-hand mouse button and drag to change the size of the scan frame.

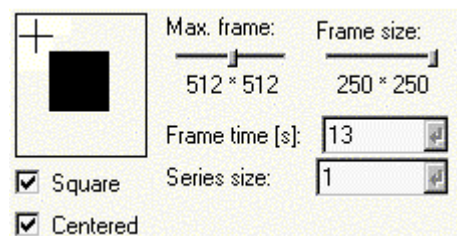

If the scan frame is smaller than the full frame, the cursor will change to the Precision select cursor inside the full frame but outside the scan frame. Click with the left-hand mouse button and the frame size will 'jump' to the cursor positions. Drag to adjust the scan frame.

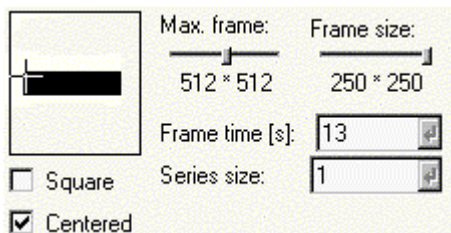

If square is not checked, the cursor position inside the full frame will determine the scan frame dimensions in x and y as well.

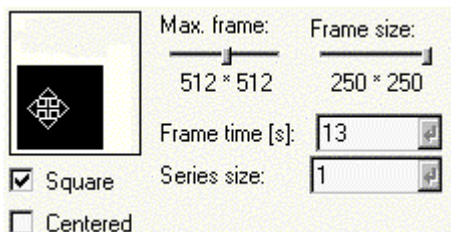

When centered is not checked, the cursor will change to the Move cursor when it is inside the black rectangle representing the scan frame. Click with the left-hand mouse button on the frame and drag it to any position within the full frame.

Max. frame

The Max. frame sets the number of pixels (in powers of 2) for the maximum scan range for the currently selected acquisition mode.

Frame size

The Frame size parameter determines the actual size of the scan frame. The value of the Frame size can be anywhere from the Resolution values downwards. To reset the Frame size to power of 2 values, drag the slider fully to the right and it will clip at the Resolution value. The Square and Centered checkboxes will be checked automatically.

Square

When Square is checked, the scan frame is forced to be square (x and y dimensions equal). Otherwise the scan frame can have any (rectangular) shape.

Centered

When Centered is checked, the scan frame is forced to remain centered within the full frame. Otherwise the scan frame can be positioned anywhere within the full frame.

Scan filters

Not functional on LaB₆ systems (AC filters are present on FEG microscopes only).

Frame time

The Frame time for the scan frame is set by changing the value in the spin-enter-edit control. Press the Enter button to set the value.

Series size

Under Series size the number of images acquired in a TIA series is defined.

Link to Preview

The Acquire acquisition mode settings can be defined as totally independent or they can be linked to the Preview settings. In the latter case, any change in the Preview settings (frame time, etc.) will automatically be used in Acquire as well (the typical difference then being that Preview is continuous acquisition while Acquire results in a single image).

Acquisition mode

In the acquisition mode drop-down list, the acquisition mode for which the parameters must be defined, can be selected. The difference between selecting the acquisition mode through the drop-down list and by pressing the equivalent button in the main control panel is that the drop-list selection selects the mode but does not automatically start acquisition.

4.68 STEM Detector (User)

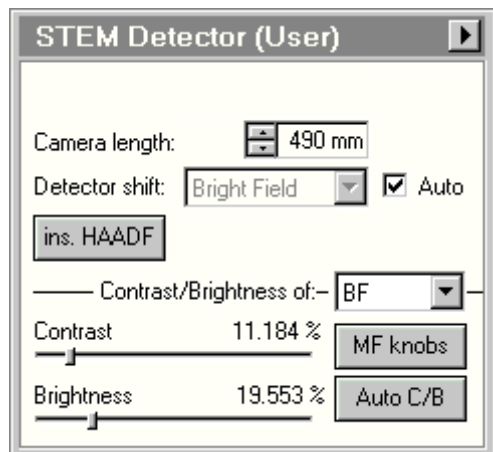

The STEM Detector Control Panel.

In the STEM Detector Control Panel various detector settings are controlled.

Camera length

The camera length for STEM is set with the spin buttons (there is no other way to control the camera length in STEM because the magnification knob is coupled to the STEM magnification).

Detector shift

The detector shift controls if and where to the diffraction pattern is shifted. In automatic mode (Auto checkbox checked), the setting will be done on the basis of the detector selected (and only if the screen is up).

ins HAADF

Pressing the ins HAADF button inserts or retracts the HAADF detector (only when present).

Contrast / Brightness of ...

In the drop-down list box after Contrast / Brightness of is selected which detector is controlled by the functions underneath (Contrast and Brightness track bars, MF knob control and Auto CB).

Contrast

With the Contrast track bar the contrast (gain) setting of the detector is controlled.

Brightness

With the Brightness track bar the brightness (offset) setting of the detector is controlled.

MF knobs

Press MF knobs to couple the Multifunction X and Y knobs to the contrast and brightness settings of the detector.

Auto C/B

Press Auto CB to instruct the system to optimize the Contrast and Brightness of the detector selected automatically. The Auto Contrast Brightness function will repeatedly collect an image, determine its range of video levels (for a selected number of points), and adjust the contrast and brightness settings of the detector, until the contrast and brightness cover specified levels.

Flap-out

Pressing the arrow button displays the flap-out containing the STEM Detector Selection Control Panel.

4.69 STEM Detector Selection (User)

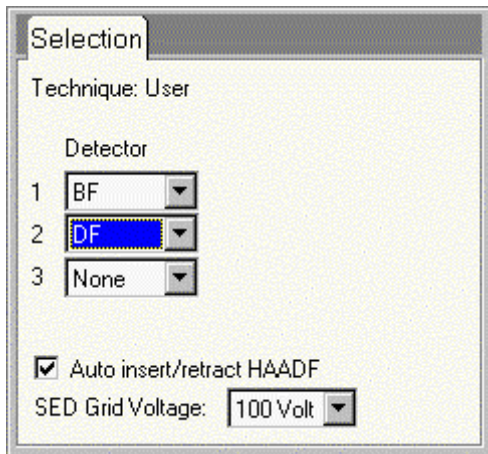

The STEM Detector Selection Control Panel.

In the STEM Detector Selection Control Panel the STEM detector(s) to be used are selected and some other detector parameters are defined.

Detector

Each of the STEM detectors present can be selected in the drop-down lists (each list represents a video channel). The detectors selected determine which images are displayed in TIA during scanning (all lists in which a detector signal is selected will be displayed). At any particular time only two signals can be selected (for simultaneous acquisition), though the TIA acquisition window may contain more images from other detectors (acquired previously).

Auto insert/retract HAADF

The Auto insert/retract HAADF determines whether the HAADF detector is automatically inserted or retracted when appropriate. If not checked, the detector must be inserted or retracted by hand (operator instruction).

This control is only present when a HAADF detector is present.

SED Grid Voltage

The SED Grid Voltage setting defines the voltage on the Secondary Electron Detector extraction anode (an anode located just below the upper objective-lens pole piece; on some systems integrated with the Backscattered Electron Detector). The extraction anode allows selection of various ranges of SED energies. If the grid voltage is positive, all secondary electrons are attracted (with the strength of the grid voltage determining how strongly the secondary electrons are attracted). If the grid voltage is negative, low-energy secondary electrons (the bulk of the secondary electrons have energies below 50 eV) are repelled and the image of the SE detector becomes increasingly dominated by backscattered electrons. This control is only present when an SE detector is present.

4.70 STEM Detector (Expert)

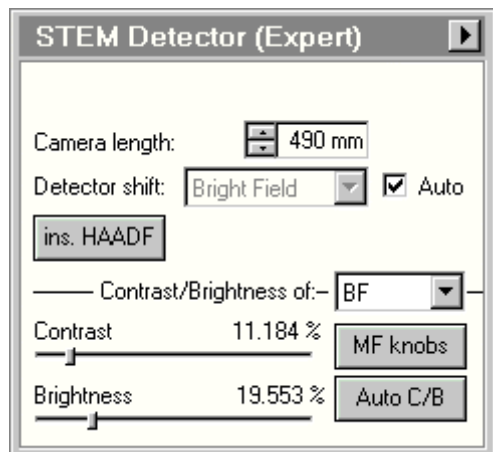

The STEM Detector Control Panel.

In the STEM Detector Control Panel various detector settings are controlled.

Camera length

The camera length for STEM is set with the spin buttons (there is no other way to control the camera length in STEM because the magnification knob is coupled to the STEM magnification).

Detector shift

The detector shift controls if and where to the diffraction pattern is shifted. In automatic mode (Auto checkbox checked), the setting will be done on the basis of the detector selected (and only if the screen is up).

ins HAADF

Pressing the ins HAADF button inserts or retracts the HAADF detector (only when present).

Contrast / Brightness of ...

In the drop-down list box after Contrast / Brightness of is selected which detector is controlled by the functions underneath (Contrast and Brightness track bars, MF knob control and Auto CB).

Contrast

With the Contrast track bar the contrast (gain) setting of the detector is controlled.

Brightness

With the Brightness track bar the brightness (offset) setting of the detector is controlled.

MF knobs

Press MF knobs to couple the Multifunction X and Y knobs to the contrast and brightness settings of the detector.

Auto C/B

Press Auto CB to instruct the system to optimize the Contrast and Brightness of the detector selected automatically. The Auto Contrast Brightness function will repeatedly collect an image, determine its range of video levels (for a selected number of points), and adjust the contrast and brightness settings of the detector, until the contrast and brightness cover specified levels.

Flap-out

Pressing the arrow button displays the flap-out containing the STEM Detector Selection Control Panel.

4.71 STEM Detector Selection (Expert)

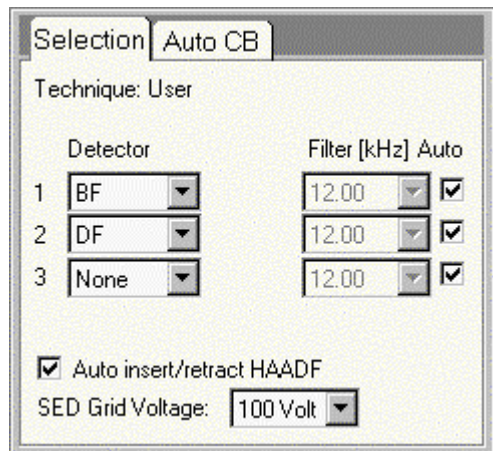

The STEM Selection Control Panel.

In the STEM Selection Control Panel the STEM detector(s) to be used are selected and some other detector parameters are defined.

Detector

Each of the STEM detectors present can be selected in the drop-down lists (each list represents a video channel). The detectors selected determine which images are displayed in TIA during scanning (all lists in which a detector signal is selected will be displayed). At any particular time only two signals can be selected (for simultaneous acquisition), though the TIA acquisition window may contain more images from other detectors (acquired previously).

Filter

The Filter defines the setting of the video filter, each for the channel to the left of it. Normally these can be kept on automatic control. There is a range of manual settings, selectable from the drop-down lists (which are enabled only if the Auto checkbox is unchecked; otherwise the settings is adjusted automatically, dependent on the scan speed). In manual control the correct filter setting can be determined by starting with a high value and lowering it until the image starts to have horizontal streaks (signal variations are smeared out over several pixels). Increase the value again by approximately two steps (or at least until the streaks are completely absent).

Auto insert/retract HAADF

The Auto insert/retract HAADF determines whether the HAADF detector is automatically inserted or retracted when appropriate. If not checked, the detector must be inserted or retracted by hand (operator instruction).

This control is only present when a HAADF detector is present.

SED Grid Voltage

The SED Grid Voltage setting defines the voltage on the Secondary Electron Detector extraction anode (an anode located just below the upper objective-lens pole piece; on some systems integrated with the Backscattered Electron Detector). The extraction anode allows selection of various ranges of SED energies. If the grid voltage is positive, all secondary electrons are attracted (with the strength of the grid voltage determining how strongly the secondary electrons are attracted). If the grid voltage is negative, low-energy secondary electrons (the bulk of the secondary electrons have energies below 50 eV) are repelled and the image of the SE detector becomes increasingly dominated by backscattered electrons. This control is only present when an SE detector is present.

4.72 STEM Detector Auto CB

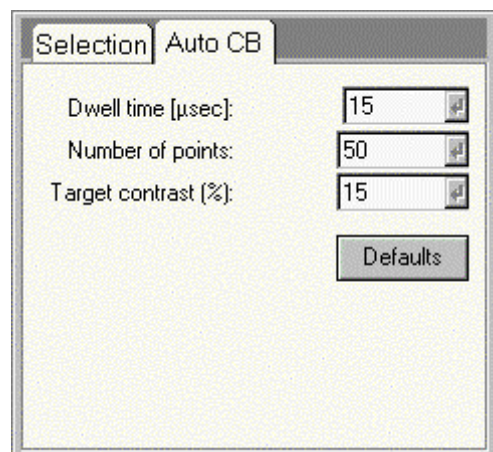

The STEM Detector Auto CB Control Panel.

In the STEM Detector Auto CB Control Panel the settings used for the Auto Contrast Brightness function are defined. The Auto Contrast Brightness function will repeatedly collect an image, determine its range of video levels (for a selected number of points), and adjust the contrast and brightness settings of the detector, until the contrast and brightness cover the specified levels (contrast to the target contrast, brightness within the accessible range of video levels).

Dwell time

The dwell time defines the time per pixel for measuring the video level. Longer times lead to less noisy signal but increase the time necessary for the Auto Contrast Brightness function to finish.

Number of points

The number of points determines at how many points the video level is measured for each cycle. Increasing the number of points increases the 'relevance' of the Auto Contrast Brightness function but also increases the cycle time. The points are distributed over a whole image. If the total range of video levels is spread out over a whole image with each level present in an area of reasonable size (more than just a few pixels), run the Auto Contrast Brightness function over the image as is. If, however, the video levels change on a small scale (as e.g. with small particles), increase the magnification so just a few particles are visible and/or increase the number of points before running the Auto Contrast Brightness function (otherwise the pixels used for measuring the video levels may miss the small features altogether).

Target contrast

The target contrast defines how much of the total available signal range should be filled by the detector signal. Thus 100% would have the lowest signal from the detector at 0 and the highest at 64000. Under normal circumstances a range of 10 to 15% is sufficient (the display software then automatically optimizes the image display from black to white).

Defaults

Press the Defaults button to reset all values to their default.

4.73 Stigmator

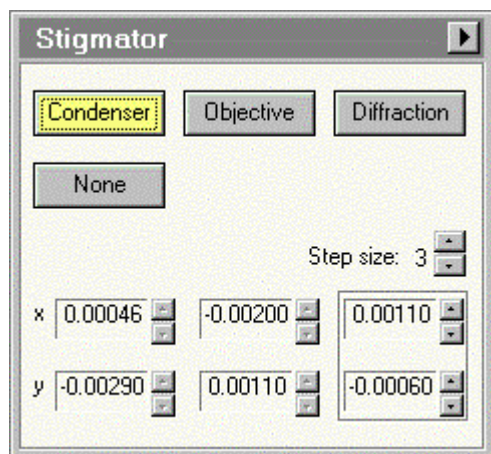

The Stigmator Control Panel.

The Stigmator Control Panel allows the operator to control the three stigmators of the microscope.

Condenser

The condenser stigmator is used to stigmatize the electron beam. It is the default stigmator for modes where the beam is important (like nanoprobe and STEM). Pressing the Condenser stigmator button is equivalent to pressing the Stigmator button on the left-hand control pad plus selecting the condenser stigmator.

Objective

The objective stigmator is used to stigmatize the HM (high-magnification) TEM image and the LAD (Low-Angle Diffraction) pattern. Pressing the Objective stigmator button is equivalent to pressing the Stigmator button on the left-hand control pad plus selecting the objective stigmator.

Diffraction

The diffraction stigmator is used to stigmatize the D (high-magnification) diffraction pattern and the LM (low-magnification) TEM image. Pressing the Diffraction stigmator button is equivalent to pressing the Stigmator button on the left-hand control pad plus selecting the diffraction stigmator.

None

The None button allows the operator to deselect all stigmators. Pressing None is equivalent to pressing the stigmator button on the left-hand control pad when it is on.

Step size

Each stigmator has its own step size. The step size determines the increment with which the stigmator is changed when the Multifunction buttons are turned or the spin buttons of the channels pressed. The step size is changed either with the spin buttons in the control panel or by pressing the +/- buttons left of the Multifunction-X knob on the left-hand control pad.

Channel

Stigmator settings can be stored in three channels. One possible use of the channels is to use them for optical modes that can be slightly different (such as SA and Mh magnifications, because of the small change in objective-lens current). They can also be used to store intermediate results during stigmatization (if you are unsure you can get the astigmatism correction better, copy the contents of the current channel to another and continue stigmatization with the other channel. You can then always go back to first channel if it gets worse).

The active channel is outlined by a frame around it and by the enabled nature of its spin buttons (the arrows are black; those of the inactive channels are gray).

Spin control

Use the buttons of the spin control to change the stigmator setting (an alternative to using the Multifunction knobs).

Flap-out

The flap-out button leads to the Stigmator flap-out with the Stigmator Popup control panel.

Special function: Click with the right-hand mouse button on one of the channels to get a popup-menu.

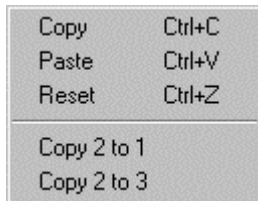

Popup menu functions

Copy

Copies the contents of the channel in which the mouse was clicked to the clipboard.

Paste

Pastes the contents of the clipboard into the channel where the mouse was clicked. This menu item remains grayed (disabled) until a copy action has been done.

Reset

Resets the stigmator channel to zero.

Copy ... to ...

Copies the content of the channel listed first to the channel listed second. The copy action is always from the channel where the right-hand mouse click was done to one of the other channels.

4.74 Stigmator Popup

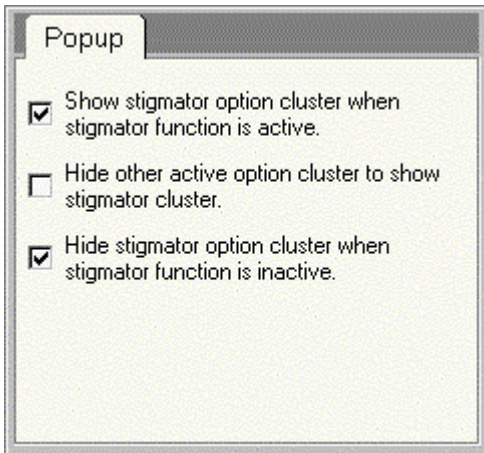

The Stigmator Popup Control Panel.

The Stigmator Popup Control Panel contains a number of options related to the behavior of the Stigmator control panel.

Show .. when .. active

When checked, this option automatically makes the Stigmator control panel pop up at the standard panel popup position (bottom right - unless it is already visible) when stigmator selection is on (through pressing of the Stigmator button on the left-hand Control Pad).

Hide other ..

This option, when checked, makes the Stigmator control panel replace any other control panel currently popped up.

Hide stigmator ...

When checked, this option makes the Stigmator control panel disappear again when the stigmator selection is switched off (by pressing the Stigmator button on the left-hand Control Pad).

4.75 System status

System Status					
Lens					
Spot size	21.58 %				
Intensity	34.22 %				
Minicondenser	94.10 %				
Objective	6.00 %				
Diffraction	18.01 %				
Intermediate	0.00 %				
Projector 1	71.81 %				
Projector 2	64.00 %				
<hr/>					
Gun deflector	X	Y	Perp X	Perp Y	All
Gun tilt	0.0801	-0.0204			U-X -0.1177
Gun shift	0.0200	-0.0540			U-Y 0.0745
Spot-dep. shift	0.0176	-0.0001			L-X -0.0011
Gun tilt pp	5.4830	5.4510	0.0000	0.0000	L-Y -0.0449
Gun shift pp	4.0000	4.0000			
Beam deflector	X	Y	Perp X	Perp Y	All
DF tilt	0.0000	0.0000			U-X 0.0090
User shift	-0.0100	0.0130			U-Y -0.0012
Rot Center	0.0010	-0.0118			L-X -0.0012
Align shift	0.0000	0.0000			L-Y -0.0061
Beam tilt pp	4.2600	4.2600	-0.0010	-0.0012	
Beam shift pp	4.8000	4.8000			
Image deflector	X	Y	Perp X	Perp Y	All
Image-Beam shift	0.0000	0.0000			
User diff. shift	0.0000	0.0000			U-X -0.1243
User image shift	0.0000	0.0000			U-Y -0.0014
Align diff. shift	-0.0020	0.0090			L-X 0.1494
Align image shift	0.1200	-0.0080			L-Y -0.0061
Diff. shift pp	4.6890	4.6930	0.0010	0.0020	
Image shift pp	3.8420	3.8500			
Magn. corr.	0.0300	-0.0010			
Det. alignment	0.0000	0.0000			
X-over corr.	0.0000	0.0000			

The System Status Control Panel.

The System Status Control Panel provides an overview of all (software) values of lenses and deflection coils.

Lens values

The lens values display the currently active lens settings as a percentage of the lens maximum.

Deflection coils

The deflection coils values are shown in non-physical units. These values always lie between -1 and +1, except for the pivot points that lie in the range 2-6.

X-Y values

The X-Y values are the values on the X and Y coils, respectively, for the entries listed on the left.

Perpendicular values

The perpendicular values display the perpendicular corrections applied to the coils. Only one set of perpendicular values exists for a particular deflection coil (thus the shift and tilt components use the same value).

All values

The settings on the deflection coils are first added together. These are then converted by the pivot points into settings applied to upper and lower coils.

Gun coils

The settings on the gun deflection coils consist of the gun tilt, the gun shift and the spot-size dependent gun shift.

Beam coils

The settings on the beam deflection coils consist of four factors, two user factors (user beam shift as set with the track ball, and dark field tilt) and two alignment factors, the align beam shift and the rotation center. Not listed is the contribution from the image shift - beam shift.

Image coils

The settings on the image deflection coils consist of four main factors, two user factors (user image shift and user diffraction shift) and two alignment factors, the align image shift and align diffraction shift. Additionally there are the magnification correction (used for the alignment of the magnifications within a range), the detector alignment (used for the shift to off-axis detectors) and the cross-over correction (used in EFTEM). Not listed is the contribution from the image shift - beam shift.

4.76 Vacuum (User)

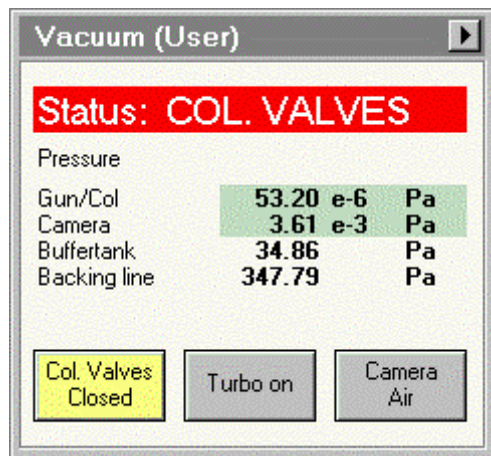

The Vacuum Control Panel.

The Vacuum Control Panel gives an overview of the vacuum status of the microscope and provides access to a few, often-used vacuum-control functions. A more detailed vacuum overview is also available.

Note 1: On systems equipped with the Turbo-Molecular Pump (TMP), to stop the TMP running (usually after inserting a specimen holder) either use the Turbo on button or simply open the Column Valves (if the Turbo Auto Off function on the Vacuum Cryo Control Panel is active).

Note on the Turbo-molecular pump (TMP): When the TMP is switched off, it is forced to run down completely, otherwise there may be situations where it does not start up properly. The run-down of the TMP takes about 7 minutes. While it is running down it cannot be switched on.

Note 2: Vacuum terminology tends to be confusing. People talk about high or ultra-high vacuum when they mean very low pressures. Where it could be confusing, vacuum status will therefore be referred to as 'good' or 'poor'.

Status

The status line of the Vacuum Control panel displays the status of the vacuum in words. Examples of status values are ready, off, stand-by, and start up. A green status display is used for ready, red status displays for not ready. In the example above, the display indicates that the Column Valves are closed.

Pressure read-out

The essential pressures of the microscope are read out, either by pressure gauges like Pirani's or Pennings or by converting the currents going through Ion Getter Pumps to pressures. The important pressures are listed in the Vacuum Control Panel. The pressure units are as set in the Vacuum Settings control panel (or defined by the supervisor for users). Possible units are Pascal, Torr and Log unit. For clarity Pascal and Torr units always go in steps of thousands for the exponent (10⁻³, 10⁻⁶, etc). Log units are defined in such a way that a realistic range of pressures (for that vacuum element) goes from 0 to 100. The advantage of the log units (which are similar to the units previously used on CM microscopes) is simplicity and high sensitivity for the good vacuum values (where it matters) and low sensitivity for poor vacuum values.

Column Valves Closed

The Column Valves Closed button closes and opens the two valves in the column separating the column from the projection chamber (V4) and the column from the gun (V7). These two valves are always opened and closed together. The high tension and filament can remain on when opening and closing these valves. The functionality of the button is chosen such that it highlights (yellow) when the column valves are closed (as a warning that the beam will not be visible). The same is indicated, when possible, by the status display.

It is good practice to keep these valves closed whenever the microscope is not actively used, to keep the column vacuum at its optimum condition and prevent air from entering the gun area during specimen exchange.

Turbo on

Present only on systems equipped with the Turbo-Molecular Pump. In cases where the pre-pump airlock action is not necessary (all airlock actions without cryo holders), it may still be advantageous to switch the TMP on (or off). An example is the removal of the specimen holder in order to exchange the specimen. Since the TMP takes some time to reach Ready status, it can be switched on before removing the specimen holder, so it is ready immediately after the specimen has been exchanged. The switch on and off of the TMP can be done through the Turbo on button.

Note: The Turbo button is orange when the TMP is on but not yet at operational speed. When the TMP is on and at speed, the button is yellow.

Camera Air

The Camera Air button starts the vacuum cycle that vents the camera chamber and, when the camera is vented, starts the cycle that pumps the camera chamber again. Camera Air must be confirmed. For this purpose, the button disappears and is replaced by two buttons, one with a 'V' sign for OK, the other with and 'X' sign for Cancel. The cursor is placed between the two buttons so that it is not possible to press one of them by accidentally pressing the Camera Air button twice. On some microscopes the Camera Air button may be absent. In that case the system Supervisor has chosen to remove the button (typically when no plate camera is used on the system so there is no reason for users to vent the camera).

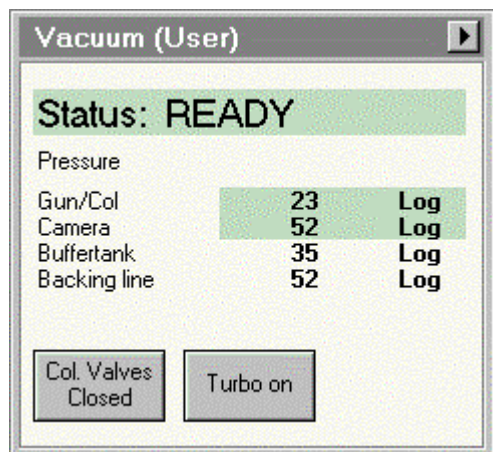

The Vacuum Control Panel with Log units displayed and the Camera Air button absent.

Vacuum Flap-out

Pressing the arrow button displays the flap-out containing the Vacuum Cryo control panel.

4.77 Vacuum Cryo (User)

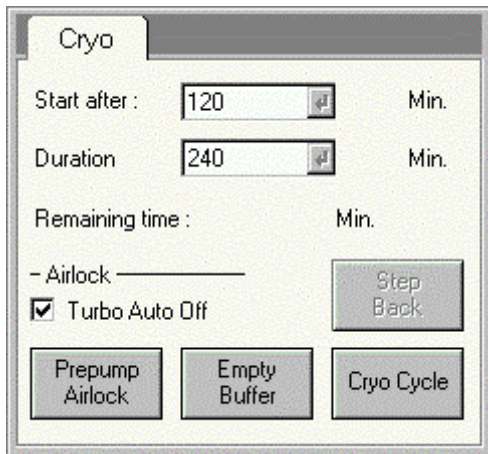

The Vacuum Cryo Control Panel.

The Vacuum Cryo Control Panel contains special cryo functions for prepumping the airlock (to allow rapid insertion of a cryo-transfer holder), switching the Turbo-molecular pump (TMP) on or off, and for the cryo cycle (for removal of water vapor coming off the cold trap or cryo blades when the liquid-nitrogen cooling is removed).

Step Back

There may be occasions where a certain action is undertaken and the vacuum system is unable to reach the final state required (e.g. pumping on the Camera but due to a leaking O-ring the vacuum ready status cannot be reached). In that case you can switch back to the previous vacuum state by pressing the Step Back button, which becomes enabled in cases where a step back is possible.

Turbo Auto Off

The switch off of the Turbo-Molecular Pump can be under automatic control (the microscope will switch the Turbo off when the Column Valve are opened) or manual control. Manual control may be preferable in cases where rapid specimen exchange is required (and the vibrations from the Turbo pump are not important). In the latter case the operator must switch the Turbo off via the Turbo on button. The Turbo Auto Off check box defines whether automatic control (check box checked) or manual control is used.

Prepump Airlock

Note on the Turbo-molecular pump (TMP): When the TMP is switched off, it is forced to run down completely, otherwise there may be situations where it does not start up properly. The run-down of the TMP takes about 7 minutes. While it is running down it cannot be switched on.

Note: the prepump airlock button is disabled when there is a specimen holder inside the CompuStage. First remove the holder and then switch on the prepumping of the airlock.

During insertion of a cryo-transfer holder into the microscope, the greatest danger to the frozen specimen comes from water vapor icing up on the specimen. In order to reduce the time that the holder is in air, the microscope is equipped with a prepump airlock function. When this function is used, the microscope will go through its normal procedure of airlock insertion without the actual pumping of the airlock itself:

- Pump out the backing line
- Check the vacuum level in the buffer tank (behind the oil-diffusion pump) and empty the buffer tank if necessary.

While this is taking place, the red light of the CompuStage will remain on (and the cryo-transfer holder should be kept inside the cryo-transfer workstation). Once the red CompuStage light goes off, the pre-vacuum pump will keep running, to be ready for immediate action when the insertion of the cryo-transfer holder is detected. The airlock will then be pumped (for the user-selected time) after which the holder can be inserted into the microscope.

The **optimum cryo-transfer holder insertion procedure** is as follows:

- Keep the cryo-transfer holder in the transfer workstation.
- Go to the Stage² Control Control Panel, enter a value of -60 for the Set Alpha and press the button. The stage will now be tilted to -60 degrees. This pre-tilt is useful for two reasons:
 1. It is now possible to insert the specimen holder without spilling all the liquid nitrogen out of the dewar.
 2. By making the stage go back to 0 degrees later while the holder is kept in the same orientation (by the operator), the CompuStage will itself take care of opening the airlock.
- Go to the Vacuum Cryo Control Panel and press the Prepump Airlock button.
- The red CompuStage light will now be on.
- Wait until the red CompuStage light is switched off.
- Remove the specimen holder from the transfer workstation and insert it into the CompuStage.
- The red CompuStage will again go on and the airlock pumping will start immediately.
- Wait till the red CompuStage light goes off.
- Hold the specimen holder firmly so it cannot rotate and press the Set Alpha button again.
- The CompuStage will now tilt back to 0 degrees. Because the holder will not tilt with it, the holder effectively opens the airlock in this way (the same as the operator turning the holder so it will open the airlock).
- Insert the specimen holder further into the microscope.
- On TMP systems: If necessary (e.g. when the cryo holders shields will not be opened for a while to allow the vacuum to recover fully from the holder insertion), switch the TMP off via the Turbo on button (otherwise it will be switched off automatically when the column valves are opened if the Turbo Auto Off function is active).

Empty Buffer

The Empty Buffer button starts the cycle that empties the buffer tank. This may be useful in cases where it is necessary that the buffer cycle doesn't interrupt operation for a period of time (e.g. when a series of exposures is to be made).

Cryo cycle

The Cryo cycle is a special vacuum procedure for removing the water vapor from the microscope column that is released when the cold trap or cryo blades are being warmed up at the end of a cryo-microscopy session. The IGP 1 that pumps the microscope column is not a very effective pump for removal of water vapor (and ages more rapidly when it is forced to pump a lot of water vapor repeatedly) and therefore the TMP or ODP is used to pump away the water vapor while IGP 1 is temporarily switched off. After a set time has elapsed, the IGP 1 is automatically switched on again so the microscope is ready for operation the next morning.

The cryo cycle is based on two settings, a delay time before the function switches IGP 1 off (Start after) and a running time after which the microscope will (attempt to) switch IGP 1 on again (Duration). To determine what these settings should be, observe the behavior of the microscope vacuum system after a normal day of cryo-microscopy operation. Stop the microscope session. If you normally remove the liquid-nitrogen dewar of the cold trap, do so now. Record the time until the pressure in the column begins to rise significantly (due to water vapor coming off the cold trap or cryo blades). Take 3/4 of this time as the Start after value. Estimate how it will normally take to evaporate all the water from the cold trap or cryo blades (with the liquid-nitrogen dewar removed this is typically less than 1/2 hour, with it there it may take longer). Select that time (with some margin for variation) as the Duration time.

Note: To ensure that the vacuum doesn't deteriorate in case the Start after time is too long, the vacuum system will terminate the Start after period and switch to the real part of the cryo cycle (Duration) when it finds that IGP 1 is running up significantly. The cryo cycle then continues normally.

During the cryo cycle a number of vacuum controls (column valves, prepump airlock, etc.) are disabled. It is also not possible to change the cryo cycle settings while the cycle is running. The cryo cycle can be switched off by pressing the (now yellow) Cryo Cycle button.

4.78 Vacuum (Expert)

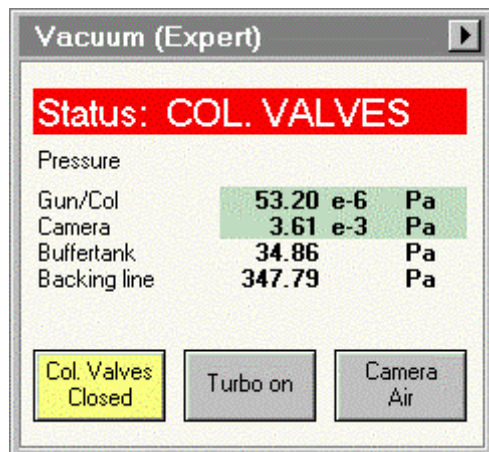

The Vacuum Control Panel.

The Vacuum Control Panel gives an overview of the vacuum status of the microscope and provides access to a few, often-used vacuum-control functions. A more detailed vacuum overview is also available.

Note 1: On systems equipped with the Turbo-Molecular Pump (TMP), to stop the TMP running (usually after inserting a specimen holder) either use the Turbo on button or simply open the Column Valves (if the Turbo Auto Off function on the Vacuum Cryo Control Panel is active).

Note on the Turbo-molecular pump (TMP): When the TMP is switched off, it is forced to run down completely, otherwise there may be situations where it does not start up properly. The run-down of the TMP takes about 7 minutes. While it is running down it cannot be switched on.

Note 2: Vacuum terminology tends to be confusing. People talk about high or ultra-high vacuum when they mean very low pressures. Where it could be confusing, vacuum status will therefore be referred to as 'good' or 'poor'.

Status

The status line of the Vacuum Control panel displays the status of the vacuum in words. Examples of status values are ready, off, stand-by, and start up. A green status display is used for ready, red status displays for not ready. In the example above, the display indicates that the Column Valves are closed.

Pressure read-out

The essential pressures of the microscope are read out, either by pressure gauges like Pirani's or Pennings or by converting the currents going through Ion Getter Pumps to pressures. The important pressures are listed in the Vacuum Control Panel. The pressure units are as set in the Vacuum Settings control panel (or defined by the supervisor for users). Possible units are Pascal, Torr and Log unit. For clarity Pascal and Torr units always go in steps of thousands for the exponent (10⁻³, 10⁻⁶, etc). Log units are defined in such a way that a realistic range of pressures (for that vacuum element) goes from 0 to 100. The advantage of the log units (which are similar to the units previously used on CM microscopes) is simplicity and high sensitivity for the good vacuum values (where it matters) and low sensitivity for poor vacuum values.

Column Valves Closed

The Column Valves Closed button closes and opens the two valves in the column separating the column from the projection chamber (V4) and the column from the gun (V7). These two valves are always opened and closed together. The high tension and filament can remain on when opening and closing these valves. The functionality of the button is chosen such that it highlights (yellow) when the column valves are closed (as a warning that the beam will not be visible). The same is indicated, when possible, by the status display.

It is good practice to keep these valves closed whenever the microscope is not actively used, to keep the column vacuum at its optimum condition and prevent air from entering the gun area during specimen exchange.

Turbo on

Present only on systems equipped with the Turbo-Molecular Pump. In cases where the pre-pump airlock action is not necessary (all airlock actions without cryo holders), it may still be advantageous to switch the TMP on (or off). An example is the removal of the specimen holder in order to exchange the specimen. Since the TMP takes some time to reach Ready status, it can be switched on before removing the specimen holder, so it is ready immediately after the specimen has been exchanged. The switch on and off of the TMP can be done through the Turbo on button.

Note: The Turbo button is orange when the TMP is on but not yet at operational speed. When the TMP is on and at speed, the button is yellow.

Camera Air

The Camera Air button starts the vacuum cycle that vents the camera chamber and, when the camera is vented, starts the cycle that pumps the camera chamber again. Camera Air must be confirmed. For this purpose, the button disappears and is replaced by two buttons, one with a 'V' sign for OK, the other with and 'X' sign for Cancel. The cursor is placed between the two buttons so that it is not possible to press one of them by accidentally pressing the Camera Air button twice. On some microscopes the Camera Air button may be absent. In that case the system Supervisor has chosen to remove the button (typically when no plate camera is used on the system so there is no reason for users to vent the camera).

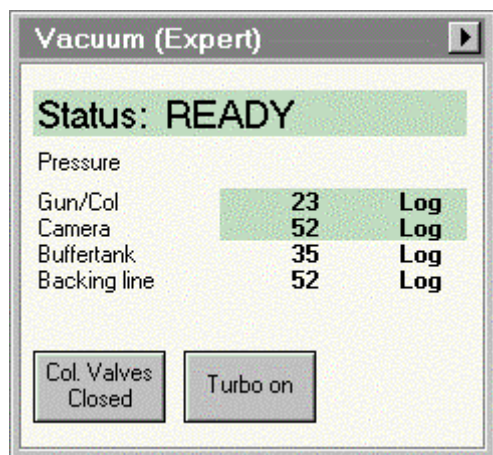

The Vacuum Control Panel with Log units displayed and the Camera Air button absent.

Vacuum Flap-out

Pressing the arrow button displays the flap-out containing the Vacuum Cryo and Vacuum Settings control panels.

4.79 Vacuum Cryo (Expert)

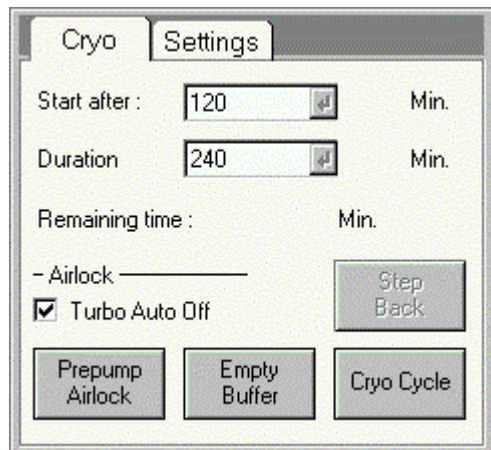

The Vacuum Cryo Control Panel.

The Vacuum Cryo Control Panel contains special cryo functions for prepumping the airlock (to allow rapid insertion of a cryo-transfer holder), switching the Turbo-molecular pump (TMP) on or off, and for the cryo cycle (for removal of water vapor coming off the cold trap or cryo blades when the liquid-nitrogen cooling is removed).

Step Back

There may be occasions where a certain action is undertaken and the vacuum system is unable to reach the final state required (e.g. pumping on the Camera but due to a leaking O-ring the vacuum ready status cannot be reached). In that case you can switch back to the previous vacuum state by pressing the Step Back button, which becomes enabled in cases where a step back is possible.

Turbo Auto Off

The switch off of the Turbo-Molecular Pump can be under automatic control (the microscope will switch the Turbo off when the Column Valve are opened) or manual control. Manual control may be preferable in cases where rapid specimen exchange is required (and the vibrations from the Turbo pump are not important). In the latter case the operator must switch the Turbo off via the Turbo on button. The Turbo Auto Off check box defines whether automatic control (check box checked) or manual control is used.

Prepump Airlock

Note on the Turbo-molecular pump (TMP): When the TMP is switched off, it is forced to run down completely, otherwise there may be situations where it does not start up properly. The run-down of the TMP takes about 7 minutes. While it is running down it cannot be switched on.

Note: the prepump airlock button is disabled when there is a specimen holder inside the CompuStage. First remove the holder and then switch on the prepumping of the airlock.

During insertion of a cryo-transfer holder into the microscope, the greatest danger to the frozen specimen comes from water vapor icing up on the specimen. In order to reduce the time that the holder is in air, the microscope is equipped with a prepump airlock function. When this function is used, the microscope will go through its normal procedure of airlock insertion without the actual pumping of the airlock itself:

- Pump out the backing line
- Check the vacuum level in the buffer tank (behind the oil-diffusion pump) and empty the buffer tank if necessary.

While this is taking place, the red light of the CompuStage will remain on (and the cryo-transfer holder should be kept inside the cryo-transfer workstation). Once the red CompuStage light goes off, the pre-vacuum pump will keep running, to be ready for immediate action when the insertion of the cryo-transfer holder is detected. The airlock will then be pumped (for the user-selected time) after which the holder can be inserted into the microscope.

The **optimum cryo-transfer holder insertion procedure** is as follows:

- Keep the cryo-transfer holder in the transfer workstation.
- Go to the Stage² Control Control Panel, enter a value of -60 for the Set Alpha and press the button. The stage will now be tilted to -60 degrees. This pre-tilt is useful for two reasons:
 3. It is now possible to insert the specimen holder without spilling all the liquid nitrogen out of the dewar.
 4. By making the stage go back to 0 degrees later while the holder is kept in the same orientation (by the operator), the CompuStage will itself take care of opening the airlock.
- Go to the Vacuum Cryo Control Panel and press the Prepump Airlock button.
- The red CompuStage light will now be on.
- Wait until the red CompuStage light is switched off.
- Remove the specimen holder from the transfer workstation and insert it into the CompuStage.
- The red CompuStage will again go on and the airlock pumping will start immediately.
- Wait till the red CompuStage light goes off.
- Hold the specimen holder firmly so it cannot rotate and press the Set Alpha button again.
- The CompuStage will now tilt back to 0 degrees. Because the holder will not tilt with it, the holder effectively opens the airlock in this way (the same as the operator turning the holder so it will open the airlock).
- Insert the specimen holder further into the microscope.
- On TMP systems: If necessary (e.g. when the cryo holders shields will not be opened for a while to allow the vacuum to recover fully from the holder insertion), switch the TMP off via the Turbo on button (otherwise it will be switched off automatically when the column valves are opened if the Turbo Auto Off function is active).

Empty Buffer

The Empty Buffer button starts the cycle that empties the buffer tank. This may be useful in cases where it is necessary that the buffer cycle doesn't interrupt operation for a period of time (e.g. when a series of exposures is to be made).

Cryo cycle

The Cryo cycle is a special vacuum procedure for removing the water vapor from the microscope column that is released when the cold trap or cryo blades are being warmed up at the end of a cryo-microscopy session. The IGP 1 that pumps the microscope column is not a very effective pump for removal of water vapor (and ages more rapidly when it is forced to pump a lot of water vapor repeatedly) and therefore the TMP or ODP is used to pump away the water vapor while IGP 1 is temporarily switched off. After a set time has elapsed, the IGP 1 is automatically switched on again so the microscope is ready for operation the next morning.

The cryo cycle is based on two settings, a delay time before the function switches IGP 1 off (Start after) and a running time after which the microscope will (attempt to) switch IGP 1 on again (Duration). To determine what these settings should be, observe the behavior of the microscope vacuum system after a normal day of cryo-microscopy operation. Stop the microscope session. If you normally remove the liquid-nitrogen dewar of the cold trap, do so now. Record the time until the pressure in the column begins to rise significantly (due to water vapor coming off the cold trap or cryo blades). Take 3/4 of this time as the Start after value. Estimate how it will normally take to evaporate all the water from the cold trap or cryo blades (with the liquid-nitrogen dewar removed this is typically less than 1/2 hour, with it there it may take longer). Select that time (with some margin for variation) as the Duration time.

Note: To ensure that the vacuum doesn't deteriorate in case the Start after time is too long, the vacuum system will terminate the Start after period and switch to the real part of the cryo cycle (Duration) when it finds that IGP 1 is running up significantly. The cryo cycle then continues normally.

During the cryo cycle a number of vacuum controls (column valves, prepump airlock, etc.) are disabled. It is also not possible to change the cryo cycle settings while the cycle is running. The cryo cycle can be switched off by pressing the (now yellow) Cryo Cycle button.

4.80 Vacuum Settings (Expert)

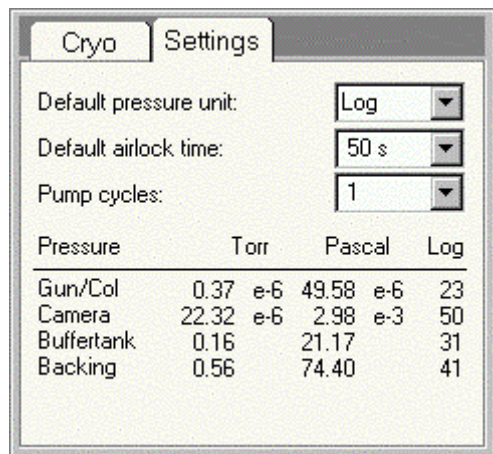

The Vacuum Settings Control Panel.

The Vacuum Settings Control Panel allows experts and supervisor access to various settings concerning the vacuum system. Settings determined by the supervisor automatically apply to users.

Default Pressure Unit

Vacuum pressures can be listed in three types of units, Pascal (Pa), Torr and Log unit. For clarity Pascal and Torr units always go in steps of thousands for the exponent (10⁻³, 10⁻⁶, etc). Log units are defined in such a way that a realistic range of pressures (for that vacuum element) goes from 0 to 100. The advantage of the log units (which are similar to the units previously used on CM microscopes) is simplicity and high sensitivity for the good vacuum values (where it matters) and low sensitivity for poor vacuum values.

Default Airlock Time

Airlock pumping times can be set by the user. The minimum airlock pumping time advised is 50 seconds for TMP systems and 30 seconds for systems without TMP.

Flush cycles

Present only on systems equipped with the Turbo-Molecular Pump. The TMP can be set to pump on the airlock in a single cycle or in more cycles, interspersed by flushing with nitrogen. If a single cycle is set, no flushing takes place, otherwise the systems pumps, flushes, pumps, ... (depending on the number of cycles set).

Pressures

A list of all vacuum pressures in all three types of units simultaneously.

4.81 Vacuum (Supervisor)

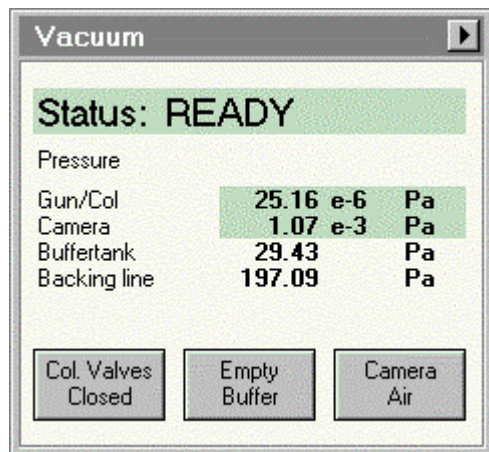

The Vacuum Control Panel.

The Vacuum Control Panel gives an overview of the vacuum status of the microscope and provides access to a few, often-used vacuum-control functions. A more detailed vacuum overview is also available.

Note 1: On systems equipped with the Turbo-Molecular Pump (TMP), to stop the TMP running (usually after inserting a specimen holder) either use the Turbo on button or simply open the Column Valves (if the Turbo Auto Off function on the Vacuum Cryo Control Panel is active).

Note on the Turbo-molecular pump (TMP): When the TMP is switched off, it is forced to run down completely, otherwise there may be situations where it does not start up properly. The run-down of the TMP takes about 7 minutes. While it is running down it cannot be switched on.

Note 2: Vacuum terminology tends to be confusing. People talk about high or ultra-high vacuum when they mean very low pressures. Where it could be confusing, vacuum status will therefore be referred to as 'good' or 'poor'.

Status

The status line of the Vacuum Control panel displays the status of the vacuum in words. Examples of status values are ready, off, stand-by, and start up. A green status display is used for ready, red status displays for not ready. In the example above, the display indicates that the Column Valves are closed.

Pressure read-out

The essential pressures of the microscope are read out, either by pressure gauges like Pirani's or Pennings or by converting the currents going through Ion Getter Pumps to pressures. The important pressures are listed in the Vacuum Control Panel. The pressure units are as set in the Vacuum Settings control panel (or defined by the supervisor for users). Possible units are Pascal, Torr and Log unit. For clarity Pascal and Torr units always go in steps of thousands for the exponent (10⁻³, 10⁻⁶, etc). Log units are defined in such a way that a realistic range of pressures (for that vacuum element) goes from 0 to 100. The advantage of the log units (which are similar to the units previously used on CM microscopes) is simplicity and high sensitivity for the good vacuum values (where it matters) and low sensitivity for poor vacuum values.

Column Valves Closed

The Column Valves Closed button closes and opens the two valves in the column separating the column from the projection chamber (V4) and the column from the gun (V7). These two valves are always opened and closed together. The high tension and filament can remain on when opening and closing these valves. The functionality of the button is chosen such that it highlights (yellow) when the column valves are closed (as a warning that the beam will not be visible). The same is indicated, when possible, by the status display.

It is good practice to keep these valves closed whenever the microscope is not actively used, to keep the column vacuum at its optimum condition and prevent air from entering the gun area during specimen exchange.

Turbo on

Present only on systems equipped with the Turbo-Molecular Pump. In cases where the pre-pump airlock action is not necessary (all airlock actions without cryo holders), it may still be advantageous to switch the TMP on (or off). An example is the removal of the specimen holder in order to exchange the specimen. Since the TMP takes some time to reach Ready status, it can be switched on before removing the specimen holder, so it is ready immediately after the specimen has been exchanged. The switch on and off of the TMP can be done through the Turbo on button.

Note: The Turbo button is orange when the TMP is on but not yet at operational speed. When the TMP is on and at speed, the button is yellow.

Camera Air

The Camera Air button starts the vacuum cycle that vents the camera chamber and, when the camera is vented, starts the cycle that pumps the camera chamber again. Camera Air must be confirmed. For this purpose, the button disappears and is replaced by two buttons, one with a 'V' sign for OK, the other with an 'X' sign for Cancel. The cursor is placed between the two buttons so that it is not possible to press one of them by accidentally pressing the Camera Air button twice. On some microscopes the Camera Air button may be absent. In that case the system Supervisor has chosen to remove the button (typically when no plate camera is used on the system so there is no reason for users to vent the camera).

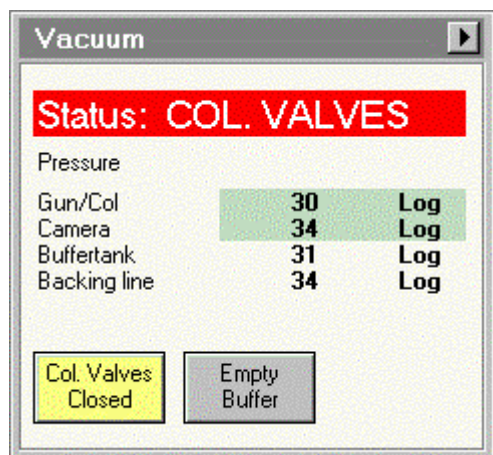

The Vacuum Control Panel with Log units displayed and the Camera Air button absent.

Vacuum Flap-out

Pressing the arrow button displays the flap-out containing the Vacuum Cryo, Vacuum Settings and Vacuum Control control panels.

4.82 Vacuum Control (Supervisor)

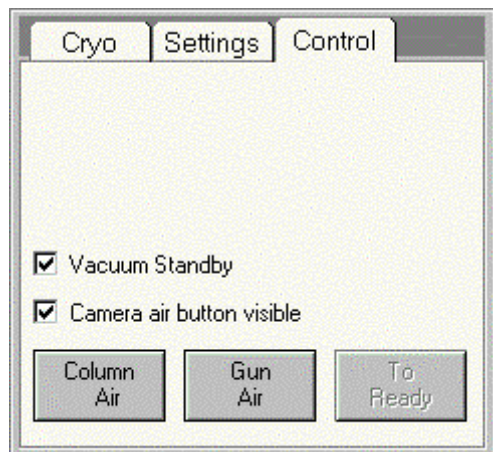

The Vacuum Control Control Panel.

The Vacuum Control Control Panel allows the supervisor to control certain elements of the microscope's vacuum system.

Vacuum Standby

When the microscope (and vacuum system) is switched off, generally it takes about 1/2 to 1 hour to restart (warming up of the Oil-Diffusion Pump up to pumping of the column and gun with IGP 1 and IGP 2). This time can be shortened appreciably by leaving IGP 1 and IGP 2 running, which is the function of the Standby vacuum mode (the default setting - the checkbox is checked). Under some circumstances, it may be necessary to switch IGP 1 and IGP 2 off as well. In that case, the Standby mode must be switched off (uncheck the Standby checkbox) and then switch the vacuum system off. The Vacuum Standby function is available only to the Supervisor.

Camera Air button visible

The checkbox Camera Air button determines whether the Camera Air button on the Vacuum Control Panel is visible or not. This option can be set only by the Supervisor and applies to all users (Experts and Users) of the microscope. When the plate camera of the microscope is never used, the Camera Air button can be made invisible, since there is then no reason for users to vent the camera.

Column Air

The Column Air buttons starts (or stops) venting the Column. The Column Air functionality is available only to the Supervisor. Column Air must be confirmed. For this purpose, the button disappears and is replaced by two buttons, one with a 'V' sign for OK, the other with and 'X' sign for Cancel. The cursor is placed between the two buttons so that it is not possible to press one of them by accidentally pressing the Column Air button twice.

Gun Air

The Gun Air buttons starts (or stops) venting the Gun. The Gun Air functionality is available only to the Supervisor. Gun Air must be confirmed. For this purpose, the button disappears and is replaced by two buttons, one with a 'V' sign for OK, the other with and 'X' sign for Cancel. The cursor is placed between the two buttons so that it is not possible to press one of them by accidentally pressing the Gun Air button twice.

To Ready

In cases where the vacuum system has come to state where it (currently) does not know how to resolve the situation, the To Ready button may become active. By pressing the button the Supervisor can attempt to get the vacuum system back to the Ready state.

4.83 Vacuum Cryo (Supervisor)

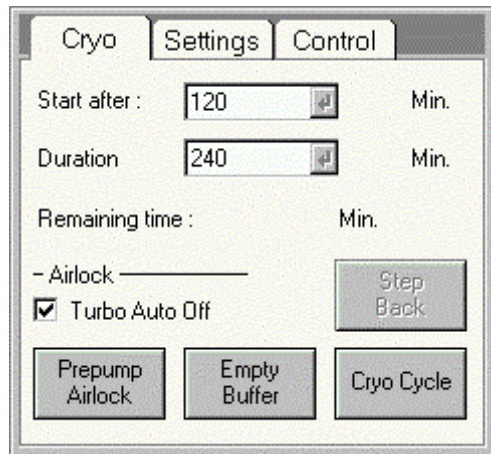

The Vacuum Cryo Control Panel.

The Vacuum Cryo Control panel contains special cryo functions for prepumping the airlock (to allow rapid insertion of a cryo-transfer holder), switching the Turbo-molecular pump (TMP) on or off, and for the cryo cycle (for removal of water vapor coming off the cold trap or cryo blades when the liquid-nitrogen cooling is removed).

Step Back

There may be occasions where a certain action is undertaken and the vacuum system is unable to reach the final state required (e.g. pumping on the Camera but due to a leaking O-ring the vacuum ready status cannot be reached). In that case you can switch back to the previous vacuum state by pressing the Step Back button, which becomes enabled in cases where a step back is possible.

Turbo Auto Off

The switch off of the Turbo-Molecular Pump can be under automatic control (the microscope will switch the Turbo off when the Column Valve are opened) or manual control. Manual control may be preferable in cases where rapid specimen exchange is required (and the vibrations from the Turbo pump are not important). In the latter case the operator must switch the Turbo off via the Turbo on button. The Turbo Auto Off check box defines whether automatic control (check box checked) or manual control is used.

Prepump Airlock

Note on the Turbo-molecular pump (TMP): When the TMP is switched off, it is forced to run down completely, otherwise there may be situations where it does not start up properly. The run-down of the TMP takes about 7 minutes. While it is running down it cannot be switched on.

Note: the prepump airlock button is disabled when there is a specimen holder inside the CompuStage. First remove the holder and then switch on the prepumping of the airlock.

During insertion of a cryo-transfer holder into the microscope, the greatest danger to the frozen specimen comes from water vapor icing up on the specimen. In order to reduce the time that the holder is in air, the microscope is equipped with a prepump airlock function. When this function is used, the microscope will go through its normal procedure of airlock insertion without the actual pumping of the airlock itself:

- Pump out the backing line
- Check the vacuum level in the buffer tank (behind the oil-diffusion pump) and empty the buffer tank if necessary.

While this is taking place, the red light of the CompuStage will remain on (and the cryo-transfer holder should be kept inside the cryo-transfer workstation). Once the red CompuStage light goes off, the pre-vacuum pump will keep running, to be ready for immediate action when the insertion of the cryo-transfer holder is detected. The airlock will then be pumped (for the user-selected time) after which the holder can be inserted into the microscope.

The **optimum cryo-transfer holder insertion procedure** is as follows:

- Keep the cryo-transfer holder in the transfer workstation.
- Go to the Stage² Control Control Panel, enter a value of -60 for the Set Alpha and press the button. The stage will now be tilted to -60 degrees. This pre-tilt is useful for two reasons:
 5. It is now possible to insert the specimen holder without spilling all the liquid nitrogen out of the dewar.
 6. By making the stage go back to 0 degrees later while the holder is kept in the same orientation (by the operator), the CompuStage will itself take care of opening the airlock.
- Go to the Vacuum Cryo Control Panel and press the Prepump Airlock button.
- The red CompuStage light will now be on.
- Wait until the red CompuStage light is switched off.
- Remove the specimen holder from the transfer workstation and insert it into the CompuStage.
- The red CompuStage will again go on and the airlock pumping will start immediately.
- Wait till the red CompuStage light goes off.
- Hold the specimen holder firmly so it cannot rotate and press the Set Alpha button again.
- The CompuStage will now tilt back to 0 degrees. Because the holder will not tilt with it, the holder effectively opens the airlock in this way (the same as the operator turning the holder so it will open the airlock).
- Insert the specimen holder further into the microscope.
- On TMP systems: If necessary (e.g. when the cryo holders shields will not be opened for a while to allow the vacuum to recover fully from the holder insertion), switch the TMP off via the Turbo on button (otherwise it will be switched off automatically when the column valves are opened if the Turbo Auto Off function is active).

Empty Buffer

The Empty Buffer button starts the cycle that empties the buffer tank. This may be useful in cases where it is necessary that the buffer cycle doesn't interrupt operation for a period of time (e.g. when a series of exposures is to be made).

Cryo cycle

The Cryo cycle is a special vacuum procedure for removing the water vapor from the microscope column that is released when the cold trap or cryo blades are being warmed up at the end of a cryo-microscopy session. The IGP 1 that pumps the microscope column is not a very effective pump for removal of water vapor (and ages more rapidly when it is forced to pump a lot of water vapor repeatedly) and therefore the TMP or ODP is used to pump away the water vapor while IGP 1 is temporarily switched off. After a set time has elapsed, the IGP 1 is automatically switched on again so the microscope is ready for operation the next morning.

The cryo cycle is based on two settings, a delay time before the function switches IGP 1 off (Start after) and a running time after which the microscope will (attempt to) switch IGP 1 on again (Duration). To determine what these settings should be, observe the behavior of the microscope vacuum system after a normal day of cryo-microscopy operation. Stop the microscope session. If you normally remove the liquid-nitrogen dewar of the cold trap, do so now. Record the time until the pressure in the column begins to rise significantly (due to water vapor coming off the cold trap or cryo blades). Take 3/4 of this time as the Start after value. Estimate how it will normally take to evaporate all the water from the cold trap or cryo blades (with the liquid-nitrogen dewar removed this is typically less than 1/2 hour, with it there it may take longer). Select that time (with some margin for variation) as the Duration time.

Note: To ensure that the vacuum doesn't deteriorate in case the Start after time is too long, the vacuum system will terminate the Start after period and switch to the real part of the cryo cycle (Duration) when it finds that IGP 1 is running up significantly. The cryo cycle then continues normally.

During the cryo cycle a number of vacuum controls (column valves, prepump airlock, etc.) are disabled. It is also not possible to change the cryo cycle settings while the cycle is running. The cryo cycle can be switched off by pressing the (now yellow) Cryo Cycle button.

4.84 Vacuum Settings (Supervisor)

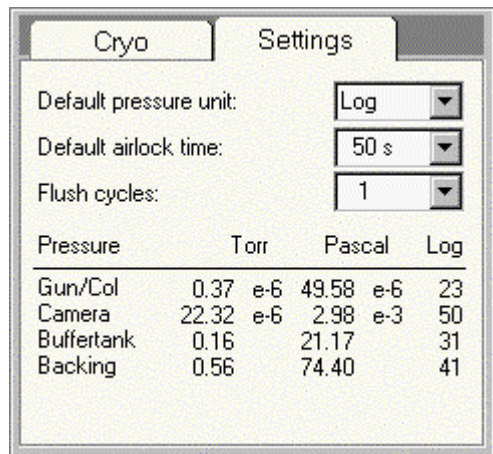

The Vacuum Settings Control Panel.

The Vacuum Settings Control Panel allows experts and supervisor access to various settings concerning the vacuum system. Settings determined by the supervisor automatically apply to users.

Default Pressure Unit

Vacuum pressures can be listed in three types of units, Pascal (Pa), Torr and Log unit. For clarity Pascal and Torr units always go in steps of thousands for the exponent (10⁻³, 10⁻⁶, etc). Log units are defined in such a way that a realistic range of pressures (for that vacuum element) goes from 0 to 100. The advantage of the log units (which are similar to the units previously used on CM microscopes) is simplicity and high sensitivity for the good vacuum values (where it matters) and low sensitivity for poor vacuum values.

Default Airlock Time

Airlock pumping times can be set by the user. The minimum airlock pumping time advised is 50 seconds for TMP systems and 30 seconds for systems without TMP.

Flush cycles

Present only on systems equipped with the Turbo-Molecular Pump. The TMP can be set to pump on the airlock in a single cycles or in more cycles, interspersed by flushing with nitrogen. If a single cycle is set, no flushing takes place, otherwise the systems pumps, flushes, pumps, ... (depending on the number of cycles set).

Pressures

A list of all vacuum pressures in all three types of units simultaneously.

4.85 Vacuum Overview

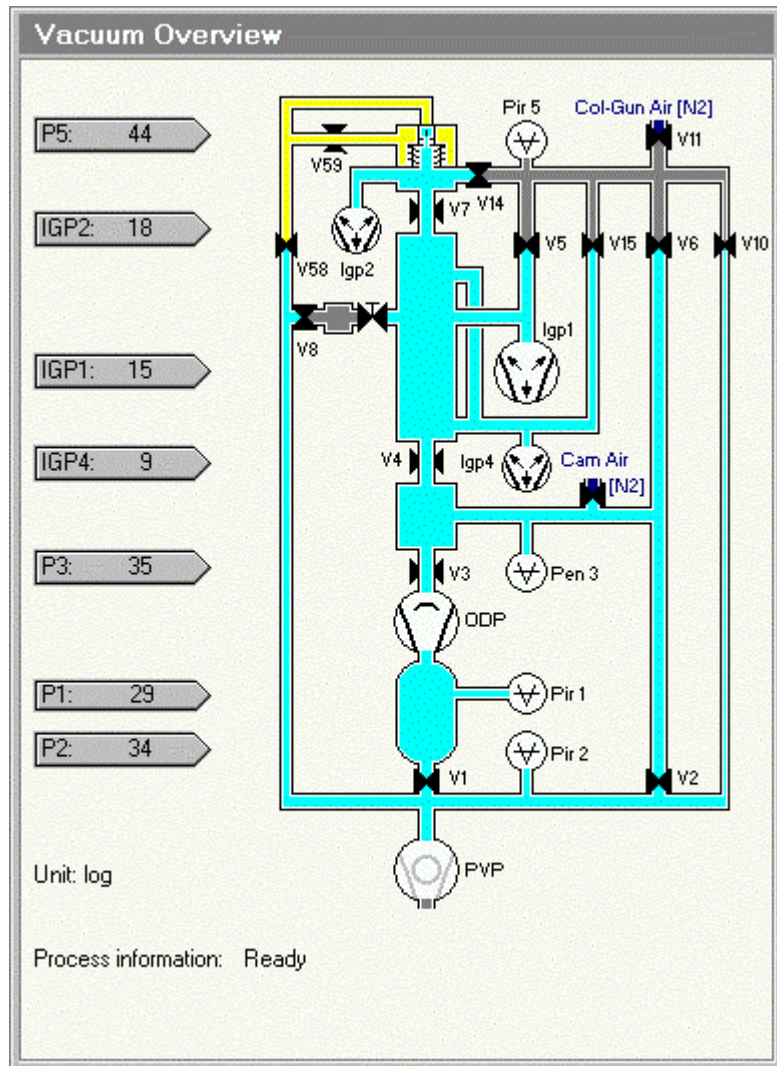

The Vacuum Overview Control Panel.

The Vacuum Overview Control Panel is available only under the control panel selection at the bottom right (its size is too large to fit otherwise). The overview display the current status of the vacuum system.

The overview displays the following elements:

- pumps (indicated by their vacuum-technology symbols)
- pumping lines and volumes
- gauges
- valves
- pressure read outs
- process information
- N2 indicates connections for inlet of nitrogen gas when a certain volume is vented (let up to air).

Pumps

The microscope contains a number of pumps, of different types. The various pumps are indicated by their vacuum technology symbols:



Ion-getter pump (IGP)



Oil-diffusion pump (ODP)



Rotary or pre-vacuum pump (PVP)

Pumps that are active are shown in black on the inside, inactive pumps in gray.

The microscope contains the following pumps:

- IGP1 pumps on the specimen area.
- IGP4 (if present) pumps on the liner tubes at the condenser and selected-area aperture level.
- ODP pumps on the projection chamber.
- PVP pumps on the buffer tank (backing of the ODP) and on the projection chamber before the ODP.

Pumping lines and volumes

Lines and volumes are indicated in colors, with the blue colors indicating active lines and volumes, and a lighter color indicating lower pressure (higher vacuum). Yellow indicates SF6 (in the gun).

Gauges

Gauges are vacuum elements that are used to measure pressures (in addition to pressure measurements derived from the current of the Ion Getter Pumps). Three types of gauges exist, Pirani's, Pennings and combined Pirani-Pennings. The following gauges are present in the vacuum system:

- Pirani 1 - Measures pressure in the buffer tank.
- Pirani 2 - Measures pressure in the backing line (line going from main vacuum system to rotary pump).
- Penning 3 - Measures pressure in projection chamber.
- Pirani 5 - Measures pressure in lines behind column. Used to determine if it is safe to switch on IGP's.

Valves

Valves are indicated by a butterfly-like symbol. In closed valves the 'butterfly wings' touch each other, for open valves there is an opening between the 'wings'. Valves with a 'capital T'-like symbol between the 'wings' indicate a manual valve. Of the valves present in the system, the following have special importance:

V4 and V7 are the column valves, which are under user control (as well as automatic control by the vacuum system).

The unmarked valve to the right of V8 (the airlock valve) is the valve inside the CompuStage goniometer that is opened and closed by the rotation of the specimen holder during insertion or retraction. It is therefore a manual valve (as indicated by the T on the valve).

Pressure read-out

The gray arrows indicate the values of the pressures read-out (units are as selected in the Vacuum Settings control panel). The arrows roughly point to the vacuum gauge or pump used to read out the pressure.

Process information

The process information lists up to four messages about the status of the vacuum system.

4.86 Vacuum Overview (TMP)

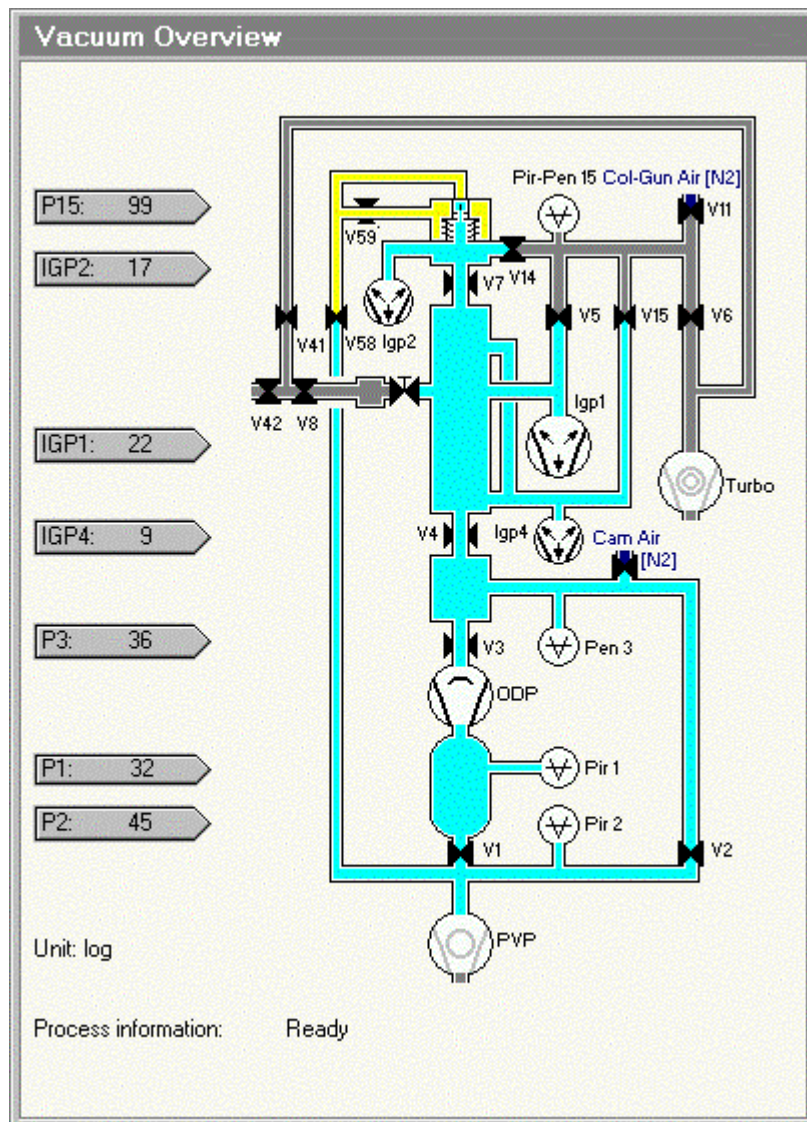

The Vacuum Overview (TMP) Control Panel.

The Vacuum Overview Control Panel is available only under the control panel selection at the bottom right (its size is too large to fit otherwise). The overview display the current status of the vacuum system.

The overview displays the following elements:

- pumps (indicated by their vacuum-technology symbols)
- pumping lines and volumes
- gauges
- valves
- pressure read outs
- process information
- N2 indicates connections for inlet of nitrogen gas when a certain volume is vented (let up to air).

Pumps

The microscope contains a number of pumps, of different types. The various pumps are indicated by their vacuum technology symbols:



Ion-getter pump (IGP)



Turbo-molecular pump



Oil-diffusion pump (ODP)



Rotary or pre-vacuum pump (PVP)

Pumps that are active are shown in black on the inside, inactive pumps in gray.

The microscope contains the following pumps:

- IGP1 pumps on the specimen area.
- IGP4 (if present) pumps on the liner tubes at the condenser and selected-area aperture level.
- Turbo (and its backing diaphragm pump; the latter not shown in this diagram) prepumps the column (and gun) and pumps on the specimen-holder airlock.
- ODP pumps on the projection chamber.
- PVP pumps on the buffer tank (backing of the ODP) and on the projection chamber before the ODP.

For microscopes equipped with a turbo-molecular pump on the airlock: The turbo-molecular pump (which should not remain running under normal microscopy because of the vibrations it causes) takes several minutes (2-3) to reach operational speed. To speed up specimen exchange, it is advised to switch the pump on (use the toolbar button) before extracting the holder. By the time the specimen has been exchanged the turbo-molecular pump will be near or at its operation speed and pumping on the airlock will begin (almost) immediately. Switch the pump off again after the holder has been inserted fully into the microscope.

If the turbo-molecular pump is running on when the specimen holder is inserted into the airlock, the pump will first spin up and only after a few minutes start pumping on the airlock. The pump will be switched off automatically after pumping on the airlock has finished.

Pumping lines and volumes

Lines and volumes are indicated in colors, with the blue colors indicating active lines and volumes, and a lighter color indicating lower pressure (higher vacuum). Yellow indicates SF6 (in the gun).

Gauges

Gauges are vacuum elements that are used to measure pressures (in addition to pressure measurements derived from the current of the Ion Getter Pumps). Three types of gauges exist, Pirani's, Pennings and combined Pirani-Pennings. The following gauges are present in the vacuum system:

- Pirani 1 - Measures pressure in the buffer tank.
- Pirani 2 - Measures pressure in the backing line (line going from main vacuum system to rotary pump).
- Penning 3 - Measures pressure in projection chamber.
- Pirani-Penning 15 - Measures pressure in lines behind column. Used to determine if it is safe to switch on IGPs.

Valves

Valves are indicated by a butterfly-like symbol. In closed valves the 'butterfly wings' touch each other, for open valves there is an opening between the 'wings'. Valves with a 'capital T'-like symbol between the 'wings' indicate a manual valve. Of the valves present in the system, the following have special importance:

V4 and V7 are the column valves, which are under user control (as well as automatic control by the vacuum system).

The unmarked valve to the right of V8 (the airlock valve) is the valve inside the CompuStage goniometer that is opened and closed by the rotation of the specimen holder during insertion or retraction. It is therefore a manual valve (as indicated by the T on the valve).

Pressure read-out

The gray arrows indicate the values of the pressures read-out (units are as selected in the Vacuum Settings control panel). The arrows roughly point to the vacuum gauge or pump used to read out the pressure.

Process information

The process information lists up to four messages about the status of the vacuum system.

4.87 Workspace layout

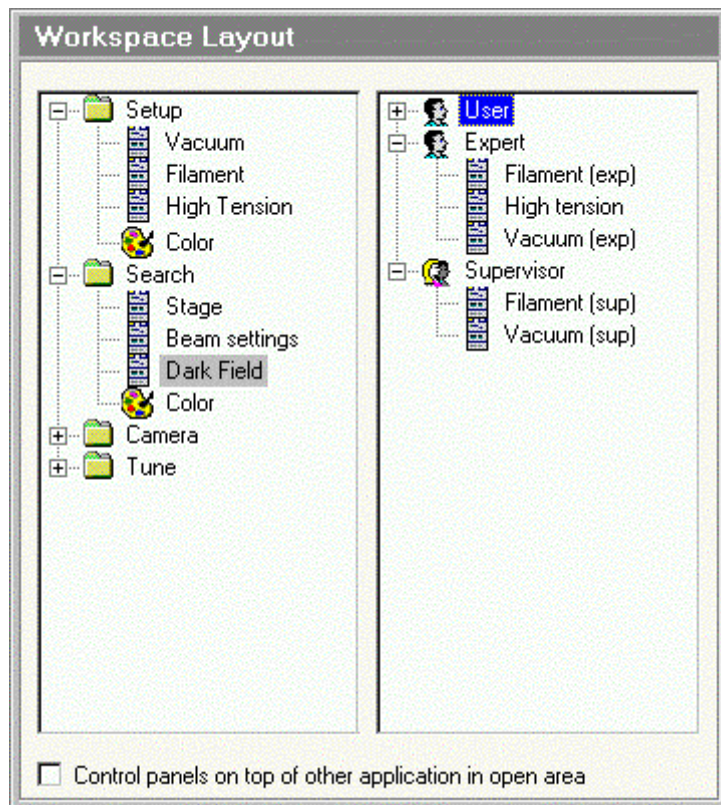

The Workspace Layout Control Panel.

The Workspace Layout Control Panel provides the tools for adjusting the worksets to user preferences.

Worksets

The worksets are represented by folder icons in the left-hand treeview. Clicking on the '+' sign (or double-clicking the folder icon) opens the branch of the workset selected, displaying from - top to bottom - up to three Control panels, the Binding display panel, three status display (Multiselection) panels and Color control.

The following actions are possible on whole worksets:

- **Change the name** : click with the right-hand mouse button on a workset and select Edit label from the popup menu or click on the name and press Enter, type the new text when the label changes to an edit control.
- **Copy a workset** : click with the right-hand mouse button on a workset and select Copy from the popup menu, or press the Ins(ert) key.
- **Delete a workset** : click with the right-hand mouse button on a workset and select Delete from the popup menu, or press the Del(ete) key.
- **Change the sequence of the worksets** : click on a workset and drag it to another position.

To make a new workset, copy an existing workset. Remove any Control panels not needed (Delete), then drag new Control panels from the repository.

Control-panel repository

The treeview on the right-hand side contains a list of all available Control panel (ones that can be inserted into worksets). The panels are separated according to user level (User, Expert, Supervisor) and availability depends on the user levels. Click on the '+' sign or double-click the 'user' icon to expand the particular repository. Control panels can be dragged from the repository into any existing workset.

Control panels

The following actions are possible on Control panels:

- **Delete a panel** : click with the right-hand mouse button on the Control panel and select Delete from the popup menu, or click and then press the Del(ete) key.
- **Change the sequence of panels** : click on a panel and drag it to another position.
- **Move a panel** to another workset by dragging it from one workset into another (drop it on the folder icon).

Binding

The binding display cannot currently be defined in the workspace layout. Click with the right-hand mouse button on the display panel itself to modify settings.

Multiselection

The Multiselection status display cannot currently be defined in the Workspace layout. Click with the right-hand mouse button on a status display panel to modify settings.

Color

When the Color icon of a workset is clicked, the right-hand side of the Workspace layout Control panel changes to the following:

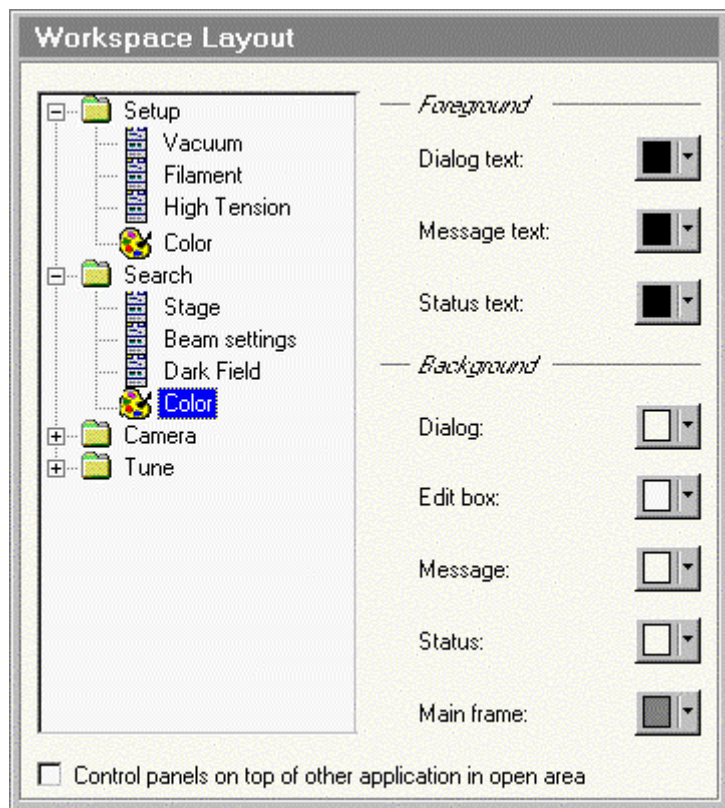

Some of the items listed are standard Windows controls (Dialog, Edit box), other are specific to the Tecnai user interface (Message and Status). Note that Control panels fall under Dialog. The down buttons on the controls on the right-hand side give access to a (standard Windows) 16-color palette from which a color can be selected. An example of a (pretty awful) selection that differs from the default is:

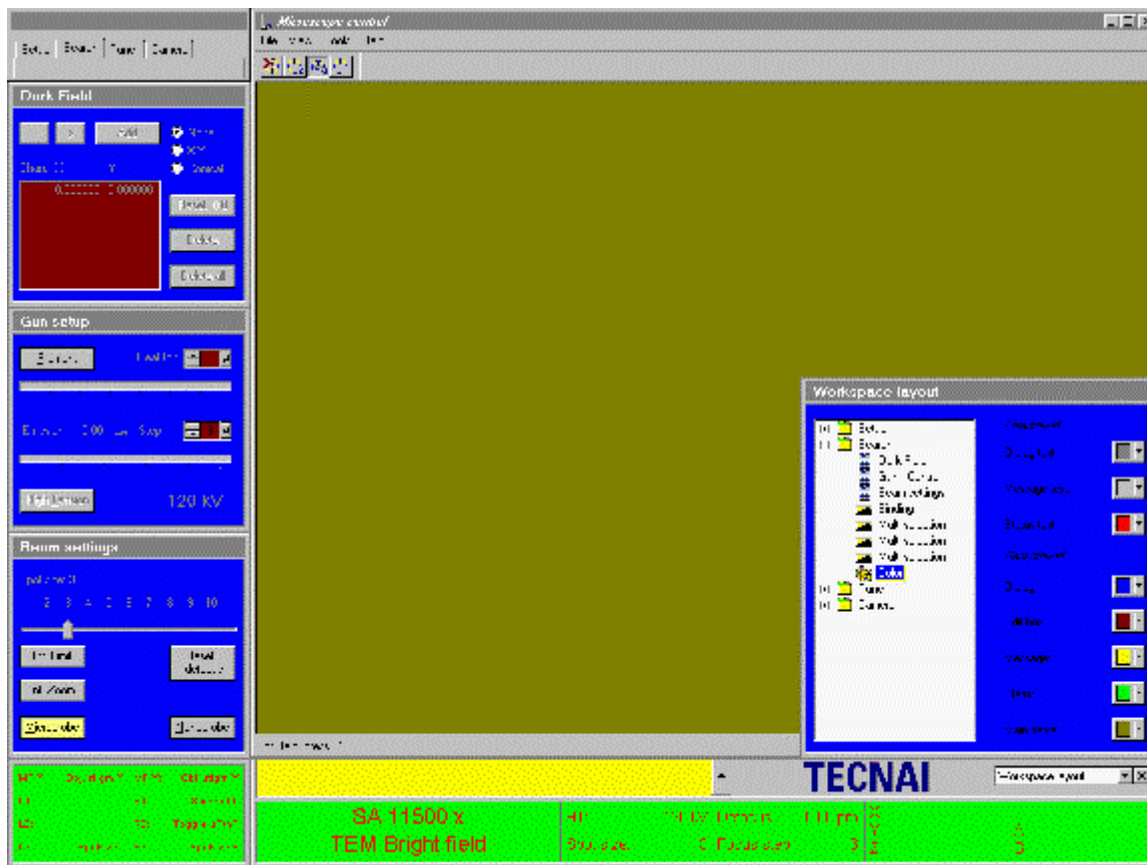

In order to achieve some of these color adjustments the workset temporarily changes the default Windows color selection (if you change the window background - like the olive background in the picture above, other programs will display the same background when the colored workset is active).

Changing colors allows quick adjustment of the amount of light coming from the monitor (without having to fiddle with the monitor controls themselves). It is possible, for example to make a copy of an existing workset and then change the colors in the copy to dark colors for working in dim room lighting while the original could be used for a brighter environment.

Control panels on top of other application in open area

In some cases settings in control panel flap-out must be set but the flap-out disappears behind another application (such as TIA - Tecnai Imaging & Analysis - or DigitalMicrograph). In that case checking Control panels on top of other application in open area will keep the control panel flap-out over the other application. Be aware that this can lead to some bizarre-looking effects due to the limitations of Windows (in positioning windows) and the fact that the on-top effect is applied only to control panels with flap-out. It can also be difficult to get back to the user interface as a whole (to get back, minimize other applications until the whole user interface is displayed). Use the feature when necessary but be aware of its effects.

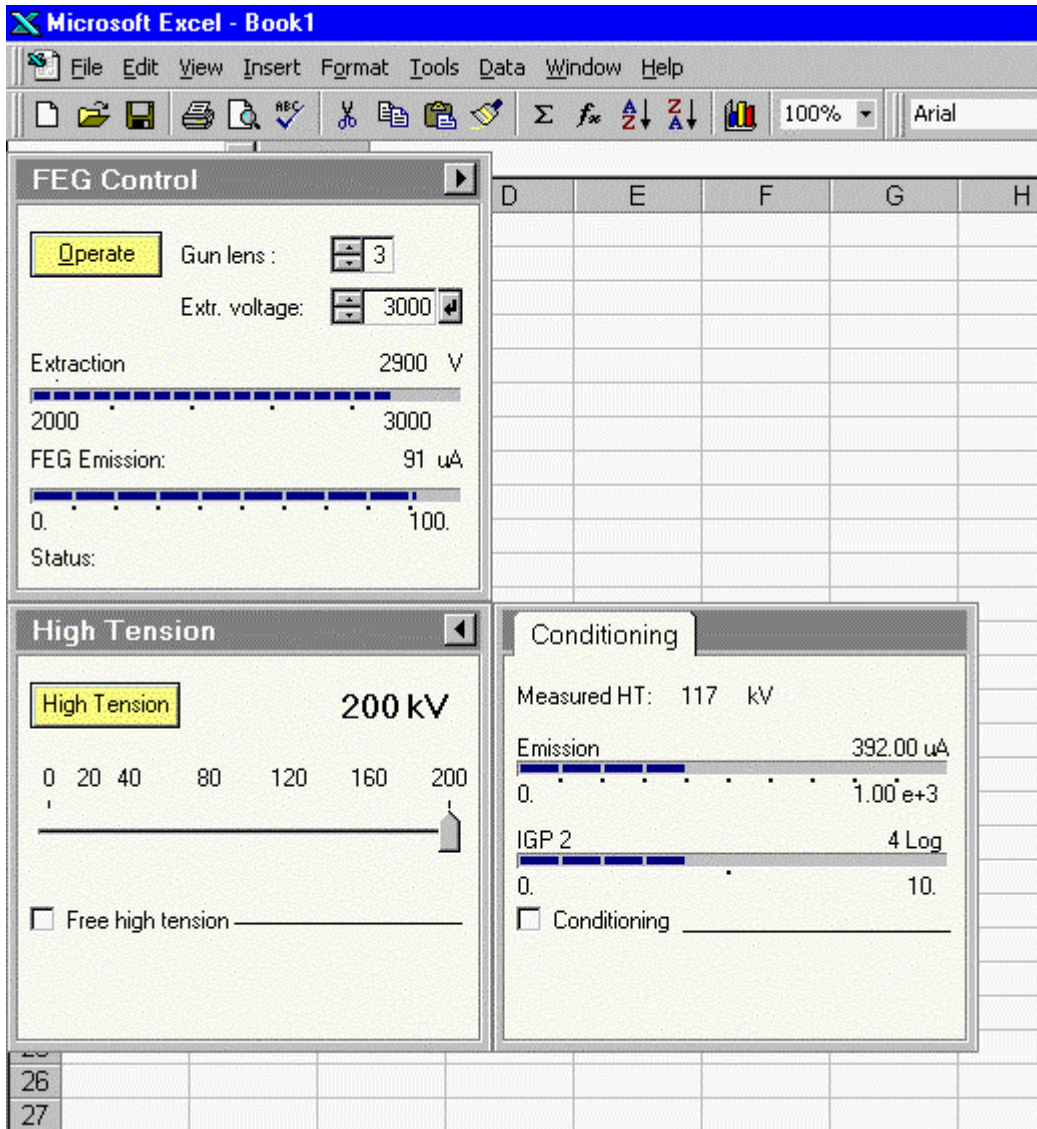

Strange effects can occur when 'on-top' is enabled. Here two Tecnai control panels float over Microsoft Excel seemingly disconnected from the rest of the Tecnai user interface.

5 Control Pads

5.1 Left-hand Control Pad

The left-hand Control Pad (called that way because it will normally be to the left of the microscope column) contains a track ball, a number of buttons and turn (rotary) knobs, and two tilt switch controls. The functions of some of these controls can be reprogrammed by software. In the overview below the 'standard' functionality is therefore indicated.

The left-hand pad has green background lighting available to make it easier to locate the controls when working in the dark.

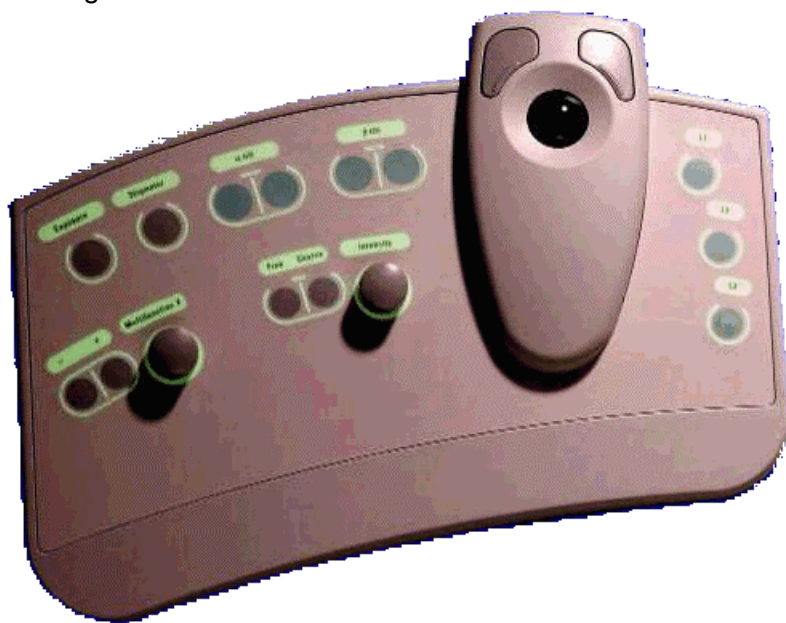

Control	Default function
Exposure	Executes (or interrupts) a TEM exposure
Stigmator	Makes stigmator active or inactive
α tilt	Changes α tilt of stage up or down
β tilt	Changes β tilt (only for double-tilt holders) up or down
Track ball	Beam shift
Multifunction +/-	Changes step size of Multifunction knobs
Multifunction X	Variable
Intensity Fine/Coarse	Switches Intensity between Fine-Medium-Coarse
Intensity	Changes Intensity setting
User button L1	None
User button L2	None
User button L3	Spot size - (to a larger spot size)

Exposure button

The Exposure button starts a TEM exposure on the plate camera. If the viewing screen is down, it will automatically be lifted. The exposure conditions used are those selected previously.

If the Exposure button is pressed again while an exposure is taking place, the exposure is broken off and, if necessary, the plate inserted is removed.

Stigmator button

The Stigmator button activates/deactivates the stigmator functionality of the microscope (access to the setting of the default stigmator under the multifunction knobs). The default stigmator is assigned automatically to the stigmator that is used most often in the current microscope mode (objective stigmator in TEM HM imaging and LAD; diffraction stigmator in HM diffraction and LM imaging, condenser stigmator for nanoprobe and STEM). To switch to a different stigmator, press the corresponding button in the stigmator control panel.

a Tilt Switch

The α tilt switch controls the α tilt of the CompuStage (the axis along the specimen-holder rod that is the eucentric tilt). The tilt switch is pressure sensitive. The α tilt will tilt faster when the switch is pressed harder.

b Tilt Switch

The β tilt controls the β tilt of the CompuStage (the axis perpendicular to the specimen-holder rod that is not eucentric) when a double-tilt holder is used. The tilt switch is pressure sensitive. The β tilt will tilt faster when the switch is pressed harder.

Track ball Left-hand Pad

The left-hand track ball controls the shift of the electron beam. The beam shift operates such that moving the track ball to the right moves the beam as seen on the screen to the right. The speed at which the beam moves is dependent on the magnification and further controlled with the left-hand (speed down) and right-hand (speed up) buttons of the track ball.

Multifunction knobs

The Multifunction knobs have a wide range of functions. All functions (wobbler, stigmators, dark field, alignment, etc.) that assign functionality to the multifunction knobs also release that functionality when the particular function is switched off again (after which the multifunction knobs regain their previous functionality). The functions are typically assigned whenever needed (e.g. during alignment). The user can also assign functions to the knobs (these functions will be overruled when necessary). There are two possibilities:

- The assignment is persistent (these functions will be overruled when necessary but the function is always returned when automatic assignments are taken off).
- The assignment is temporary (these functions will also be overruled when necessary and the function is not returned when automatic assignments are taken off).

A persistent assignment can only be made when the Multifunction knobs are not currently occupied by an automatic assignment, otherwise the assignment is temporary.

Examples

- The Multifunction knobs are currently assigned to the Stage axes (a user assignment). The user clicks with the right-hand mouse on the Binding display panel and chooses another function. This assignment is persistent.
- The Multifunction knobs are currently assigned to the Wobbler (after the Wobbler button has been pressed). The user clicks with the right-hand mouse button on the Binding display panel and chooses another function. This assignment is temporary (comes on top of the automatic Wobbler assignment) and will disappear when the Wobbler is switched off.

The None and Clear functions

The popup menu that allows setting of the binding configuration for the Multifunction knobs can have two functions, None and Clear. None is always enabled, Clear only when the current assignment of the Multifunction knobs is temporary. If None is selected, all functions of the Multifunction knobs are removed, independent of the nature of the current assignment (persistent, temporary or automatic). If

Clear is selected (thus only possible if the assignment is temporary), the Multifunction knobs revert to their prior automatic setting. Thus if you assigned the Beam shift function to the Multifunction knobs in an alignment procedure and then select None, the Multifunction knobs are completely cleared of all functions. Whereas if you used clear, the Multifunction knobs get back their setting from the alignment procedure.

Intensity

The Intensity button controls the intensity on the screen (through focusing or defocusing of the electron beam). The intensity step size is controlled by the fine and coarse buttons directly to the left of the knob (there are three settings: Fine - the Fine LED will be illuminated; Medium - no LED is illuminated; and Coarse - the Coarse LED is illuminated).

Turning Intensity clock-wise is going towards overfocus with the C2 lens.

User buttons Left-hand Pad

The user buttons can be used to program in specific functionality, either by assigning it by right-clicking in the binding display panel and selecting a function or by connecting the user-button input to user programs.

5.2 Right-hand Control Pad

The right-hand Control Pad (called that way because it will normally be to the right of the microscope column) contains a track ball, and a number of buttons and turn (rotary) knobs. The functions of some of these controls can be reprogrammed by software. In the overview below the 'standard' functionality is therefore indicated.

The right-hand pad has green background lighting available to make it easier to locate the controls when working in the dark.



Control	Default function
User button R1	Screen lift
User button R2	Switch microprobe <-> Nanoprobe
User button R3	Spot size + (to a smaller spot size)
Track ball	Stage X,Y
Z-axis	Changes Z position of stage up or down
Eucentric focus	Sets objective lens focus for eucentric height / Diffraction focus
Wobbler	Switches wobbler on or off
Diffraction	Switches between Image and Diffraction
Dark Field	Switches between Dark Field and Bright Field
Focus step	Changes the step size of the Focus control
Focus	Changes the focus
Magnification	Changes magnification or camera length up or down
Multifunction Y	Variable

User buttons Right-hand Pad

The user buttons can be used to program in specific functionality, either by assigning it by right-clicking in the binding display panel and selecting a function or by connecting the user-button input to user programs.

Track ball Right-hand Pad

The right-hand track ball in its default setting controls the X-Y movement of the CompuStage. The functionality is such that moving the track ball to right moves the stage (as seen on the viewing screen) to the right, etc. The axes of the CompuStage usually coincide with the principal directions of the viewing screen (N-S, E-W), somewhat dependent on the nature of the magnification series (some magnifications may not be achievable without rotation relative to the majority of the magnifications). The track ball buttons (top left and top right of the track ball itself) have the following meaning when the track ball is assigned to the CompuStage movement :

- Left-hand button : CompuStage speed value adjusted one step down.
- Right-hand button : CompuStage speed value adjusted one step up.
- Both buttons at the same time : toggle between track ball and 'joy stick' movement modes of the CompuStage.

Note: At the lowermost speed setting the CompuStage will also step by its smallest step, independent of the magnification. At low magnifications these steps may be so small as to be unnoticeable.

Z-axis control

The Z-axis control is a double switch that controls the height of the CompuStage (Z axis). It is used to change the specimen height to make the point of interest coincide with the eucentric height.

Eucentric focus

The Eucentric focus button sets the objective-lens current to the (pre-aligned) value for focus at the eucentric height and normalizes the objective lens. Different microscope modes, like microprobe and nanoprobe, have their own independent settings.

Note: the eucentric focus only sets the objective lens for the eucentric height, not the specimen itself (if the specimen is off the eucentric height, it will then appear out of focus).

The eucentric focus can be used to bring the specimen to the eucentric height easily. Press the eucentric focus to set the objective lens. Switch on the wobbler and focus the specimen by moving the Z height up or down (the wobbler makes it easy to see if the specimen Z height moves in the right direction - the distance between the two wobbler images will become smaller).

Wobbler

The Wobbler button switches the wobbler focusing aid on and off. When the wobbler is on, the LED of the Wobbler button is lit. When the wobbler is on, its (beam-tilt) amplitude can be changed with the Multifunction-Y knob, while the Multifunction-X knob can be used to rotate the direction of the wobbler tilt.

Diffraction button

The Diffraction button switches between image and diffraction modes. When the microscope is in diffraction, the LED of the diffraction button is lit.

Dark-field button

The Dark-field button toggles between dark field and bright field. When dark field is active, the LED of the button is lit.

Focus

The Focus knob is a double control, with Focus and Focus Step integrated. The focusing function is performed by turning the inner, top-most knob. The step size used for focusing depends on the current focus step which is set by the Focus Step control, the outer, lower-lying ring around the Focus knob itself.

Magnification

The magnification knob turns the magnification or camera length on the microscope up (when turned clock-wise) or down.

Multifunction knobs

The Multifunction knobs have a wide range of functions. All functions (wobbler, stigmators, dark field, alignment, etc.) that assign functionality to the multifunction knobs also release that functionality when the particular function is switched off again (after which the multifunction knobs regain their previous functionality). The functions are typically assigned whenever needed (e.g. during alignment). The user can also assign functions to the knobs (these functions will be overruled when necessary). There are two possibilities:

- The assignment is persistent (these functions will be overruled when necessary but the function is always returned when automatic assignments are taken off).
- The assignment is temporary (these functions will also be overruled when necessary and the function is not returned when automatic assignments are taken off).

A persistent assignment can only be made when the Multifunction knobs are not currently occupied by an automatic assignment, otherwise the assignment is temporary.

Examples

The Multifunction knobs are currently assigned to the Stage axes (a user assignment). The user clicks with the right-hand mouse on the Binding display panel and chooses another function. This assignment is persistent.

The Multifunction knobs are currently assigned to the Wobbler (after the Wobbler button has been pressed). The user clicks with the right-hand mouse button on the Binding display panel and chooses another function. This assignment is temporary (comes on top of the automatic Wobbler assignment) and will disappear when the Wobbler is switched off.

The None and Clear functions

The popup menu that allows setting of the binding configuration for the Multifunction knobs can have two functions, None and Clear. None is always enabled, Clear only when the current assignment of the Multifunction knobs is temporary. If None is selected, all functions of the Multifunction knobs are removed, independent of the nature of the current assignment (persistent, temporary or automatic). If

Clear is selected (thus only possible if the assignment is temporary), the Multifunction knobs revert to their prior automatic setting. Thus if you assigned the Beam shift function to the Multifunction knobs in an alignment procedure and then select None, the Multifunction knobs are completely cleared of all functions. Whereas if you used clear, the Multifunction knobs get back their setting from the alignment procedure.